

TECHNICAL MANUAL

**OPERATOR'S, ORGANIZATIONAL,
DIRECT SUPPORT, AND GENERAL SUPPORT
MAINTENANCE MANUAL
(INCLUDING REPAIR PARTS AND SPECIAL TOOLS LIST)**

FOR

**PLUG-IN, LOW FREQUENCY
(SPECTRUM ANALYZER)
PL-1387/U
(HP-8556A)
(NSN 6625-00-167-5267)**

HEADQUARTERS, DEPARTMENT OF THE ARMY

27 APRIL 1983



5

SAFETY STEPS TO FOLLOWING SOMEONE IS THE VICTIM OF ELECTRICAL SHOCK

1

DO NOT TRY TO PULL OR GRAB THE INDIVIDUAL

2

IF POSSIBLE, TURN OFF THE ELECTRICAL POWER

3

IF YOU CANNOT TURN OFF THE ELECTRICAL POWER, PULL, PUSH OR LIFT THE PERSON TO SAFETY USING A DRY WOODEN POLE OR A DRY ROPE OR SOME OTHER INSULATING MATERIAL

4

SEND FOR HELP AS SOON AS POSSIBLE

5

AFTER THE INJURED PERSON IS FREE OF CONTACT WITH THE SOURCE OF ELECTRICAL SHOCK, MOVE THE PERSON A SHORT DISTANCE AWAY AND IMMEDIATELY START ARTIFICIAL RESUSCITATION

WARNINGS

Removing the top cover from the Display Section exposes the operator to dangerous potentials (up to 7000 volts).

INPUT connector ground is isolated from cabinet ground. Any voltage present on cable shield will be present on connector shell (± 100 VDC maximum). If contacted, this voltage may cause personal injury.

SPECTRUM ANALYZER LF SECTION

8556A

Serials Prefixed: 1104A

This manual applies directly to LF Sections with the serial number prefixes listed above.

Serial Prefixes Not Listed

For LF Sections with serial prefixes not listed, a "Manual Changes" insert is included with this manual.

Copyright HEWLETT-PACKARD COMPANY 1971
1501 PAGE MILL ROAD, PALO ALTO, CALIFORNIA, U.S.A.

Manual Part No. 08556-90004
Microfiche Part No. 08556-90006

Printed JULY 1971



CERTIFICATION

Hewlett-Packard Company certifies that this instrument met its published specifications at the time of shipment from the factory. Hewlett-Packard Company further certifies that its calibration measurements are traceable to the United States National Bureau of Standards, to the extent allowed by the Bureau's calibration facility, and to the calibration facilities of other International Standards Organization members.

WARRANTY AND ASSISTANCE

This Hewlett-Packard product is warranted against defects in materials and workmanship for a period of one year from the date of shipment. Hewlett-Packard will, at its option, repair or replace products which prove to be defective during the warranty period provided they are returned to Hewlett-Packard, and provided the preventive maintenance procedures in this manual are followed. Repairs necessitated by misuse of the product are not covered by this warranty. NO OTHER WARRANTIES ARE EXPRESSED OR IMPLIED, INCLUDING, BUT NOT LIMITED TO, THE IMPLIED WARRANTIES OF MERCHANTABILITY AND FITNESS FOR A PARTICULAR PURPOSE. HEWLETT-PACKARD IS NOT LIABLE FOR CONSEQUENTIAL DAMAGES.

If this product is sold as part of a Hewlett-Packard integrated instrument system, the above warranty shall not be applicable, and this product shall be covered only by the system warranty.

TECHNICAL MANUAL }
No. 11-6625-2781-14 & P-5 }

HEADQUARTERS
DEPARTMENT OF THE ARMY
Washington, DC, 27 April 1983

**OPERATOR'S, ORGANIZATIONAL, DIRECT SUPPORT,
AND GENERAL SUPPORT MAINTENANCE MANUAL,
INCLUDING REPAIR PARTS AND SPECIAL TOOLS LISTS
FOR
PLUG-IN, LOW FREQUENCY
(SPECTRUM ANALYZER)
PL-13871U
(HP-8556A)
(NSN 6625-00-167-5267)**

REPORTING ERRORS AND RECOMMENDING IMPROVEMENTS

You can improve this manual. If you find any mistakes, or if you know of a way to improve the procedures, please let us know. Mail your letter or DA Form 2028 (Recommended Changes to Publications and Blank Forms) directly to: Commander, US Army Communications-Electronics Command and Fort Monmouth, ATTN: DRSEL-ME-MP, Fort Monmouth, NJ 07703. In either case a reply will be furnished directly to you.

TABLE OF CONTENTS

SECTION O	INTRODUCTION	Page
O-1	Scope	O-1
O-2	Index of Publications	O-1
O-3	Maintenance Forms, Records, and Reports	O-1
O-4	Reporting Equipment Improvement Recommendations (EIR)	O-1
O-5	Administrative Storage	O-1
O-6	Destruction of Army Electronic Materiel	O-1

TABLE OF CONTENTS

Section	Page	Section	Page
I GENERAL INFORMATION	1-1	V ADJUSTMENTS	5-1
1-1. Introduction	1-1	5-1. Introduction	5-1
1-5. Instruments Covered by Manual	1-1	5-4. Test Equipment Required	5-1
1-7. Description	1-1	5-7. Posidriv Screwdrivers	5-1
1-15. Accessories Supplied	1-2	5-9. Blade Tuning Tools	5-1
1-18. Equipment Required but not Supplied.....	1-2	5-11. HP 11592A Service Kit	5-1
1-20. IF Sections	1-2	5-14. Extender Cable Installation	5-1
1-22. Display Sections	1-2	5-18. Factory Selected Components	5-1
1-24. Compatibility.....	1-2	5-20. Related Adjustments	5-1
1-27. Operating Accessories	1-2	5-23. Voltage Checks	5-2
1-29. Test Equipment Required.....	1-2	5-24. Pre-Attenuator Adjustments:	
1-31. Warranty.....	1-2	COMP and C IN	5-4
II INSTALLATION	2-1	5-25. 50.150 MHz Local Oscillator	
2-1. Initial Inspection.....	2-1	Adjustment: A6T1	5-6
2-2. Mechanical Check.....	2-1	5-26. Mixer Balance Adjustments: C, R and Z.....	5-7
2-4. Electrical Check.....	2-1	5-27. Tracking Generator Adjustments:	
2-6. DELETED	2-1	AMPL ADJ and FLATNESS ADJ.....	5-8
2-9. Preparation for Use	2-1	5-28. Frequency Calibration Adjustment:	
2-10. Shipping Configuration	2-1	OFFSET ADJ, 300 kHz ADJ, and	
2-12. Power Requirements	2-1	ZERO ADJ	5-10
2-15. Power Cable	2-1	5-30. 8552A 47 MHz LO Adjustment	5-13
2-17. Operating Environment.....	2-1	VI REPLACEABLE PARTS.....	6-1
2-19. Interconnections	2-1	6-1. Introduction	6-1
2-22. Storage and Shipment	2-2	6-5. DELETED	6-1
2-23. Original Packaging.....	2-2	VII MANUAL CHANGES	
2-27. Other Packaging Materials	2-2		DELETED
III OPERATION	3-1	VIII SERVICE	8-1
3-1. Introduction	3-1	8-1. Introduction	8-1
3-3. Panel Features	3-1	8-3. Theory of Operation.....	8-1
3-5. Operator's Checks	3-1	8-5. Recommended Test Equipment	8-1
3-7. Operating Considerations	3-1	8-8. Troubleshooting	8-1
3-9. RF Input.....	3-1	8-13. General Service Information	8-1
3-12. Amplitude Ranges	3-1	8-14. Part Location Aids.....	8-1
3-16. First Mixer Balance	3-1	8-16. Factory Selected Components	8-1
3-23. Operating Instructions	3-2	8-18. Diagram Notes	8-1
3-26. Setting the Frequency Scan	3-2	8-20. Servicing Aids on Printed Circuit	
3-31. Adjusting the Amplitude Scale.....	3-2	Boards	8-2
3-37. Using the Tracking Generator.....	3-8	8-22. Circuit Board Extender	8-2
3-52. Variable Persistence and Storage		8-24. General Service Hints	8-2
Functions.....	3-10	8-25. Etched Circuits	8-2
3-57. Photographic Techniques	3-10	8-27. Etched Conductor Repair	8-2
IV PERFORMANCE TESTS		8-29. Component Replacement	8-2
4-1. Introduction	4-1	8-36. Logic Circuits and Symbols	8-5
4-4. Equipment Required	4-1	8-40. Basic AND Gate (Positive Logic).....	8-6
4-6. Operational Adjustments	4-1	8-42. Basic OR Gate (Positive Logic)	8-6
4-8. Front Panel Checks	4-1	8-45. Truth Tables.....	8-6
4-10. Test Sequence	4-1	8-47. Logic Inversion	8-6
4-14. Tracking Generator Amplitude.....	4-3	8-49. Binary Circuits and Symbols	8-6
4-15. Marker Accuracy	4-4	8-51. Reset-Set (RS) Flip-Flop.....	8-6
4-16. Scan Width Accuracy.....	4-6	8-53. The RST Flip-Flop.....	8-8
4-17. Center Frequency Accuracy.....	4-7	8-55. Clocked JK Flip-Flop	8-8
4-18. Frequency Response	4-8	8-57. JK Master/Slave Flip-Flop	8-9
4-19. Average Noise Level	4-10	8-60. Preset and Clear	8-10
4-20. Residual Responses	4-12	8-62. Operational Amplifiers	8-10
4-21. Spurious Responses	4-14	8-63. Circuits and Symbols	8-10
4-22. Residual FM.....	4-17	8-66. Troubleshooting	8-12
4-23. Noise Sidebands	4-19	8-70. Dial Calibration Procedure.....	8-12
4-24. Input Level Control and Gain Compression.....	4-21		
4-25. Tracking Generator Spectral Purity	4-23		

LIST OF ILLUSTRATIONS

Figure	Page	Figure	Page
1-1	Model 8556A Spectrum Analyzer LF Section with 8552B IF Section and 141T Display Section ...	8-17	LF Section Block Diagram
	1-0	8-18	8-27
1-2	Instrument Identification	8-19	} Reserved for Optional Inputs (will not appear in this printing).
1-3	Typical Spectrum Analyzer Resolution.....	8-20	
1-4	Typical Spectrum Analyzer Distortion Products.....	8-21	
1-5	HP 11592A Service Kit		Master Board Assembly A11 Component Locations
2-1	LF Section and IF Section Interconnections	8-22	Pre-Attenuator and Preamplifier Assembly A5 Component Locations
3-1	Front Panel Features	8-23	Pre-Attenuator and Preamplifier: A3, A5 and All Schematic.....
3-2	Operational Adjustments	8-24	Input Level Switch Assembly A3 Component Locations
3-3	Typical Frequency Response Measurement (in 50 Ohms)	8-25	Frequency Converter Assembly A6 Component Locations
3-4	Typical Amplifier Frequency Response Meas- urement (in 600 Ohms) using a Frequency Counter.....	8-26	Post-Attenuator and Frequency Converter: A3 and A6 Schematic.....
	3-9	8-27	Tracking Generator Frequency Converter Assembly A9 Component Locations
4-1	Tracking Generator Test Setup	8-28	Tracking Generator Frequency Converter: A9 Schematic.....
4-2	Marker Accuracy Test Setup.....	8-29	Tracking Generator Output Assembly A8 Component Locations
4-3	Scan Width Accuracy Display	8-30	3 MHz Oscillator Assembly A8A1 Component Locations
4-4	Frequency Response Test Setup	8-31	Input Level Switch Assembly A3 Component Locations
4-5	Average Noise Level Display	8-32	Tracking Generator Output: A3 and A8 Schematic.....
4-6	Residual Responses Display.....	8-33	Integrated Circuit Logic Diagrams
4-7	Spurious Responses Test Setup	8-34	Frequency Control and Marker Generator Assembly A7 Component Locations
4-8	Intermodulation Distortion Products Display.....	8-35	20 kHz Marker Circuits: A7 Schematic.....
4-9	Residual FM Test Setup.....	8-36	Scan Width Switch Assembly A2 Component Locations
4-10	Residual FM Display.....	8-37	Frequency Control and Marker Generator Assembly A7 Component Locations
4-11	Noise Sidebands Test Setup.....	8-38	Frequency Control Circuits: A1, A2 and A7 Schematic
4-12	Noise Sidebands Display	8-39	Simplified Analogic Diagram
4-13	Input Level Control and Gain Compression Test Setup.....	8-40	Bandwidth Switch Assembly A1 Component Locations
	4-21	8-41	Scan Width Switch Assembly A2 Component Locations
4-14	Tracking Generator Spectral Purity Test Setup	8-42	Analogic Circuits: A1 and A2 Schematic
5-1	Voltage Checks Test Setup.....	8-43	Bandwidth Switch Assembly A1 Component Locations
5-2	Pre-Attenuator Adjustment Test Setup.....	8-44	Input Level Switch Assembly A3 Component Locations
5-3	50.150 MHz Local Oscillator Adjustment Test Setup	8-45	IF Section Control Circuits: A1 and A3 Schematic.....
	5-6	8-46	Power Supply Assembly A10 Component Locations
5-4	Mixer Balance Adjustments Test Setup	8-47	Master Board Assembly A11 Component Locations
5-5	Tracking Generator Adjustment Test Setup	8-48	Power Supply and Voltage Distribution: A10 and All Schematic.....
5-6	Frequency Calibration Adjustment Test Setup		8-63
5-7	47 MHz LO Adjustment Display		8-59
6-1	Front Panel Parts, Exploded View.....		
8-1	8556A LF Section with Circuit Board Extended		
8-2	Examples of Diode and Transistor Marking Methods		
	8-4		
8-3	Integrated Circuit Packaging		
	8-5		
8-4	Basic AND and OR Gates		
	8-5		
8-5	Basic NAND and NOR Gates		
	8-6		
8-6	Logic Comparison Diagrams		
	8-7		
8-7	RS Flip-Flop.....		
	8-7		
8-8	RST Flip-Flop		
	8-8		
8-9	The Clocked JK Flip-Flop		
	8-9		
8-10	JK Master/Slave Flip-Flop		
	8-10		
8-11	Operational Amplifier Equivalent Circuit.....		
	8-11		
8-12	Dial Restraining Procedure.....		
	8-13		
8-13	Overall Troubleshooting Tree		
	8-15		
8-14	Top and Bottom Internal Views		
	8-19		
8-15	Troubleshooting Block Diagram		
	8-23		
8-16	Simplified Analyzer Block Diagram		
	8-27		

LIST OF TABLES

Table	Page	Table	Page
1-1	Specifications	1-3	
1-2	Supplemental Performance Characteristics	1-6	
1-3	Operating Accessories	1-9	
1-4	Test Equipment	1-9	
1-5	Test Equipment Accessories	1-11	
4-1	Front Panel Checks	4-2	
4-2	Performance Test Record.....	4-25	
5-1	Analogic Display Calibration Check.....	5-12	
5-2	Check and Adjustment Test Record.....	5-15	
6-1		Designators and Abbreviations used in Parts List.....	6-1
6-2		Manufacturers Code List.....	6-2
6-3		Replaceable Parts	6-3
8-1		Factory Selected Components	8-2
8-2		Etched Circuit Soldering Equipment.....	8-4
8-3		Schematic Diagram Notes	8-14
8-4		Assembly and Component Locations	8-19
8-5		Connector P2 Pin Identification	8-21
8-6		Connector P3 Pin Identification	8-21
8-7		Connector XA11 Pin Identification	8-21

APPENDIXES

		Page
APPENDIX	A. REFERENCES	A-1
APPENDIX	B. MAINTENANCE ALLOCATION	
Section	I. Introduction	B-1
	II. Maintenance Allocation Chart	B-3
	III. Tool and Test Equipment Requirements	B-4
APPENDIX	C. COMPONENTS OF END ITEM LIST (Not applicable)	
APPENDIX	D. ADDITIONAL AUTHORIZATION LIST (Not applicable)	
APPENDIX	E. EXPENDABLE SUPPLIES AND MATERIALS (Not applicable)	
APPENDIX	F. PART NUMBER-NATIONAL STOCK NUMBER INDEX	F-1
APPENDIX	G. MANUFACTURER'S ERRATA AND MANUAL CHANGES	G-1

SECTION O

INTRODUCTION

O-1. Scope

This manual provides technical data, and installation, operation, and maintenance instructions for the spectrum analyzer low-frequency plug-in PL1387/U, Hewlett-Packard model 8556A. The PL1387/U is referred to throughout this manual as the 8556A. Appendix A lists pertinent publications. Appendix B contains the Maintenance Allocation Chart (MAC), which defines the levels and scope of maintenance functions for the equipment in the Army system, and a list of the tools and test equipment required. Appendix F provides a cross reference between commercial part numbers and National Stock Numbers (NSN). Appendix G provides a listing of errors in this manual, and changes which are to be made to the manual, depending on the serial number of the 8556A with which the manual is to be used. As indicated, for plug-ins having serial numbers from 1124A00121, to 1124A00130, only change 1 is to be applied to the manual. For plug-ins with serial numbers 1404A2236 and later models, all nine changes to the manual are required. The list of appendices is located on page iv, following LIST OF TABLES in TABLE OF CONTENTS.

O-2. Consolidated Index of Army Publications and Blank Forms

Refer to the latest issue of DA PAM 310-1 to determine whether there are new editions, changes or additional publications pertaining to the equipment.

O-3. Maintenance Forms, Records, and Reports

a. Reports of Maintenance and Unsatisfactory Equipment. Department of the Army forms and procedures used for equipment maintenance will be those prescribed by TM 38-750, The Army Maintenance Management system.

b. Report of Packaging and Handling Deficiencies. Fill out and forward SF 364 (Report of Discrepancy (ROD)) as prescribed in AR 735-11-2/ DLAR 4140.55/NAVMATINST 4355.73/AFR 400-54/MCO 4430.3E.

c. Discrepancy in Shipment Report (DISREP) (SF 361). Fill out and forward Discrepancy in Shipment Report (DISREP) (SF 361) as prescribed in AR 55-38 NAVSUPINST 4610.33B AFR 75-18./MCO P 4610.19C/DLAR 4500.15.

O-4. Reporting Equipment Improvement Recommendations (EIR)

If your plug in 8556A needs improvement, let us know. Send us an EIR. You, the user, are the only one who can tell us what you don't like about your equipment. Let us know why you don't like the design. Put it on an SF 368 (Quality Deficiency Report). Mail it to: Commander, US Army Communications-Electronics Command and Fort Monmouth, ATTN; DRSEL-ME-MP, Fort Monmouth, NJ 07703. We'll send you a reply.

O-5. Administrative Storage

The 8556A plug-in can be stored in stockrooms, warehouses, or other protected facilities. The equipment should be protected from excessive humidity, sand, dust, and chemical contaminants. Before putting the 8556A in administrative storage, make the following preparations:

a. Complete the operational adjustments procedure given in figure 3-2 to assure that the plug-in is operable.

b. If the original packing material is not available, at least protect the unit with protective plastic or paper wrapping. Place the unit in a carton or box with makeshift protective packing material around it.

c. Store the equipment indoors, protected from the elements. Maintain the equipment at moderate temperature and humidity.

O-6. Destruction of Army Electronic Materiel

Destruction of Army electronic materiel to prevent enemy use shall be in accordance with TM 750-244-2.

MODEL 8556A

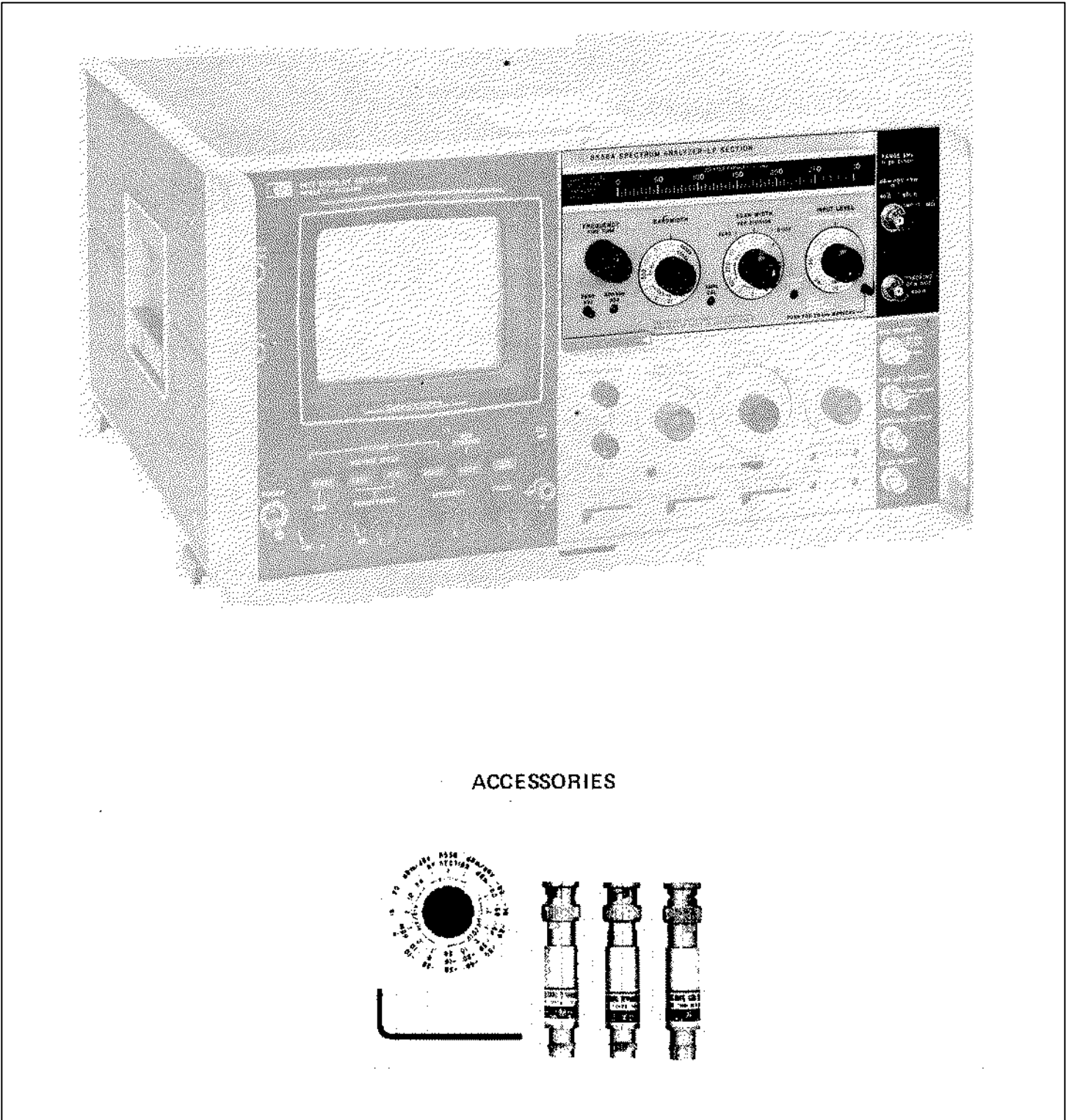

Figure 1-1. Model 8556A Spectrum Analyzer LF Section with 8552B IF Section and 141T Display Section

SECTION I

GENERAL INFORMATION

1-1. INTRODUCTION

1-2. This manual contains all information required to install, operate, test, adjust and service the Hewlett-Packard Model 8556A Spectrum Analyzer LF Section. This section covers instrument identification, description, options, accessories, specifications and other basic information.

1-3. Figure 1-1 shows the Hewlett-Packard Model 8556A Spectrum Analyzer LF Section with the Model 8552B Spectrum Analyzer IF Section and the Model 141T Display Section. Also shown are the accessories supplied with the 8556A (see paragraph 1-15).

1-4. The various sections in this manual provide information as follows:

SECTION II, INSTALLATION, provides information relative to incoming inspection, power requirements, mounting, packing, shipping, etc.

SECTION III, OPERATION, provides information relative to operating the instrument.

SECTION IV, PERFORMANCE TESTS, provides information required to ascertain that the instrument is performing in accordance with published specifications.

SECTION V, ADJUSTMENTS, provides information required to properly adjust and align the instrument after repairs are made.

SECTION VI, REPLACEABLE PARTS, provides ordering information for all replaceable parts and assemblies.

SECTION VII, MANUAL CHANGES, normally will contain no relevant information in the original issue of a manual. This section is reserved to provide back-dating and up-dating information in manual revisions or reprints.

SECTION VIII, SERVICE, includes all information required to repair the instrument.

1-5. INSTRUMENTS COVERED BY MANUAL

1-6. Hewlett-Packard instruments carry a serial number (see Figure 1-2) on the back panel. When the serial

number prefix on the instrument serial number plate of your instrument is the same as one of the prefix numbers on the inside title page of this manual, the manual applies directly to the instrument. When the instrument serial number prefix is not listed on the inside title page of this manual, manual change sheets and manual updating information is provided. Later editions or revisions to the manual will contain the required change information in Section VII.

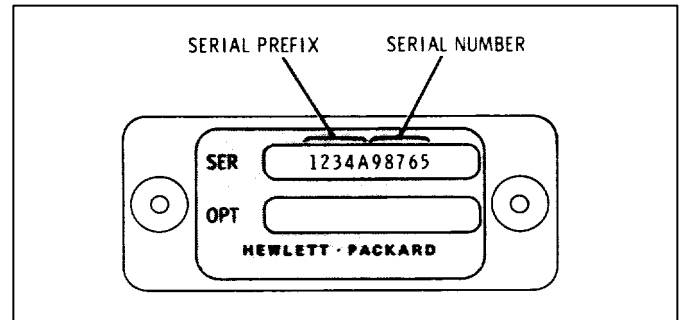

Figure 1-2. Instrument Identification

1-7. DESCRIPTION

1-8. The Hewlett-Packard Model 8556A Spectrum Analyzer LF Section covers the frequency range from 20 Hz to 300 kHz. When it is combined with an IF Section and a Display Section it functions as the tuning section of a low frequency spectrum analyzer.

1-9. The analyzer electronically scans input signals and displays their frequency and amplitude on a CRT. The horizontal, x-axis, is calibrated in units of frequency and the vertical, y-axis, is calibrated in absolute units of voltage (pV, mV, dBV) or power (dBm). Therefore, absolute and relative measurements of both amplitude and frequency can be made.

1-10. The horizontal (frequency) axis can be swept three different ways:

- a. The center of the CRT is set to a frequency determined by the dial and the analyzer is swept symmetrically about that frequency.
- b. The analyzer is not swept but is used as a fixed frequency receiver. Signal amplitude can be read on the CRT and signal modulation can be viewed as with an oscilloscope.

c. The analyzer is swept from 0 Hz to a higher frequency selectable from 200 Hz to 200 kHz.

1-11. The vertical (amplitude) axis provides relative and absolute measurement capability in volts, dBV, dBm into 600 ohms unbalanced, and dBm into 50 ohms.

1-12. The LF Section's input is isolated from the instrument chassis so that the CRT display is free of line frequency spurious responses due to ground loops.

1-13. Accurate frequency calibration is provided by selecting 20 kHz markers.

1-14. The LF Section also contains a tracking generator that produces a calibrated signal that precisely tracks the analyzer tuning frequency. This signal can be used to test the frequency response of a device; it can also be used, with a frequency counter, for making frequency measurements that are accurate to 1 Hz (see Section III).

1-15. ACCESSORIES SUPPLIED

1-16. The 8556A LF Section requires a special knob on the IF Section in place of the standard LOG REF LEVEL control. The special knob has three scales: one is used for the LF Section log calibration (red scale), one for log calibration with the RF Sections (black scale), and one for linear calibration with all units (blue scale). This knob and an allen wrench to install it are supplied with each 8556A. Extra knobs (HP 08556-00013) are available.

1-17. The 8556A is supplied with the following accessories: HP 11095A 600 ohm Feed Thru Termination
HP 11048C 50 ohm Feed Thru Termination
HP 11660A Tracking Generator Shunt (50 ohm output)

1-18. EQUIPMENT REQUIRED BUT NOT SUPPLIED

1-19. The 8556A LF Section must be mated with an IF Section, such as the 8552A or the 8552B, and a Display Section, such as the 140T or the 141T, before the units can perform as a spectrum analyzer.

1-20. IF Sections

1-21. The 8552A IF Section features calibrated bandwidths, log and linear amplitude calibration, and calibrated scan times. The 8552B IF Section has all of the features of the 8552A and, in addition, manual scan,

greater frequency stability, narrower bandwidths and an expanded log scale (2 dB per division).

1-22. Display Sections

1-23. The 140T Display Section is equipped with a fixed persistence, non-storage CRT; the 141T Display Section is equipped with a variable persistence, storage CRT. The 143S Display Section has a large screen (8x10 inch) CRT.

1-24. COMPATIBILITY

1-25. The 8556A LF Section is fully compatible with all current 8552A/B IF Sections; 8552A's with serial prefix 991 and below, and 8552B's with serial prefix 977 and below must be modified. The modification consists of adding a white-blue-grey (24 AWG) wire between 8552A/B connectors XA8 pin 8 and J3 pin 40. (See appropriate 8552 manual for location of connectors.)

NOTE

The 8556A requires a special knob on the IF Section in place of the standard LOG REF LEVEL control (see EQUIPMENT SUPPLIED).

1-26. The 8556A LF Section is fully compatible with all HP 140S/T, HP 141S/T, and HP 143S Display Sections. The 8556A can be used with HP 140A/B and 141A/B Oscilloscope Mainframes but some performance specifications will be slightly degraded. (For more information, contact your nearest Hewlett-Packard office.)

1-27. OPERATING ACCESSORIES

1-28. Operating accessories for use with the 8556A]8552/140 Spectrum Analyzer are listed in Table 1-3. They include a frequency counter, an oscilloscope camera, and various attenuators and probes.

1-29. TEST EQUIPMENT REQUIRED

1-30. Tables 1-4 and 1-5 list the test equipment and test equipment accessories required to check, adjust and repair the 8556A LF Section.

1-31. WARRANTY

1-32. The 8556A LF Section is warranted and certified as indicated on page C.

Table 1-1. Specifications

8556A/8552B/8552A

FREQUENCY

Range:

20 Hz to 300 kHz - 8552B IF Section
 100 Hz to 300 kHz - 8552A IF Section

Tuning Dial Ranges of 0-30 kHz and 0-300 kHz.

Scan Width: (On a 10 div. CRT horizontal axis.)

Per Division: 10 calibrated scan widths from 20 Hz/div to 20 kHz/div in a 1, 2, 5 sequence.

0-10f: 10 calibrated preset scans, from 200 Hz to 200 kHz in a 1, 2, 5 sequence. Analyzer scans from zero frequency to ten times the scan width per division setting.

Zero: Analyzer is a fixed tuned receiver.

Accuracy:

Center Frequency: After 1 hour warmup, zero and 300 kHz adjustments, and with the Fine Tune centered, the dial indicates the display center frequency within the following specifications:

With 8552B IF Section:
 0-30 kHz Range: ± 500 Hz
 0-300 kHz Range: ± 3 kHz

With 8552A IF Section:
 0-30 kHz Range: ± 1 kHz
 0-300 kHz Range: ± 5 kHz

Marker: RF markers every 20 kHz accurate to within $\pm 0.01\%$. Markers controlled by front panel on/off switch.

Scan Width:

With 8552B IF Section:
 Frequency error between any two points on the display is less than $\pm 3\%$ of the indicated frequency separation.

With 8552A IF Section:
 Frequency error between any two points on the display is less than $\pm 5\%$ of the indicated frequency separation.

Stability:

Residual FM:

With 8552B IF Section:
 Sidebands >60 dB down 50 Hz or more from CW signal, scan time ≥ 1 sec/div, 10 Hz band width.

With 8552A IF Section:
 Less than 20 Hz peak-to-peak.

Noise Sidebands: More than 90 dB below CW signal, 3 kHz away from signal, with a 100 Hz IF bandwidth.

Frequency Drift: (After 1 hour warmup.)

With 8552B IF Section: Less than 200 Hz/10 min.

With 8552A IF Section: Less than 1 kHz /10 min.

Resolution:

Bandwidth Ranges: IF bandwidths of 10 Hz (50 Hz for 8552A) to 10 kHz are provided in a 1, 3, 10 sequence.

Bandwidth Accuracy: Individual IF bandwidth 3 dB points calibrated to $\pm 20\%$ (10 kHz band width $\pm 5\%$).

Bandwidth Selectivity: 60 dB/3 dB IF bandwidth ratios.

With 8552B IF Section: $<11:1$ for IF bandwidths from 30 Hz to 3 kHz; $<20:1$ for 10 kHz IF bandwidth. For 10 Hz bandwidth, 60 dB points are separated by less than 100 Hz.

With 8552A IF Section: $<25:1$ for IF bandwidths from 50 Hz to 300 Hz; $<20:1$ for IF bandwidths from 1 kHz to 10 kHz.

Table 1-1. Specifications (cont'd)

AMPLITUDE

Absolute Amplitude Calibration Range:

Log Modes:

dBV	0 dBV = 1 V rms
dBm-600Ω	0 dBm = 1 mW - 600Ω
dBm-502Ω	0 dBm = 1 mW - 502Ω

Input impedance is 1 MΩ. dBm ranges are referenced with input properly terminated externally.

Log Range: From -150 dBm/dBV to +10 dBm/dBV in 10 dB steps. Log reference level vernier, 0 to -12 dB continuously.

Log Display Range: 10 dB/div on a 70 dB display, or 2 dB/div on a 16 dB display (with 8552B only).

Linear Sensitivity: From 0.1 μV/div to 1V/div in a 1, 2, 10 sequence. Linear sensitivity vernier X1 to X0.25 continuously.

Dynamic Range:

Average Noise Level: Specified with a 600Ω or less source impedance and INPUT LEVEL at -60 dBm/dBV.

Mode	1 kHz IF Bandwidth	10 Hz IF Bandwidth
dBm-50 Ω	<-122 dBm (180 nV)	<-142 dBm (18 nV)
dBm-600Ω	<-130 dBm (250 nV)	<-150 dBm (25 nV)
dBV	<-132 dBV (250 nV)	<-152 dBV (25 nV)
Linear	<400 nV	<40 nV

Spurious Responses: Input signal level ≤ INPUT LEVEL
Setting: out of band mixing responses,

TRACKING GENERATOR

Frequency Range: Tracks the analyzer tuning, 20 Hz to 300 kHz.

Amplitude Range: Continuously variable from 100 mV rms to greater than 3V rms into an open circuit.

Amplitude Accuracy: With TRACKING GEN LEVEL in CAL position, output level at 100 kHz is 100 mV ±0.3 dB into an open circuit.

Frequency Response: ±0.25 dB 50 Hz to 300 kHz.

harmonic and intermodulation distortion products are all more than 70 dB below the input signal level 5 kHz to 300 kHz; 60 dB 20 Hz to 5 kHz. Third order intermodulation products are more than 70 dB below the input signal level, 5 kHz to 300 kHz with signal separation >300 Hz.

Residual Responses: (no signal present at input): with the INPUT LEVEL at -60 dBm/dBV and the input terminated with 600Ω or less, all line related residual responses from 0-500 Hz are below -120 dBm/dBV. All other residual responses are below -130 dBm/dBV.

Gain Compression: For input signal level 20 dB above INPUT LEVEL setting gain compression is less than 1 dB.

INPUT LEVEL Control: -10 to -60 dBm/dBV in 10 dB steps. Accuracy ±0.2 dB. Marking indicates maximum input levels for 70 dB spurious-free dynamic range.

Accuracy:

	Log	Linear
Frequency Response: Switching Between Bandwidths (at 20°C),		
100 Hz to 10 kHz:	±0.2 dB	±2.3%
30 Hz to 10 kHz:	±0.5 dB	±5.8%
10 Hz to 10 kHz:	±1.0 dB	+12%
	±1.5 dB	±20%
Display:	±.25 dB/dB but not more than ±1.5 dB over 70 dB display range	±2.8% of full 8 div display

Output Impedance: 600Ω.

Spectral Purity:

Residual FM:
With 8552B IF Section: <1 Hz peak-to-peak.
With 8552A IF Section: <20 Hz peak-to-peak.

Harmonic Signals: >40 dB down.

Spurious Outputs: >50 dB down.

Table 1-1. Specifications (cont'd)

INPUT

Input Impedance: 1 M Ω shunted by \approx 32 pF.

Maximum Voltage. Isolated Ground to Chassis Ground: \pm 100 Vdc.

Maximum Input Level: 10V rms, \pm 200 Vdc.

Ground terminals of BNC input connectors are isolated from the analyzer chassis ground to minimize ground loop pickup at low frequencies.

Isolated Ground to Chassis Ground Impedance: 100 k Ω shunted by approximately 0.3 μ f.

GENERAL

Scan Time: 16 internal scan rates from 0.1 ms/div to 10 sec/div in a 1, 2,5 sequence.

Weight:

Model 8556A LF Section: Net. 8 lb (3,7 kg).

Model 8552B IF Section: Net. 9 lb (4,1 kg).

Model 8552A IF Section: Net. 9 lb (4,1 kg).

Model 140T Normal Persistence Display Section: Net 37 lb (16,8 kg).

Model 141T Variable Persistence Display Section: Net, 40 lb (18 kg).

Model 143S Large Screen Display Section: Net 62 lb (28,1 kg).

Scan Time Accuracy:

0.1 ms/div to 20 ms/div: \pm 10%

50 ms/div to 10 sec/div: \pm 20%.

Power Requirements: 115 or 230 volts \pm 10%, 50 to 60 Hz, less than 225 watts.

Dimensions:

Model 140T or 141T Display Section: 9-1/5" high (including height of feet) x 16-3/4" wide x 18-3/8" deep (229 x 425 x 467 mm).

Model 143S Display Section: 21" high (including height of feet) x 16-3/4" wide x 18-3/8" deep (533 x 425 x 467 mm).

Accessories Included:

Model 11660A Tracking Generator Shunt

Model 11048B 50 Ω Feed Thru Termination

Model 11095A 600 Ω Feed Thru Termination

Table 1-2. Supplemental Performance Characteristics

FREQUENCY CHARACTERISTICS

Range: With 300 kHz Center Frequency and 20 kHz/div Scan Width, analyzer will scan linearly to 400 kHz.

Center Frequency Control: Approximately 10 turns to cover full dial indicator in both 0-30 kHz and 0-300 kHz ranges.

Fine Tune: Single turn control, ± 50 Hz on 0-30 kHz range, ± 500 Hz on 0-300 kHz range.

Zero Adjust: ± 40 kHz range with 8552A, ± 12 kHz range with 8552B.

0-10f Scan Mode: With zero properly adjusted in PER DIVISION scan, 0 to 10f scan mode will scan from 0 (± 500 Hz or 0.2 div, whichever is greater) to ten times the scan width per division setting. Offset may be reduced to 0 readjusting frequency zero. Scan accuracy $\pm 5\%$.

Resolution: See Figure 1-3 for curves of typical 8556A/8552B/8552A Spectrum Analyzer resolution using different IF bandwidths. free dynamic range.

Warmup Drift: (Typical - first hour's operation.)

With 8552B: 500 Hz
With 8552A: 15 kHz

Long Term Drift: (Typical - at fixed center frequency after one hour warmup.)

With 8552B: 70 Hz/10 min
With 8552A: 400 Hz/10 min

Temperature Drift: (Typical.)

With 8552B: 200 Hz/ $^{\circ}$ C
With 8552A: 2 kHz/ $^{\circ}$ C

AMPLITUDE CHARACTERISTICS

Dynamic Range: For operation from 5 kHz to 300 kHz with signal levels greater than INPUT LEVEL setting, see Figure 1-4 for typical distortion.

Accuracy:

Log Reference Level: INPUT LEVEL and LOG REF LEVEL controls provide continuous log reference levels from +10 dBm/dBV to -80 dBm/dBV (may be decreased to -92 dBm/dBV by using 12 dB Log Reference Level Vernier).

Input Level: Provides 50 dB control of input preamplification and attenuation to prevent input overload. INPUT LEVEL markings of -60 dBm/dBV to -10 dBm/dBV indicate maximum input level for a minimum of 70 dB spurious

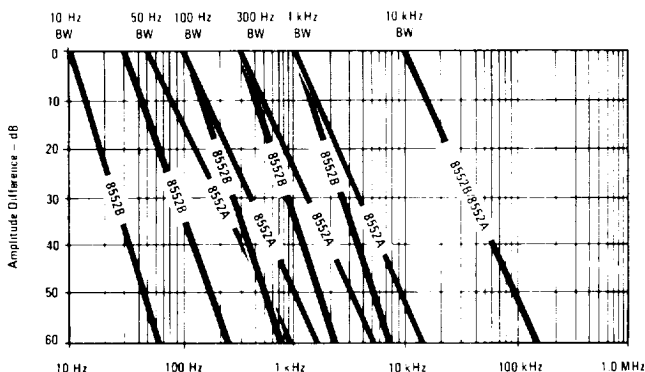
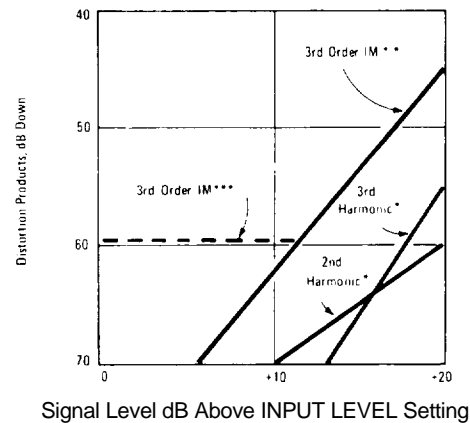

Figure 1-3. Typical Spectrum Analyzer



- * Single input signal, 300 Hz to 300 kHz. Second and third harmonic distortion products typically 10 dB higher below 30 Hz.
- ** Two input signals, 5 kHz to 300 kHz with > 300 Hz signal separation.
- *** Two input signals, frequency below 5 kHz with <300 Hz signal separation.

Figure 1-4. Typical Spectrum Analyzer Distortion Products

Table 1-2. Supplemental Performance Characteristics (cont'd)

AMPLITUDE CHARACTERISTICS (cont'd)

Accuracy ± 0.2 dB (2.3%). Input may be overloaded up to 20 dB with the analyzer still providing useful measurement capability. See Figure 1-4.

Log Reference Level Control: Provides 90 dB of IF gain control in 10 dB steps to cover log and linear ranges. Accurate to ± 0.2 dB ($\pm 2.3\%$).

Log Reference Level Vernier: Provides continuous 12 dB range. Accurate to ± 0.1 dB ($\pm 1.2\%$) in 0, -6, -12 dB positions; otherwise ± 0.25 dB ($\pm 2.8\%$).

Log Reference Level, switching between 10 dB/div and 2 dB/div log scales (8552B only):

Accuracy: ± 0.6 dB

Temperature Stability: ± 0.07 dB/ $^{\circ}$ C.

Amplitude Stability: ± 0.07 dB/ $^{\circ}$ C in log. ± 0.6 %/ $^{\circ}$ C in linear.

Display Uncalibrated Light: Warns if a combination of control settings (IF or video bandwidth, scan time or scan width) degrades absolute calibration for CW signals. Typically accurate to ± 1 position in scan width or scan time setting.

Video Filter: Averages displayed noise: bandwidth of 10 kHz, 100 Hz and (8552B only) 10 Hz. Bandwidth accuracy $\pm 20\%$.

DISPLAY CHARACTERISTICS**Variable Persistence/Storage (Model 141T):**

Plug-ins: Accepts Model 8550 series Spectrum Analyzer plug-ins and Model 1400 series time domain plug-ins.

Cathode-ray Tube:

Type: Post-accelerator storage tube, 9000 volt accelerating potential; aluminized P31 phosphor: etched safety glass faceplate reduces glare.

Graticule: 8 x 10 division (approximately 7.1 x 8.9 cm) parallax-free internal graticule: five subdivisions per major division on horizontal and vertical axes.

Persistence:

Normal: Natural persistence of P31 phosphor (approximately 0.1 second).

Variable:

Normal Writing Rate Mode: Continuously variable from less than 0.2 second to more than one minute (typically to two or three minutes).

Maximum Writing Rate Mode: Typically from 0.2 second to 15 seconds.

Erase: Manual: erasure takes approximately 350 ms; CRT ready to record immediately after erasure.

Storage Time: Normal writing rate; more than 2 hours at reduced brightness (typically 4 hours). More than one minute at maximum brightness.

Fast Writing Speed: More than 15 minutes (typically 30 minutes) at reduced brightness or more than 15 seconds at maximum brightness.

Functions Used with Time Domain Plug-ins Only: Intensity modulation, calibrator, beam finder.

Normal Persistence (Model 140T):

Plug-ins: Same as 141T.

Cathode-ray Tube:

Type: Post-accelerator. 7300 volt potential medium-short persistence (P7) phosphor, tinted and etched safety glass face-plate reduces glare. (Normal persistence of P7 phosphor approximately 3 sec.) Graticule: 8 x 10 division (approximately 7.6 x 9.5 cm) parallax-free internal graticule: five subdivisions per major division on horizontal and vertical axes.

Functions Used with Time Domain Plug-ins Only: Same as 141T.

Normal Persistence Large Screen Display (Model 143S):

Plug-ins: Same as 141T.

Cathode Ray Tube:

Type: Post-accelerator. 20 kV accelerating potential aluminized P31 phosphor. (Persistence approximately 0.1 sec.)

Graticule: 8 x 10 divisions (approximately 8 x 10-inch) parallax-free internal graticule. five subdivisions per major division on horizontal and vertical axes.

Functions Used with Time Domain Plug-ins Only: Same as 141T.

Table 1-2. Supplemental Performance Characteristics (cont'd)

GENERAL CHARACTERISTICS

Scan Mode:

Int: Analyzer repetitively scanned by internally generated ramp; synchronization selected by scan trigger.

Single: Single scan with reset actuated by front panel pushbutton.

Ext: Scan determined by 0 to +8 volt external signal; scan input impedance more than 10 k Ω .

Blanking: -1.5V external blanking signal required.

Manual: Scan determined by front panel control; continuously variable across CRT in either direction (8552B only).

Scan Trigger: For Internal Scan Mode, select between:

Auto: Scan free runs.

Line: Scan synchronized with power line frequency.

Ext: Scan synchronized with more than 2 volt (20 volt max.) trigger signal (polarity selected by internally located switch in Model 8552 IF Section).

Video: Scan internally synchronized to envelope of RF input signal (signal amplitude of 1.5 major divisions peak-to-peak required on display section CRT).

Auxiliary Outputs:

Vertical Output: Approximately 0 to -0.8V for 8 division deflection on CRT display; approximately 100 Ω output impedance.

Scan Output: Approximately -5 to +5V for 10 div CRT deflection, 5k Ω output impedance.

Pen Lift Output: 0 to 14V (0V, pen down). Output available in Int and Single Scan modes and Auto, Line, and Video Scan Trigger.

CRT Baseline Clipper: Front panel control adjusts blanking of CRT trace baseline to allow more detailed analysis of low repetition rate signals and improved photographic records to be made.

EMI: Conducted and radiated interference is within requirements of MIL-I-16910C and MIL-I-6181D and methods CE03 and RE02 of MIL-STD-461 (except 35 to 40 kHz) when 8556A and 8552B are combined in a 140T or 141T Display Section.

Temperature Range: Operating, 0°C to +55°C, storage, -40°C to +75°C.

Table 1-3. Operating Accessories

Model Number	Description
HP 10004A	10:1 Divider Probe (oscilloscope type)
HP 1001A	Probe to BNC Adapter
HP 1110A	Current Probe: Sensitivity: 1 mV/mA Bandwidth: 1700 Hz (3 dB down) 30 MHz(3 dB down) Electronic Counter
HP 5381A	Frequency Range: 10 Hz to 80 MHz Sensitivity: 25 mV Gate Time: 0.1, 1 and 10 sec. Resolution: 1 Hz Readout: 7 digits Input Impedance: 1 Megohm
HP 4437A	600 ohm Unbalanced Attenuator Range: 0-119.9 dB in 0.1 dB increments Accuracy: ± 0.2 dB to 90 dB ± 0.5 dB to 110 dB ± 1.0 dB to 119.9 dB Input Power: 1 watt max
HP 197A	Oscilloscope Camera

Table 1-4. Test Equipment

Item	Minimum Specifications	Suggested Model	Use*
AC Voltmeter	Voltage Range: 1 mV to 10V full scale (-10 to +2 dB on dB scale) Frequency Range: 20 Hz to 400 kHz Accuracy: ± (2.5% of full scale +2.5% of reading) AC to DC Converter Output: 1V dc for full scale meter deflection AC to DC Converter Accuracy: ± (1% of full scale +1% of reading) Input Impedance: 10 MΩ shunted by ≈ 25 pF	HP 400EL	P,A,T
Oscilloscope	Frequency Range: dc to 50 MHz AC or DC Coupling Sensitivity: 0.005 V/DIV Voltage Accuracy: ±3%	HP 180A/ 1801A/ 1820B	A, T
X10 Oscilloscope Probe (2)	Resistance: 10 MΩ shunted by 10 pF Division Accuracy: 3%	HP 10004A	A, T
*Use: Performance = P; Adjustment = A; Troubleshooting = T			

Table 1-4. Test Equipment (cont'd)

Item	Minimum Specifications	Suggested Model	Use*
Frequency Counter	Range: 0-60 MHz Sensitivity: 0.1V rms sine wave Display: 7 digits Accuracy: $\pm 0.001\%$	HP 5327C	P, A, T
Digital Voltmeter (2 required) for performance tests)	Display: 4 digits Range: 0 to 100.0 V full scale 0 to 1000.0 K ohms full scale Accuracy: $\pm (0.02\% \text{ of reading} + 0.05\% \text{ of range})$ Polarity: automatic indication	HP 3480B, 3484A Opt. 042	P, A, T
L-C Meter	Range: 10 to 40 pF Accuracy: within 3% of full scale	Tektronix Type 130	A
Test Oscillator	Frequency Range: 20 Hz to 300 kHz Dial Accuracy: $\pm 3\%$ Max Output: > 3.0V into 50 or 600 ohms Flatness: $\pm 3\%$ Distortion: < 1% Output Monitor: voltmeter monitors output level at input of attenuator in volts or dB; accurate to $\pm 2\%$ of full scale Attenuator: range, 90 dB in 10 dB steps accuracy, ± 0.075 dB, -60 dBm to +20 dBm	HP 651B	P, A, T
Oscillator	Frequency Range: 30 Hz to 100 Hz Dial Accuracy: $\pm 3\%$ Max Output: 2.5 V into 600 ohms Distortion: 0.1% (60 dB) Hum and Noise: <0.01% of output	HP 204D	P
Filter Set	Selectable 500 Hz and 50 kHz Bandpass Filters: > 30 dB of attenuation to second harmonic: > 40 dB of attenuation to third and higher harmonics	White Model 2640	P
Spectrum Analyzer Only		HP 8556A/8552B/141T	P

*Use: Performance = P; Adjustment A. Troubleshooting = T

Table 1-5. Test Equipment Accessories

Item	Minimum Specifications	Suggested Model	Use*
BNC Tee	One BNC male, two BNC female connectors	HP 1250-0781	P
Adapter	Selectro Plug to BNC Jack	HP 1250-1236	A, T
Adapter	Selectro Jack to BNC Jack	HP 1250-1237	A, T
Adapter	UHF Plug to BNC Jack (UG-273/U)	HP 1250-0071	A
Cable Assy	Male BNC to Dual Banana Plug, 45 inches long	HP 11001A	P
Cable Assy	Male BNC Connectors, 24 inches long	HP 11086A	A
Cable Assy	Dual Banana Plugs, 44 inches long	HP 11000A	P
Cable Assy(2)	Male BNC Connectors, 48 inches long	HP 10503A	P, A, T
Cable Assy	Dual Banana Plug to Alligator Clips, 5 feet long	HP 11002A	A, T
Extender Board	10 Pins, 20 Conductors, for plug-in circuit boards	HP 5060-0256	A, T
Screwdrivers	Phillips No. 1 Phillips No. 2 Pozidriv No. 1 (Stanley No. 5531) Pozidriv No. 2 (Stanley No. 5332)	HP 8710-0899 HP 8710-0900	A, T A, T A, T A, T
Tuning Tool	Non-Metallic Shaft (J.F.D. Model No. 5284)	HP 8710-1010	A
50-Ohm Feed Thru Termination	Supplied with 8556A	HP 11048B	P, A, T
600-Ohm Feed Thru Termination	Supplied with 8556A	HP 11095A	P, A, T
Tracking Gen Shunt	Supplied with 8556A	HP 11660A	P
Service Kit	Contents: Display Section to Spectrum Analyzer Extender Cable Assembly (HP 11592-60015) Tuning Section to IF Section Interconnection Cable Assembly (HP 11592-60016) Selectro Female to BNC Male Test Cable ,3 each, 36 inches long (HP 11592-60001) Selectro Male to Selectro Female Test Cable, 2 each, 8 inches long (HP 11592-60003)	HP 11592A	A, T
*Use: Performance = P: Adjustment =A: Troubleshooting = T			

Table 1-5. Test Equipment Accessories (cont'd)

Item	Minimum Specifications	Suggested Model	Use*
Service Kit (cont'd)	Selectro Female to Selectro Female Test Cable, 2 each, 8 inches long (HP 11592-60002) Extender Board Assembly, 15 pins, 30 conductors, for plug-in circuit boards (HP 11592-60011) Fastener Assembly (2 each: HP 11592-2001 and HP 1390-0170) Selectro Jack-to-Jack Adapter (HP 1250-0827) Wrench, open end, 15/16 inch (HP 8710-0946) BNC Jack-to-OSM Plug Adapter (HP 1250-1200) OSM Plug-to-Plug Adapter (HP 1250-1158) Cable Assembly R and P Connector (HP 11592-60013)	HP 11592A	A, T

* Use: Performance = P: Adjustment = A: Troubleshooting = T.

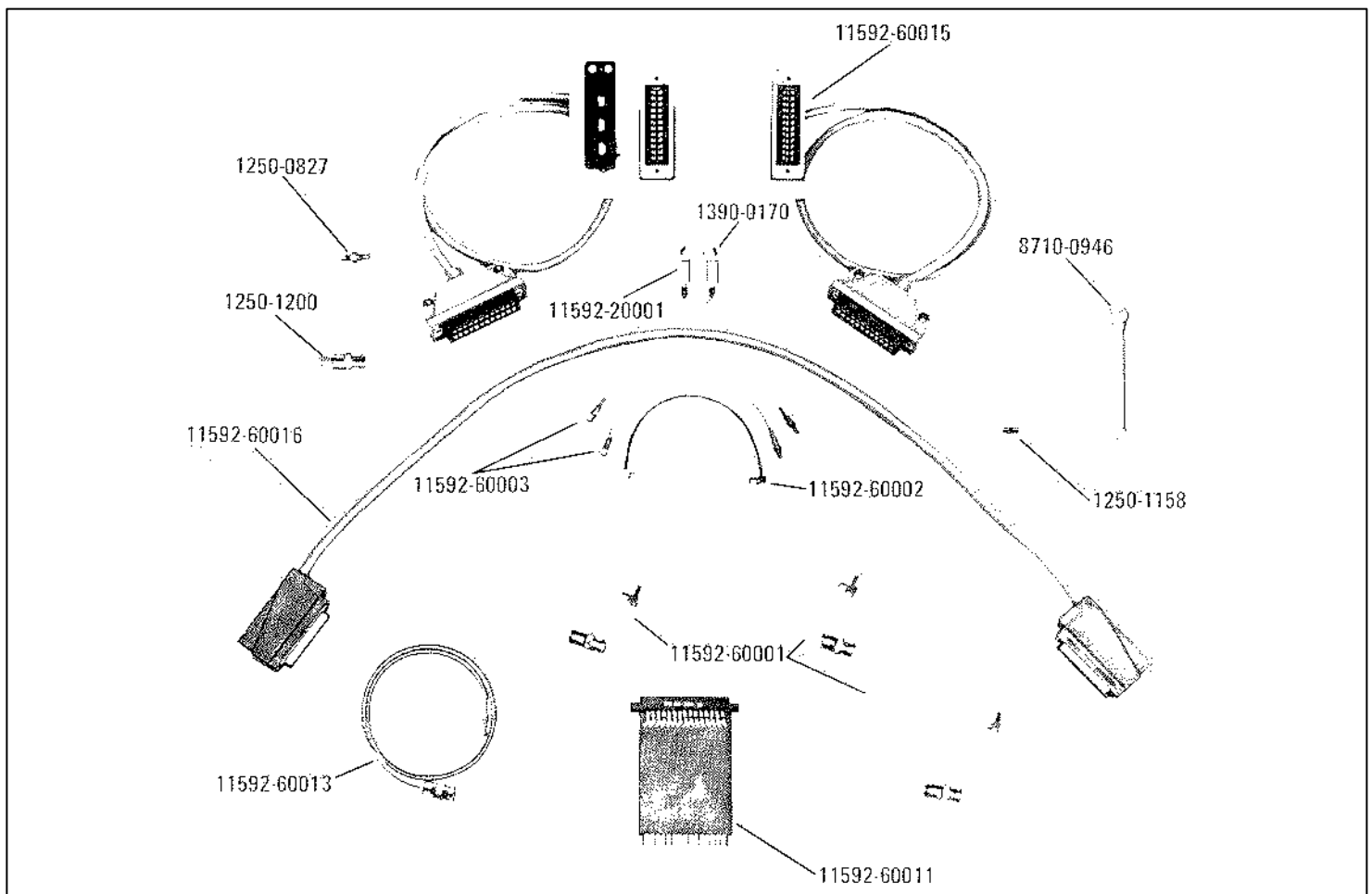

Figure 1-5. HP 11592A Service Kit

SECTION II

INSTALLATION

2-1. INITIAL INSPECTION

2-2. Mechanical Check

2-3. Check the shipping carton for evidence of damage immediately after receipt. If there is any visible damage to the carton, request the carrier's agent be present when the instrument is unpacked. Inspect the instrument for physical damage such as bent or broken parts and dents or scratches. If damage is found refer to paragraph 2-6 for recommended claim procedures. If the instrument appears to be undamaged, perform the electrical check (see paragraph 2-4). The packaging material should be retained for possible future use.

2-4. Electrical Check

2-5. The electrical check consists of following the performance test procedures listed in Section IV. These procedures allow the operator to determine that the instrument is, or is not, operating within the specifications listed in Table 1-1. The initial performance and accuracy of the instrument are certified as stated on the inside front cover of this manual. If the instrument does not operate as specified, refer to paragraph 2-6 for the recommended claim procedure.

2-6.

2-7. DELETED

2-8.

2-9. PREPARATION FOR USE

CAUTION

Before applying power, check the rear panel slide switch on the Display Section for proper position (115 or 230 volts).

2-10. Shipping Configuration

2-11. Because of individual customer requirements, shipping configurations are flexible. Preparation for use is based on the premise that the LF and IF Sections are installed in a Display Section; thus, the Spectrum Analyzer is physically and functionally complete for use. Since the LF and IF Sections are usually received separately, the plug-ins must be mechanically fitted

WARNING

INPUT connector ground is isolated from cabinet ground. Any voltage present on cable shield will be present on connector shell (± 100 VDC maximum). If contacted, this voltage may cause personal injury.

together, electrically connected and inserted in a display section or oscilloscope mainframe of the 140-series. For mechanical and electrical connections, refer to Figure 2-1 and paragraph 2-20.

2-12. Power Requirements

2-13. The Spectrum Analyzer can be operated from a 50 to 60 hertz input line that supplies either a 115 volt or 230 volt ($\pm 10\%$ in each case) power. Consumed power varies with the plug-ins used but is normally less than 225 watts. Line power enters the Display Section or Mainframe, where it is converted to dc voltages, and then is distributed to the LF and IF Sections via internal connectors.

2-14. The 115/230 power selector switch at the rear of the Display Section must be set to agree with the available line voltage. If the line voltage is 115 volts, the slide switch must be positioned so that 115 is clearly visible. The instrument is internally fused for 115 volt operation, when shipped. If 230 volt source is to be used, refer to fuse replacement procedures in the Display Section manual.

2-15. Power Cable

2-16. To protect operating personnel, the National Electrical Manufacturers Association (NEMA) and the International Electrotechnical Commission (IEC) recommends that the instrument panel and cabinet be grounded. The Spectrum Analyzer is equipped with a three-conductor power cable: the third conductor is the ground conductor, and when the cable is plugged into an appropriate receptacle, the instrument is grounded. To preserve the protection feature when operating the instrument from a two-contact outlet, use a three-prong to two-prong adapter and connect the green lead on the adapter to ground.

2-17. Operating Environment

2-18. The Spectrum Analyzer uses a forced-air cooling system to maintain required operating temperatures within the instrument. The air intake and filter are located on the rear of the Display Section; air is exhausted through the side panel perforations.

When operating the instrument, choose a location which provides at least three inches of clearance around the rear and both sides. Refer to the Display Section manual for maintenance instructions for the cooling system.

2-19. Interconnections

2-20. The LF and IF Sections are normally shipped separately; the plug-ins must be mechanically fitted together, electrically connected, and then inserted in the Display Section or mainframe. To make these connections, refer to Figure 2-1 and proceed as follows:

a. Set the IF Section on a level bench. Locate slot near right rear corner of LF Section: also, locate metal tab on IF Section that engages with this slot.

b. Grasp the 8556A LF Section near middle of chassis and raise until it is a few inches above the IF Section.

c. Tilt LF Section until front of assembly is about 2 inches higher than the rear.

d. Engage assemblies in such a way that metal tab on the rear of the IF Section slips through the slot on LF Section.

e. With the preceding mechanical interface completed, gently lower LF Section until electrical plug and receptacle meet.

f. Position LF Section as required to mate the plug and receptacle. When plug and receptacle are properly aligned, only a small downward pressure is required to obtain a snug fit.

g. After the LF and IF Sections are joined mechanically and electrically, the complete assembly is ready to insert in the Display Section.

h. Pick up the LF/IF Sections and center in opening of Display Section. Push forward until assembly fits snugly into Display Section.

i. Push in front panel latch to securely fasten assembly in place.

2-21. To separate the LF/IF Sections from Display Section and to separate the LF Section from the IF Section, proceed as follows:

a. Push front panel latch in direction of arrow until it releases.

b. Firmly grasp the middle of latch flange and pull LF/RF Sections straight out.

c. Locate black press-to-release level near right front side of LF Section. Press this lever and simultaneously exert an upward pulling force on front edge of LF Section.

d. When the two sections separate at the front, raise LF Section two or three inches and slide metal tab at rear of IF Section out of the slot in which it is engaged.

2-22. STORAGE AND SHIPMENT**2-23. Original Packaging**

2-24. The same containers and materials used in factory packaging may be used.

2-25. If the instrument is being returned to Hewlett-Packard for servicing, attach a tag indicating service required, return address, instrument model number and full serial number. Mark the container FRAGILE to assure careful handling.

2-26. In any correspondence refer to the instrument by model number and full serial number.

2-27. Other Packaging Materials

2-28. The following general instructions should be followed when repackaging with commercially available materials:

a. Wrap the instrument in heavy paper or plastic. If shipping to a Hewlett-Packard Service Office or Center attach a tag indicating the type of service required, return address, model number and full serial number.)

b. Use a strong shipping container. A double wall carton made of 350 pound test material is adequate.

c. Use enough shock-absorbing material (three to four-inch layer) around all sides of the instrument to provide firm cushion and prevent movement inside the container. Protect the control panel with cardboard.

d. Seal the shipping container securely.

e. Mark the shipping container FRAGILE to assure careful handling.

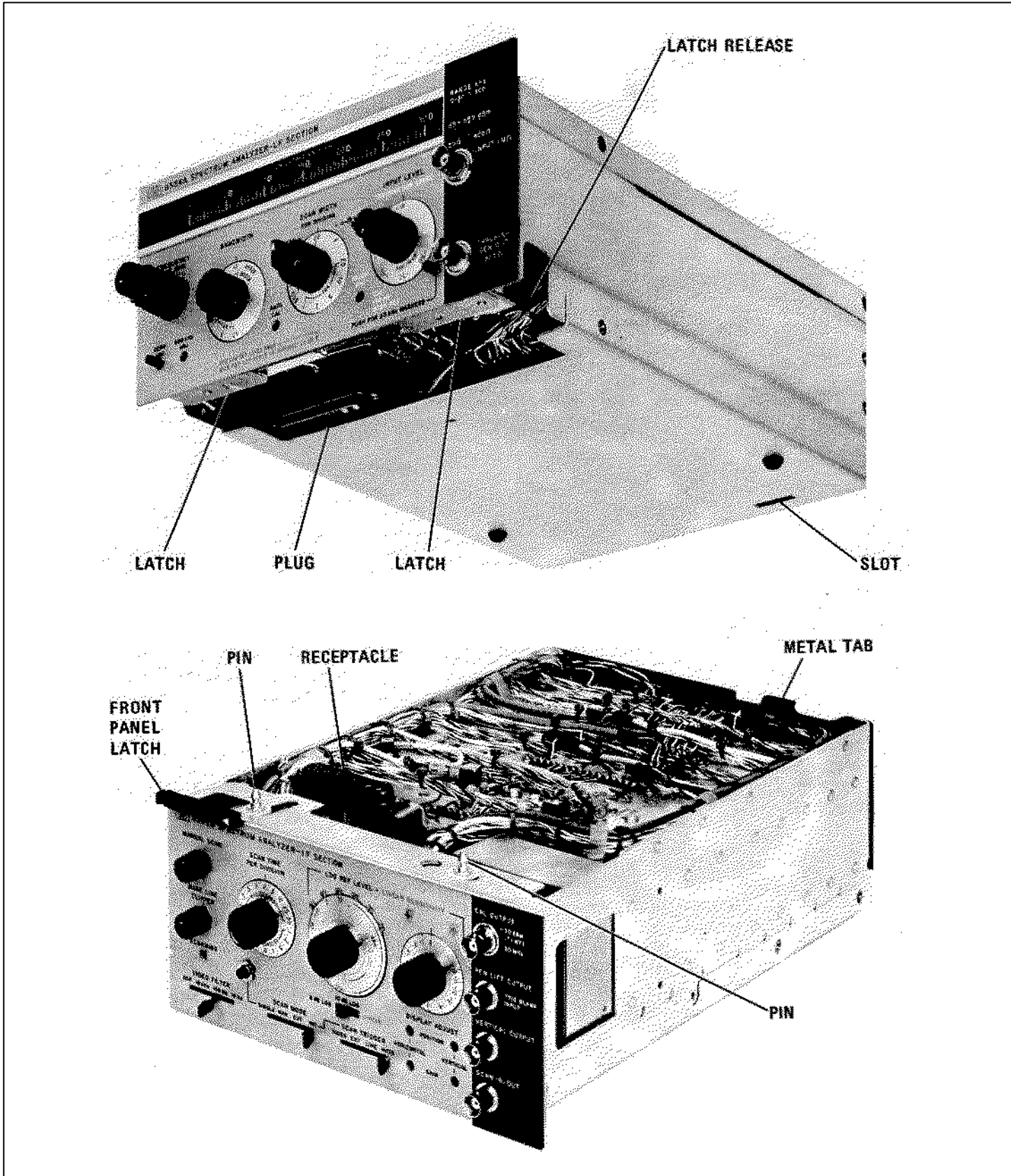

Figure 2-1. LF Section and IF Section Interconnections

SECTION III OPERATION

3-1. INTRODUCTION

3-2. This section provides complete operating instructions for the HP 8556A Spectrum Analyzer LF Section as used with an 8552 series IF Section and a 140 series Display Section.

3-3. PANEL FEATURES

3-4. Front panel controls, indicators and connectors are shown and briefly described in Figure 3-1. Rear panel controls and connectors are shown and described in Figure 3-2. For a detailed description of IF Section and Display Section controls and indicators, refer to their manuals.

3-5. OPERATOR'S CHECKS

3-6. Upon receipt of the analyzer, or when any plug-in is changed, perform the operational adjustments listed in Figure 3-2. This procedure corrects for minor differences between units and ensures that the LF Section, IF Section and Display Section are properly matched.

3-7. OPERATING CONSIDERATIONS

3-8. Front panel controls, indicators and connectors are shown and briefly described in Figure 3-1. The following information covers general operating considerations.

3-9. RF Input

3-10. The 8556A has an input impedance of 1 Megohm, shunted by approximately 32 pF, so compensated oscilloscope probes (see Table 1-3) can be connected directly to INPUT and used for in-circuit testing. To compensate an oscilloscope probe for use with the 8556A, use the probe's BNC adaptor to connect the probe tip to TRACKING GEN OUT. Adjust the probe for optimum signal flatness on the CRT display.

3-11. Use the feedthrough terminations, 50 ohm and 600 ohm, when the device to be tested must be terminated in its characteristic impedance (for example, when measuring dBm). To make a feedthrough termination for some other impedance, simply connect a resistor across the analyzer INPUT (connect the resistor to INPUT ground, not chassis ground). The value of the resistor should be equal to the characteristic impedance of the device.

CAUTION

**Do not apply more than 10 V rms and
±200 Vdc to INPUT.**

3-12. Amplitude Ranges

3-13. The LOG/LINEAR switch on the IF Section works in conjunction with the dBm/dBV switch on the LF Section. With LINEAR selected, the analyzer measures voltage. With LOG selected (either 2 dB or 10 dB on the 8552B), the analyzer measures voltage in dBV (that is, dB referenced to 1 volt) or power in dBm. The LF Section is calibrated to measure dBm in 50 or 600 ohms.

3-14. To use 2 dB LOG, first find the signal using 10 dB LOG; display the desired portion of the signal on the top 16 dB of the CRT display, then switch to 2 dB LOG. The top of the display, the LOG REF graticule, remains the same. The -70 dB graticule line becomes -14 dB (each major division becomes 2 dB).

NOTE

**Do not make any VERTICAL GAIN or
POSITION adjustments in 2 dB LOG
as the front panel calibration will
become invalid.**

3-15. The LOG REF LEVEL control on the IF Section has three scales (see EQUIPMENT SUPPLIED in Section I): the red scale is used for LF Section log calibration, the black scale is used for RF Section log calibration, and the blue scale is used for linear calibration on all units. If the IF Section being used does not have the red scale, subtract 20 dB from the black scale to obtain the LOG REF level on the CRT.

3-16. First Mixer Balance

3-17. The first mixer in the 8556A is balanced to insure a low level of first local oscillator feedthrough appearing on the display. Excessive LO feedthrough may result in inaccurate amplitude calibration and excessive intermodulation distortion. With the dBm/dBV switch set to 50Ω dBm and INPUT LEVEL set to -60 dBm/dBV, the first LO feedthrough (zero frequency marker) should be below -80 dBm. If it is above this level, perform the first mixer balance adjustment specified below.

3-18. Remove the top cover from the Display Section (with power off).

WARNING

Removing the top cover from the Display Section exposes the operator to dangerous potentials (up to 7000 volts).

3-19. Set the analyzer controls as follows:

FREQUENCY	0 kHz
BANDWIDTH.....	3 kHz
SCAN WIDTH	PER DIVISION
PER DIVISION	10 kHz
INPUT LEVEL	-60 dBm/dBV
dBm/dBV	50 Q2 dBm
BASE LINE CLIPPER	ccw
VIDEO FILTER.....	10 kHz
SCAN TIME PER DIVISION	5 MILLISECONDS
LOG/LINEAR	10 dB LOG
LOG REF LEVEL	-40 dBm
SCAN MODE	INT
SCAN TRIGGER	AUTO
POWER	ON

NOTE

This procedure assumes that the analyzer is calibrated as specified in Figure 3-2 and has been allowed to warm up at least one-half hour.

3-20. Center the LO feedthrough signal on the display with the FREQUENCY control.

3-21. Using a non-metallic adjustment tool, alternately adjust C and R MIXER BALANCE ADJUSTMENTS (available on the LF Section top cover) to null the LO feedthrough.

3-22. When the signal is below -80 dBm, turn power off and replace the top cover.

3-23. OPERATING INSTRUCTIONS

3-24. The following instructions should enable an operator to make fast, accurate measurements with the low frequency analyzer. To define each instrument application is beyond the scope of this manual. For further details, there is a complete discussion of 8556A applications in Application Note 134. This application note is available from your local HP Sales and Service Office.

3-25. In general, operation of the Spectrum Analyzer may be accomplished through the following steps:

- a. Set the analyzer to scan the appropriate frequency range with the proper resolution.
- b. Adjust the amplitude scale as necessary for the measurement.
- c. Complete the measurement, and interpret the results.

3-26. Setting the Frequency Scan

3-27. There are three ways to set the frequency scan on the 8556A. The first is the 0-10f mode of operation. When this mode is selected, the spectrum analyzer scans from "zero" frequency to a preset upper limit selected by the PER DIVISION control. For example, if the PER DIVISION control is set to 10 kHz, and the 0-10f mode is selected, the spectrum analyzer will scan from 0 to 100 kHz, 10 kHz per division. Scans may be selected from 20 Hz per division to 20 kHz per division in a 1, 2, 5 sequence.

3-28. The second way to set the frequency scan is the PER DIVISION mode. In this mode, the frequency scan is symmetrical about the CENTER FREQUENCY tuned by the FREQUENCY control. The CENTER FREQUENCY dial indicates this frequency in two ranges, 0-30 kHz or 0-300 kHz. The horizontal scale is then selected by the PER DIVISION setting.

3-29. The third way is the ZERO scan mode. The spectrum analyzer becomes a fixed-tuned receiver at the frequency indicated by the CENTER FREQUENCY dial. In this mode, amplitude variations are displayed versus time on the CRT.

3-30. Once the proper frequency scan is chosen, the resolution needed for the particular measurement should be determined. Resolution is mainly a function of the IF bandwidth selected. As narrower IF bandwidths are used, the resolution increases. At the same time, the spectrum analyzer must be swept at a slower rate. The bandwidth used should be only as narrow as is necessary for the particular application. The best procedure is to select the bandwidth necessary for the desired resolution, and then slow the scan rate (SCAN TIME PER DIVISION) until the DISPLAY UNCAL light is unlit.

3-31. Adjusting the Amplitude Scale 3-32. Once the desired signals are displayed on the CRT the amplitude is set to give an optimum display. The first consideration is how the amplitude is to be measured. The 8556A can measure power in dBm (for 50 ohm or 600 ohm systems), and it can measure voltage on a linear scale or in dB referred to one volt (dBV) on a log scale.

3-33. If power is the desired parameter, set the dBm/dBV switch to dBm for the appropriate

FRONT PANEL FEATURES

- (1) **DISPLAY UNCAL:** warning light indicates that the CRT display has become uncalibrated due to incompatible settings of SCAN WIDTH, SCAN TIME PER DIVISION, BANDWIDTH, and VIDEO FILTER controls.
- (2) **FREQUENCY:** tunes the CENTER FREQUENCY in SCAN WIDTH PER DIVISION and ZERO scan modes. FINE TUNE allows high resolution adjustments in narrow scans.
- (3) **ZERO ADJ:** calibrates CENTER FREQUENCY dial for "zero" frequency.
- (4) **300 kHz ADJ:** calibrates CENTER FREQUENCY dial for 300 kHz.
- (5) **BANDWIDTH:** selects resolution bandwidth of the spectrum analyzer from 10 Hz to 10 kHz in a 1, 3 sequence. (8552A, 50 Hz and 100 Hz to 300 kHz in a 1, 3 sequence.)
- (6) **AMPL CAL:** calibrates display amplitude for absolute voltage and power measurements.
- (7) **CENTER FREQUENCY:** dial indicates the CENTER FREQUENCY for SCAN WIDTH PER DIVISION and ZERO scan modes. Calibrated in 5 kHz increments for 0-300 kHz range and 500 Hz increments for 0-30 kHz range.
- (8) **SCAN WIDTH:** selects spectrum analyzer frequency scanning mode. 0-10f repetitively tunes the spectrum analyzer from "zero" frequency to ten times the setting of the PER DIVISION control. (e.g., with PER DIVISION control set at 1 kHz, scan would be from 0-10 kHz, or 1 kHz per division.) PER DIVISION mode scans the spectrum analyzer symmetrically about the CENTER FREQUENCY with a scan width set by the PER DIVISION control. In the ZERO scan mode, the analyzer becomes a fixed frequency receiver at the CENTER FREQUENCY.
- (9) **PER DIVISION:** selects the CRT horizontal calibration (frequency scale) in the PER DIVISION and 0-10f frequency scan modes.
- (10) **TRACKING ADJ:** tunes the TRACKING GEN OUT frequency to precisely track the tuning frequency of the spectrum analyzer.
- (11) **INPUT LEVEL:** adjusts the input signal level to the input mixer and input preamplifier to maximize dynamic range. This control should be set to agree with the signal level read on the CRT.
- (12) **TRACKING GEN LEVEL:** adjusts the output level of the tracking signal present at the TRACKING GEN OUT. When the CAL position is selected, it gives an output of 100 mV for calibrating the spectrum analyzer display. The output can be increased to 3V.
- (13) **RANGE kHz:** selects CENTER FREQUENCY dial range of 0-30 kHz or 0-300 kHz.
- (14) **INPUT:** one megohm unbalanced input for signals to be measured.
- (15) **dBm/dBV:** selects log display absolute calibration for dB1V or dBm referred to 50 ohms or 600 ohms. For correct dBm measurements, an external termination of the proper impedance must be provided for the input signals.
- (16) **TRACKING GEN OUT:** output signal tracks the spectrum analyzer tuning frequency. The signal may be used for swept frequency response measurements or to drive a frequency counter for accurate frequency measurements. The signal output also serves to accurately calibrate the display for absolute amplitude.
- (17) **kHz MARKERS:** places crystal controlled markers with 20 kHz spacing on CRT. These markers are accurate to 0.01%, and are useful for calibrating the frequency axis.
- (18) **CAL OUTPUT:** -30 dBm, 30 MHz signal used for calibrating amplitude on other tuning sections (8553B,8554L,8555A).
- (19) **PEN LIFT OUTPUT, TRIG/BLANK INPUT:** provides -14 V pen lift signal for use with X-Y recorders during retrace in SINGLE and INT SCAN MODES with VIDEO. LINE, or AUTO SCAN TRIGGER. It serves as an input connector for external blanking signal in the EXT SCAN MODE. When EXT SCAN TRIGGER is selected, it becomes an input connector for the external trigger signal.
- (20) **VERTICAL OUTPUT:** provides output proportional to vertical deflection on CRT. Approximately 100 mV per major division with 100 ohm output impedance.

Figure 3-1. Front Panel Features (1 of 4)

FRONT PANEL FEATURES

- (21) **SCAN IN/OUT:** provides output voltage proportional to CRT horizontal deflection. 0 volts equals center screen with 1 volt per division (-5 to +5V full screen). Output voltage available in SINGLE, MAN, and INT SCAN MODES. In EXT SCAN MODE, the connector is used as an input for 0 to +8V external scan signal.
- (22) **DISPLAY ADJUST:** these controls adjust the deflection circuit gain and offset levels to match the IF section to a particular display section.
- (23) **LOG REF LEVEL LINEAR SENSITIVITY:** these controls set the absolute amplitude calibration of the CRT display. In the 10 dB LOG or 2 dB LOG modes, the sum of the two control settings determines the LOG REF LEVEL (top graticule line on CRT). In the LINEAR mode, the product of the two control settings determines the CRT scale factor in volts per division. A special knob is provided for use with the 8556A. This knob is described under OPERATING CONSIDERATIONS (paragraph 3-15).
- (24) **LOG/LINEAR:** selects display mode for logarithmic display with scale factors of 10 dB per division or 2 dB per division or LINEAR display with scale factor selected by LINEAR SENSITIVITY (2 dB per division not available with 8552A).
- (25) **SCAN TRIGGER:** selects synchronizing trigger when in the INT SCAN MODE.
- AUTO:** scan free runs.
- LINE:** scan synchronized to power line frequency.
- EXT.:** scan initiated by external positive or negative pulses (2-20V) applied to TRIG/BLANK INPUT.
- VIDEO:** scan internal synchronized to envelope of RF input signal. Signal amplitude of 1.5 divisions peak-to-peak (min.) required on display section CRT.
- (26) **SCAN MODE:** selects scan source.
- INT.:** analyzer repetitively scanned by internally generated ramp; synchronization selected by SCAN TRIGGER. SCANNING lamp indicates time during which analyzer is being scanned.
- EXT.:** scan determined by externally applied 0 to +8V signal at SCAN IN/OUT.
- MAN:** scan determined by MANUAL SCAN control; scan continuously variable across CRT in either direction. (Not available with 8552A.)
- SINGLE:** single scan initiated by front panel pushbutton. SCANNING lamp indicates time during which analyzer is being scanned.
- (27) Initiates or resets scan when SINGLE SCAN MODE is selected.
- (28) **SCAN TIME PER DIVISION:** selects time required to scan one major division on CRT display. Control acts as time base for time domain operation in ZERO scan.
- (29) **VIDEO FILTER:** post detection low pass filter for effective averaging of distributed signals such as noise.
- (30) Bandwidths of 10 kHz, 100 Hz, and 10 Hz selectable; nominal bandwidth 400 kHz in OFF position. (10 Hz position not available with 8552A.) **BASE LINE CLIPPER:** allows blanking of the bright base line area of the CRT for better photography and improved display of transient phenomena.
- (31) **MANUAL SCAN:** controls spectrum analyzer horizontal scan in the MAN SCAN MODE. (Not available on 8552A.)
- (32) **CAL 10V and 1V:** 10V or 1V square wave used to calibrate time domain plug-ins ONLY.
- (33) **FOCUS:** focuses CRT spot for best definition.
- (34) **BEAM FINDER:** returns CRT trace to the center of the screen regardless of deflection potentials with time domain plug-ins ONLY.
- (35) **NON STORAGE, CONV:** defeats the storage and variable persistence features of the CRT. Persistence is that of the standard P31 phosphor.
- (36) **INTENSITY:** adjusts the intensity of the trace on the CRT.
- CAUTION**
- Excessive INTENSITY will damage the CRT storage mesh. Whenever trace blooming occurs, turn INTENSITY down.**
- (37) **ERASE:** erases the CRT in the WRITING SPEED FAST or STD mode of operation. CRT ready to record immediately after erasure.

Figure 3-1. Front Panel Features (2 of 4)

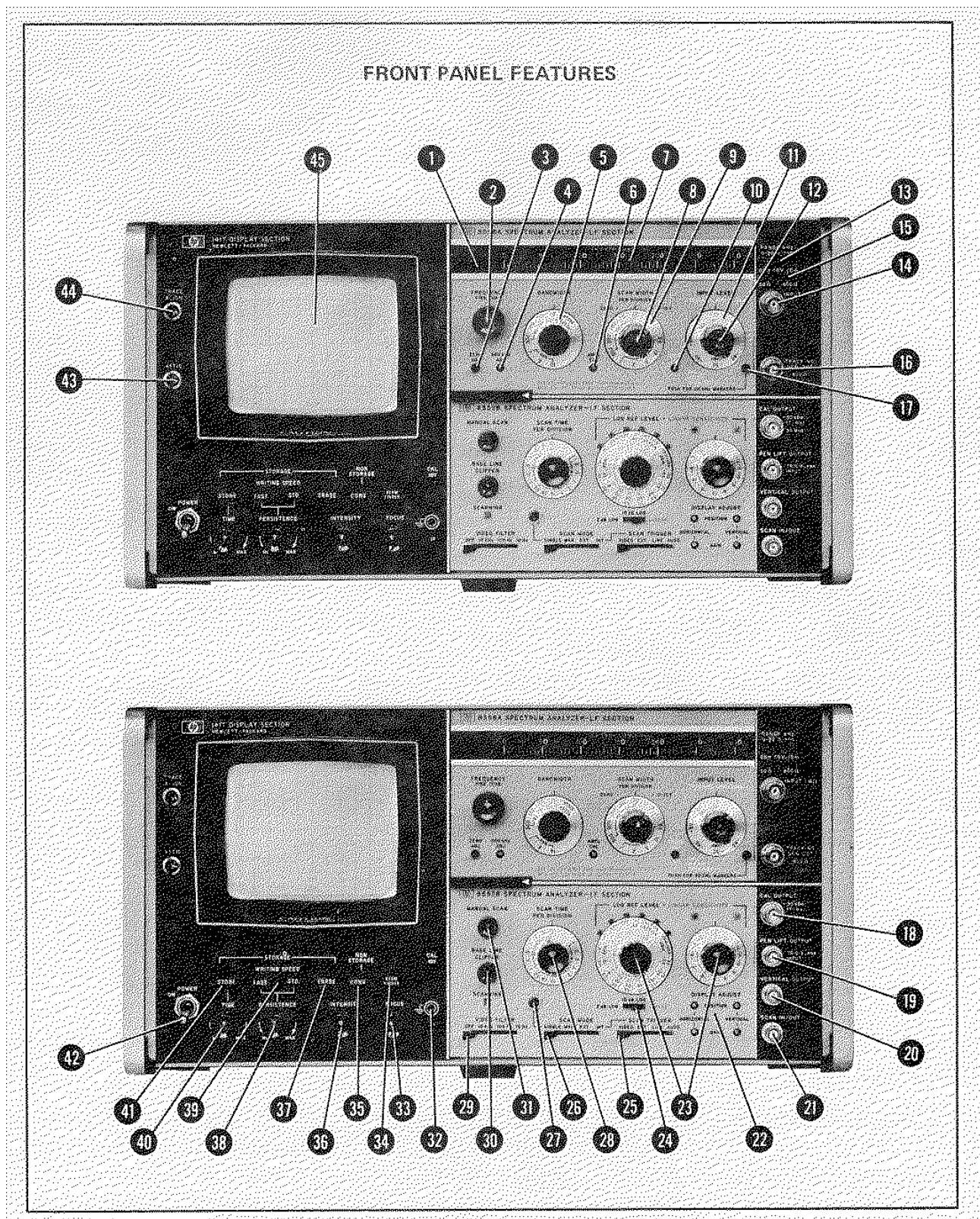

Figure 3-1. Front Panel Features (4 of 4)

FRONT PANEL FEATURES

- (38) **PERSISTENCE:** adjusts the trace fade rate from 0.1 sec. to more than 2 minutes in the WRITING SPEED FAST or STD modes of operation.
- (39) **WRITING SPEED FAST, STD:** these controls select the writing speed of the CRT in the PERSISTENCE mode of operation. The WRITING SPEED STD mode is almost always selected for spectrum analysis applications.
- (40) **STORE TIME:** controls the storage time and relative brightness of the display in the STORE mode of operation. Storage time more than 2 minutes at maximum brightness, more than 2 hours at minimum brightness.
- (41) **STORE:** stores the display on the CRT for extended viewing or photography. The CRT does not write in the STORE mode.
- (42) **POWER:** controls power to the mainframe and to both plug-ins.
- (43) **ASTIG:** adjusts the shape of the CRT spot.
- (44) **TRACE ALIGN:** used to adjust the CRT trace to align with the horizontal graticule lines.
- (45) **CRT Graticule with LOG and LIN scales.** LOG REF is the level used to reference the amplitude of displayed signals in the LOG display mode. LINEAR display amplitude is referenced from the baseline.

OPERATIONAL ADJUSTMENTS

(1) INPUT POWER

a. Set 115/230 switch to correspond with available input voltage. (The instrument is fused for 115 volt, 50/60 Hz operation; if 230 volt power is used, refer to the Display Section service manual for fuse replacement procedures.)

b. Connect line power cord to instrument jack and to a line power outlet.

(2) INTENSITY MODULATION

Set INT/EXT switch to INT. (Set to EXT only if CRT Z axis is to be externally modulated normally only used with 1400 series oscilloscope plug-ins).

(3) FOCUS AND ASTIGMATISM

- a. Make the following instrument control settings:
- RANGE0-300 kHz
 - FREQUENCY 150 kHz
 - FINE TUNE Centered
 - BANDWIDTH..... 10 kHz
 - SCAN WIDTH..... PER DIVISION
 - PER DIVISION 20 kHz
 - INPUT LEVEL-20 dBm/dBV
 - dBm/dBV dBV
 - 20 kHz MARKERS Out
 - SCAN TIME PER DIVISION 5 MILLISECONDS
 - LOG REF LEVEL-10 dBV
 - Vernierccw
 - LOG/LINEAR 10 dB LOG
 - VIDEO FILTER OFF
 - SCAN MODEINT
 - SCAN TRIGGERAUTO
 - BASE LINE CLIPPERccw
 - WRITING SPEED..... STD
 - PERSISTENCEMIN
 - INTENSITY12 o'clock
 - POWERON

b. Adjust INTENSITY as needed. (Whenever blooming occurs on CRT, turn INTENSITY down.) Set LOG REF LEVEL maximum counterclockwise. Using the VERTICAL POSITION control, bring the trace to the 50 dB graticule line.

c. Switch the SCAN MODE to MAN, and use the MANUAL SCAN to bring the CRT dot to the center of the screen. Adjust FOCUS and ASTIG for the smallest round dot possible.

(4) TRACE ALIGNMENT

Set SCAN MODE to INT. Adjust TRACE ALIGN to set the trace parallel to the horizontal graticule lines.

(5) HORIZONTAL POSITION AND GAIN

a. Alternately adjust HORIZONTAL GAIN and HORIZONTAL POSITION so that the trace just fills the horizontal graticule line.

b. Using the VERTICAL POSITION control, bring the trace to the bottom graticule line (ignore any slight misalignment of the trace).

(6) VERTICAL POSITION AND GAIN

a. Connect TRACKING GEN OUT to the INPUT (do NOT use a feedthrough termination). Set the TRACKING GEN LEVEL to CAL. Set the VIDEO FILTER to 10 kHz. Use the LOG REF LEVEL vernier to set the trace to the -70 dB graticule line at the center of the CRT. (Adjust AMPL CAL counterclockwise, if necessary, to lower trace.)

b. Turn the LOG REF LEVEL clockwise 7 steps (without moving vernier) while observing the trace. The trace should move up the CRT in 10 dB steps. If it does not, adjust VERTICAL GAIN to bring the trace to the top graticule line.

c. Turn the LOG REF LEVEL fully counterclockwise and repeat steps 6 a. and 6 b. until no further adjustment is necessary.

(7) AMPLITUDE CALIBRATION

a. Set the LOG REF LEVEL to -20 dBV (set vernier to zero). Adjust AMPL CAL to bring the trace to the top graticule line at the center of the screen.

b. Set the LOG/LINEAR switch to LINEAR, and set LINEAR SENSITIVITY to 20 mV per division. Make any fine adjustment of the AMPL CAL which is necessary to bring the trace to the fifth graticule line (5 x 20 mV = 100 mV).

(8) TRACKING ADJUSTMENT

a. Return the LOG/LINEAR switch to 10 dB LOG. Set the LOG REF LEVEL to -10 dBV, and set the SCAN WIDTH to ZERO. Reduce the BANDWIDTH to 10 Hz (50 Hz on 8552A). Adjust TRACK ADJ to bring the trace as high as possible on the screen.

b. Set the LOG/LINEAR switch to 2 dB LOG (or LINEAR) and repeat the peaking procedure, then return to 10 dB LOG.

Figure 3-2. Operational Adjustments (1 of 3)

OPERATIONAL ADJUSTMENTS

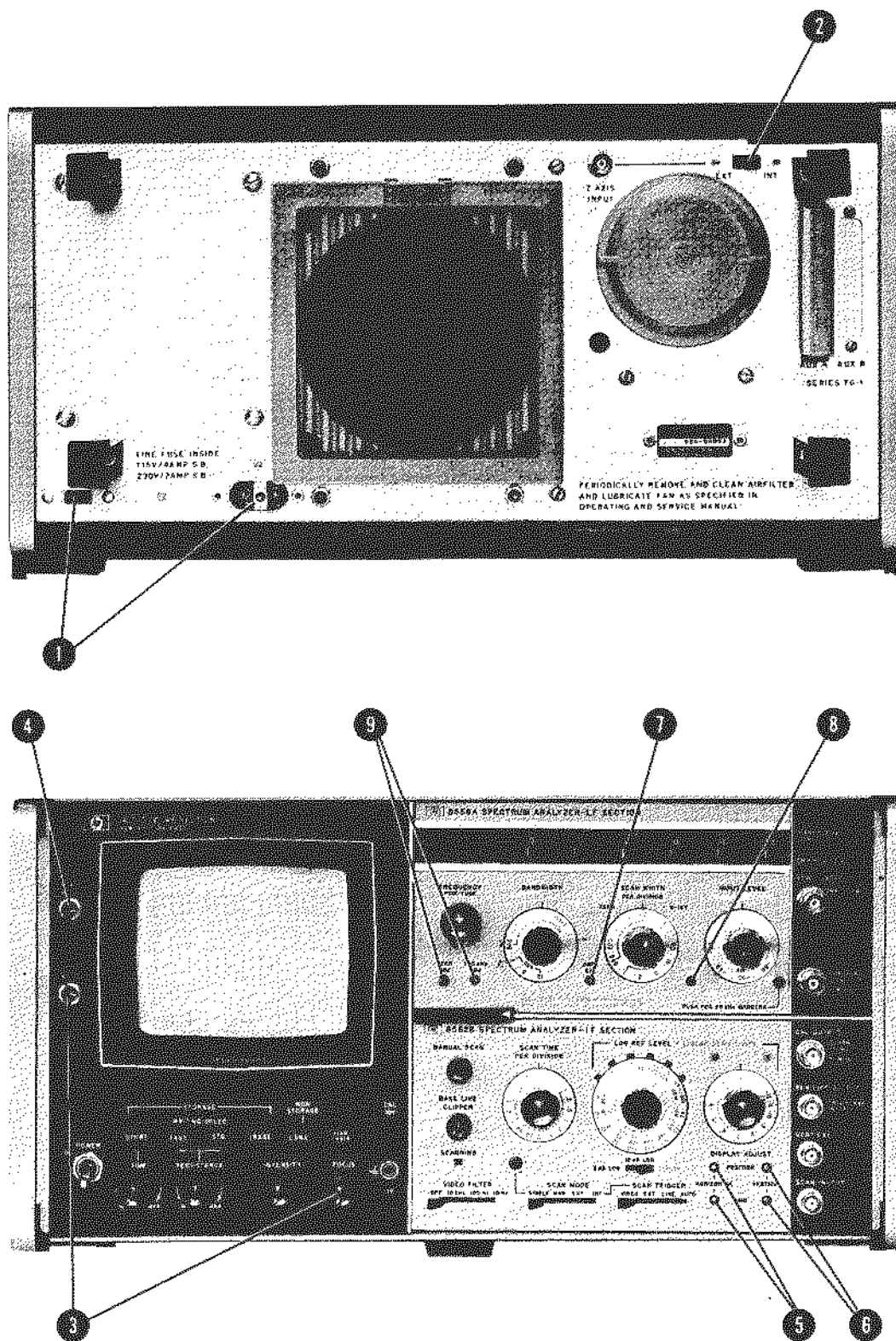

Figure 3-2. Operational Adjustments (3 of 3)

OPERATIONAL ADJUSTMENTS

(9) FREQUENCY CALIBRATION

a. Disconnect TRACKING GEN OUT from INPUT and set the controls as follows:

FREQUENCY 0 kHz
RANGE 0-30 kHz
FINE TUNE Centered
BANDWIDTH..... 300 Hz
SCAN WIDTH PER DIVISION
PER DIVISION 1 kHz
20 kHz MARKERS In
SCAN TIME PER DIVISION 50 MILLISECONDS
VIDEO FILTER OFF

b. Center LO feedthrough signal, at CENTER FREQUENCY graticule on the display, with ZERO ADJ. The dial should be accurately set to 0 kHz.

NOTE

If using an 8552A IF Section and ZERO ADJ will not zero the LO feedthrough, see paragraph 5-30 in Section VI.

c. Set RANGE to 0-300 kHz, and slowly tune FREQUENCY to 300 kHz, counting 20 kHz markers as they pass the CENTER FREQUENCY graticule on the display. Center the fifteenth marker (300 kHz) on the CENTER FREQUENCY graticule.

d. Adjust 300 kHz ADJ so that the dial reads 300 kHz when the fifteenth marker is centered.

e. Repeat steps 9b through 9d until no further adjustment is necessary.

NOTE

Some minor readjustment of tracking adjustment and frequency calibration controls may be necessary from time to time for narrowband operation.

impedance (600 ohms or 50 ohms). The input should then be terminated with a feedthrough termination for the impedance selected.

3-34. For voltage measurements, the dBm/dBV switch can be set to dBV for a log display, or the LOG/LINEAR switch can be set to LINEAR for a linear display. If no feedthrough termination is used, the spectrum analyzer will display the open circuit voltage. If a feedthrough termination is used, the voltage displayed will be that developed across the impedance of the termination.

3-35. The next step is to insure that the spectrum analyzer is operating linearly. That is, that all spectral components displayed are present at the input and not generated in the spectrum analyzer. This is readily accomplished: read the amplitude of the largest signal on the CRT, and set the INPUT LEVEL control to the setting nearest this amplitude. For example, if the largest signal on the display reads -13 dBV, the INPUT LEVEL control would be set to -10 dBm/dBV.

3-36. Now set the LOG REF LEVEL or LINEAR SENSITIVITY controls to give the desired display. One convenient way to set the LOG REF LEVEL is to set the -10 dBm/dBV position under the right hand indicator light. The -60 dBm/dBV position will then fall under the left hand indicator light. In this position, setting the INPUT LEVEL control to the amplitude of the largest signal will bring that signal to the top of the CRT. This gives the widest possible display dynamic range for signals between -60 dBm/dBV and -10 dBm/dBV.

3-37. Using the Tracking Generator

3-38. The tracking generator is a flat signal source whose output frequency precisely, tracks the spectrum analyzer's tuning frequency. This output can be used as a source to test devices for frequency response. Also, by measuring the frequency of the tracking generator's output with a frequency counter, the frequency of signals appearing on the spectrum analyzer display can be precisely determined.

3-39. Frequency Response Measurements. The frequency scan of the spectrum analyzer is set in much the same way as described under paragraph 3-26. The tracking generator's output frequency is determined by the spectrum analyzer's scan. If a device is being tested from 0-20 kHz, it is only necessary to set the spectrum analyzer to scan 0-20 kHz using the 0-10f mode.

3-40. The device under test will be connected in the signal path between the TRACKING GEN OUT and the

INPUT. Some consideration must be given to the input and output impedances of the test device. If the device has a 600 ohm input impedance, the tracking generator can be connected directly to the device. The 50-ohm Tracking Generator Shunt supplied with the 8556A should be used between the tracking generator and the test device for devices with a 50-ohm input impedance.

3-41. The output of the device should be terminated in its characteristic impedance. 50 ohm or 600 ohm devices can be terminated using the feedthrough terminations, and high impedance devices can be connected directly to the spectrum analyzer INPUT (see Figure 3-3). Measure devices which have a different impedance by using a simple resistive termination.

3-42. The tracking generator output level is 100 mV (-20 dBV) open circuit in the CAL position. This amounts to 50 mV (-26 dBV) across 600 ohms. If the 50 ohm shunt is used, the output will be 4.17 mV or -34.6 dBm into 50 ohms. The output level increases as TRACKING GEN LEVEL is turned clockwise from the CAL position.

3-43. System Calibration. The TRACKING GEN OUT should be connected through any necessary terminations to the spectrum analyzer INPUT. The TRACKING GEN LEVEL can then be adjusted to bring the trace to the top graticule line, thus providing a convenient reference. The INPUT LEVEL control should be set to -20 dBm/dBV and the LOG REF LEVEL set to 0 dBm/dBV for maximum measurement range on passive devices. (Use the dBm scale for 50 ohm devices and the dBV scale for 600 ohm devices.) 3-44. Insert the test device in the circuit, and its frequency response will be displayed directly on the CRT. Insertion loss can be read directly from the dB scale on the CRT.

3-45. Testing Amplifiers. When measuring amplifier frequency response, some provision must be made for the gain of the amplifier to prevent damage to the spectrum analyzer. A step attenuator should be added to the test setup to decrease the tracking generator level by a known amount (see Figure 3-4).

3-46. Set the attenuator to 0 dB and perform the calibration procedure described under System Calibration. Then the attenuation should be increased by an amount greater than the gain of the amplifier under test. The gain of the amplifier will be the sum of the attenuator setting and the dB reading from the CRT graticule at any point. (Remember, this is a negative number on the graticule.) For example, the spectrum analyzer is calibrated for a reference at the top of the CRT. Now a test

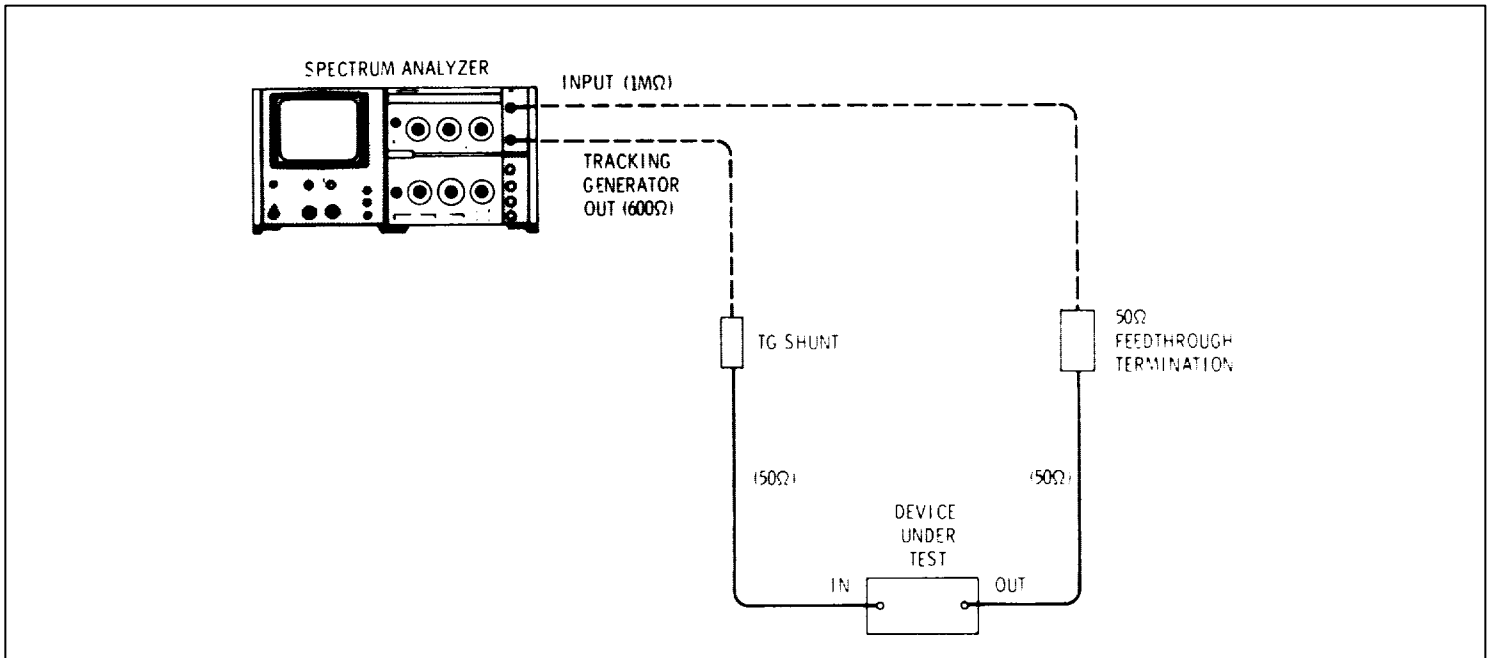

Figure 3-3. Typical Frequency Response Measurement (in 50 Ohms)

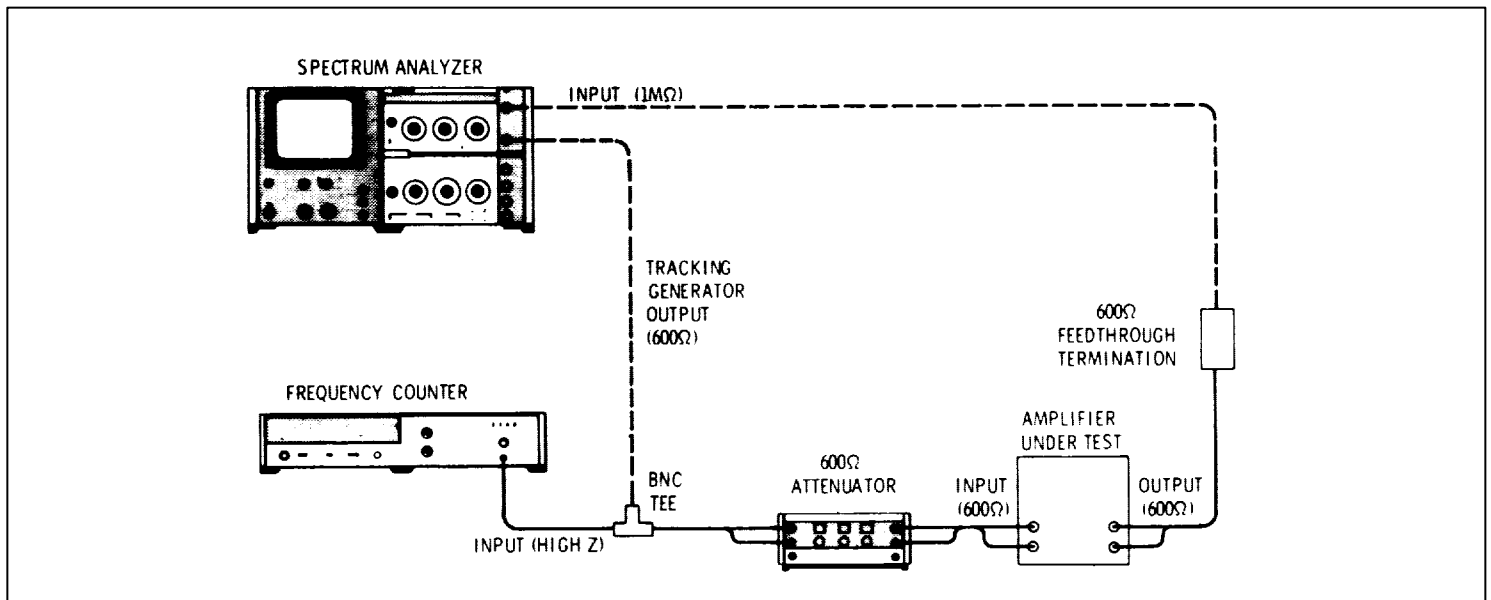

Figure 3-4. Typical Amplifier Frequency Response Measurement (in 600 Ohms) Using a Frequency Counter

amplifier is inserted, and the attenuator is set to 50 dB. If the amplifier response curve is at the -7 dB graticule line, the gain is 43 dB (50 dB 7 dB).

3-47. Important Considerations. When using the tracking generator for swept response measurements, the spectrum analyzer BANDWIDTH and DISPLAY UNCAL light take on somewhat different significance. The BANDWIDTH setting mainly affects the average noise level and has only a secondary effect on resolution. Narrowing the BANDWIDTH improves dynamic range, but requires slower sweep rates. The DISPLAY UNCAL light in most cases will not apply. The best procedure in swept response measurements is to slow the scan rate until the display amplitude remains constant with changes in SCAN TIME PER DIVISION. At this point, the scan is the proper rate to satisfy the requirements of both the spectrum analyzer and the device under test.

3-48. Spurious responses are not displayed on the CRT due to the tracking signal source and receiver. Therefore, measurements may be made over a dynamic range limited only by gain compression as an upper limit and system noise as a lower limit.

3-49. Devices, such as filters, which may have attenuation greater than 100 dB can be measured. The response can be traced out on the CRT in two 70 dB segments, and the results can be photographed to give a composite picture.

3-50. Precise Frequency Measurements. It may be desired to measure the frequency of a low level signal which is close to a higher level signal. First, confirm that TRACK ADJ is correctly adjusted (see Figure 3-2), then connect a low frequency counter to the tracking generator's output. Using the MANUAL SCAN mode, scan the spectrum analyzer until you reach the peak of the signal response. The frequency displayed on the counter is the frequency of the signal. Resolution of 1 Hz is possible using narrow scan widths and bandwidths on the spectrum analyzer. (The counter gate time for this resolution is 1 second.)

3-51. This same method may be applied to the measurement of points on a frequency response curve. Use a high impedance counter and connect it to the tracking generator's output on a tee with the test device (see Figure 3-4). Then manually scan to a point of interest on the response curve and read the frequency. This method is useful when measuring the 3 dB or 6 dB bandwidth of a filter, discontinuities in a response characteristic, or identifying spurious modes on a device.

3-52. Variable Persistence and Storage Functions

3-53. With the 141T Display Section the operator can set trace persistence for a bright, steady trace that does not flicker, even on the slow sweeps required for narrow band analysis. The variable persistence also permits the display of low repetition rate pulses without flickering and, using the longest persistence, intermittent signals can be captured and displayed. The storage capability allows side-by-side comparison of changing signals.

3-54. Persistence and Intensity. The persistence and intensity determine how long a written signal will be visible. Specifically, PERSISTENCE controls the rate at which a signal is erased and INTENSITY controls the trace brightness as the signal is written. With a given PERSISTENCE setting, the actual time of trace visibility can be increased by greater INTENSITY. Since the PERSISTENCE control sets the rate of erasing a written signal, it follows that a brighter trace will require more time to be erased. Conversely, a display of low intensity will disappear more rapidly. The same principle applies to a stored display of high and low intensity.

CAUTION

Excessive INTENSITY will damage the CRT storage mesh. The INTENSITY setting for any sweep speed should just eliminate trace blooming with minimum PERSISTENCE setting.

3-55. Storage. The storage controls select the storage mode in which the CRT functions. In ERASE, STORE and WRITING SPEED are disconnected and all written signals are removed from the CRT. The STORE selector disconnects the WRITING SPEED AND ERASE functions and implements signal retention at reduced intensity. In the STORE mode, PERSISTENCE and INTENSITY have no function.

3-56. Writing Speed. In the FAST mode, the rate of erasing a written display is decreased. Since the erasing rate is decreased, the entire screen becomes illuminated more rapidly and the display is obscured. The effective persistence and storage time are considerably reduced.

3-57. Photographic Techniques

3-58. Excellent signal photography is possible when the Spectrum Analyzer is used with an oscilloscope camera and when proper techniques are employed. Both the HP 196B and the 197A Oscilloscope Cameras attach directly to the analyzer's CRT bezel without adapters. Both cameras also have an Ultra-Violet light source that causes a

Model 8556A Operation

uniform glow of the CRT phosphor. This gives the finished photograph a grey background that contrasts sharply with the white trace and the black graticule lines. Ultra-Violet illumination is normally used only when the CRT is of the non-

storage and fixed persistence type (140T Display Section). For a storage or variable persistence CRT (141T Display Section), a uniform gray background is obtained by simply taking the , photograph in STORE rather than in VIEW.

SECTION IV PERFORMANCE TESTS

4-1. INTRODUCTION

4-2. This section provides instructions for performance testing the Model 8556A Spectrum Analyzer LF Section. Front panel checks for routine inspection are given in Table 4-1. The performance tests verify that the instrument meets the specifications listed in Table 1-1.

4-3. Perform the tests in procedural order with the test equipment called for, or with its equivalent. During the tests, all circuit boards, shields, covers and attaching hardware must be in place, and the LF and IF Sections must be installed in the Display Section. Allow the analyzer to warm up at least one hour before performing the tests.

4-4. EQUIPMENT REQUIRED

4-5. Test equipment and test equipment accessories for the performance tests (designated "P" in the "use" column) are specified in Tables 1-4 and 1-5. Equipment other than that listed may be used providing that it meets or exceeds the minimum specifications listed in the tables.

4-6. OPERATIONAL ADJUSTMENTS

4-7. Before proceeding to the performance tests, perform the operational adjustments specified in Figure 3-2 (in Section III). These adjustments correct for minor differences between units and ensure that the LF Section, IF Section and Display Section are properly calibrated.

4-8. FRONT PANEL CHECKS

4-9. The front panel checks provide a quick method for verifying that the LF Section is operating correctly. After performing the operational adjustments described in Figure 3-2, set the analyzer's controls as specified in Table 4-1 and perform the checks.

4-10. TEST SEQUENCE

4-11. The performance tests are suitable for incoming inspection, troubleshooting, and preventive maintenance. A test card for recording data is included at the back of this section.

4-12. Perform the tests in the following order:

- a. Allow analyzer to warm up one hour.
- b. Perform operational adjustments listed in Figure 3-2.
- c. Perform front panel checks listed in Table 4-1.
- d. Perform the performance tests in the order given.

4-13. Each test is arranged so that the specification is written as it appears in Table 1-1. Next is a description of the test that includes any special instructions. Each test that requires test equipment has a test setup drawing and a list of required equipment.

Table 4-1. Front Panel Checks

Function	Procedure	Result
Calibration	1) Perform operational adjustments specified in Section III (Figure 3-2), then set analyzer as follows: RANGE0-300 kHz FREQUENCY 0 kHz BANDWIDTH 10 kHz SCAN WIDTH PER DIVISION PER DIVISION 20 kHz INPUT LEVEL-30 dBm/dBV dBm/dBV6002 dBm 20 kHz MARKERS Out SCAN TIME PER DIVISION 50 MILLISECONDS LOG/LINEAR 10 dB LOG LOG REF LEVEL-20 dBm/dBV VIDEO FILTER OFF SCAN MODEINT SCAN TRIGGERAUTO	1) Analyzer calibrates normally.
BASE LINE CLIPPER	2) Turn BASE LINE CLIPPER full clockwise. 3) Turn BASE LINE CLIPPER full counterclockwise.	2) At least bottom two divisions blank on CRT.
Scan	4) Turn SCAN TIME PER DIVISION through its range. 5) Return SCAN TIME PER DIVISION to 50 MILLISECONDS. Center LO feedthrough on CRT with FREQUENCY.	4) Scan occurs in all positions.
BANDWIDTH & SCAN WIDTH PER DIVISION	6) Reduce SCAN WIDTH PER DIVISION to 20 Hz, reducing BANDWIDTH to maintain LO feedthrough about 2 divisions wide. Reduce SCAN TIME PER DIVISION to keep DISPLAY UNCAL lamp unlit; keep signal centered with FREQUENCY and FINE TUNE.	6) LO feedthrough narrows as BANDWIDTH is reduced and widens as SCAN WIDTH PER DIVISION is reduced.
SCAN WIDTH 0-10f	7) Set SCAN WIDTH to 0-10f, PER DIVISION to 20 kHz, BANDWIDTH to 1 kHz, and SCAN TIME PER DIVISION to 50 MILLISECONDS. 8) Depress 20 kHz MARKERS switch. about every major	7) LO feedthrough appears at left graticule on CRT. 8) Markers appear at
DISPLAY UNCAL light	9) Increase SCAN TIME PER DIVISION to 20 MILLISECONDS.	9) DISPLAY UNCAL light illuminates.

PERFORMANCE TESTS

4-14. TRACKING GENERATOR AMPLITUDE

SPECIFICATIONS:

Amplitude Range: Continuously variable from 100 mV rms to greater than 3 V rms into an open circuit.

Amplitude Accuracy: With TRACKING GEN LEVEL in CAL position, output level at 100 kHz is 100 Mv ± 0.3 dB into an open circuit.

Frequency Response: ±0.25 dB, 50 Hz to 300 kHz.

DESCRIPTION: An AC Voltmeter is used to measure the amplitude range and accuracy and the frequency response of the tracking generator.

EQUIPMENT:

AC Voltmeter	HP 400EL
Frequency Counter	HP 5327C
24" BNC Cable Assy.....	HP 11086A

PROCEDURE:

1. Connect equipment as shown in Figure 4-1, connecting AC Voltmeter directly to TRACKING GEN OUT with 24" BNC cable.

2. Set analyzer as follows:

RANGE	0-300 kHz
FREQUENCY	100 kHz
SCAN WIDTH	ZERO
TRACKING GEN LEVEL	CAL 100 mV

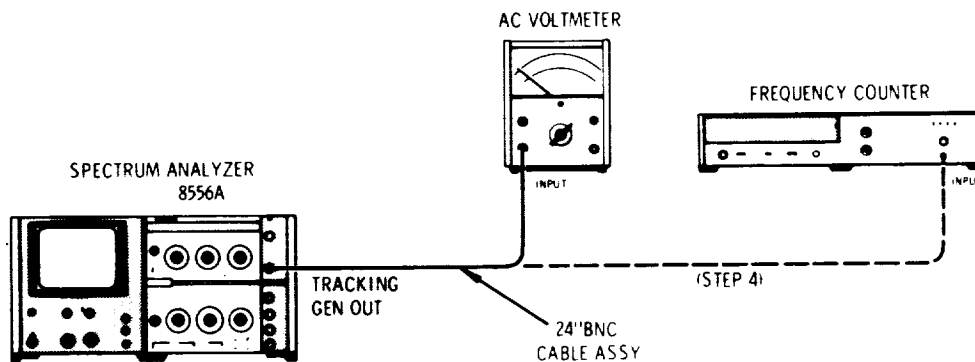

Figure 4-1. Tracking Generator Test Setup

3. Set voltmeter to measure 100 mV. It should read 100 mV ±3.5 mV.

Amplitude Accuracy: 96.5 ____ 103.5 mV

4. Disconnect BNC cable from voltmeter and connect it to Frequency Counter. Set TRACKING GEN LEVEL fully clockwise, and tune FREQUENCY and FINE TUNE for a 50 Hz reading on counter.

PERFORMANCE TESTS

4-14. TRACKING GENERATOR AMPLITUDE (cont'd)

5. Set voltmeter to measure 3 volts. Disconnect BNC cable from counter and re-connect it to voltmeter. Voltmeter should read $\geq 3V$:

Amplitude Range: 3V_____

6. Reset TRACKING GEN LEVEL to CAL 100 mV, and reset voltmeter to measure 100 mV.

7. Slowly tune FREQUENCY from 50 Hz (set in step 5) to 300 kHz. Voltmeter should indicate a maximum variation of 0.5 dB (± 0.25 dB) through entire range:

Frequency Response: _____0.5 dB

4-15. MARKER ACCURACY

SPECIFICATION: RF markers every 20 kHz accurate to within $\pm 0.01\%$.

DESCRIPTION: The tracking generator is peaked to ensure that it is accurately tracking the analyzer tuning, and a frequency counter is connected to TRACKING GEN OUTPUT. Marker accuracy is tested using MANUAL SCAN (with 8552B IF Section) or ZERO SCAN (with 8552A IF Section) to tune the analyzer to the markers.

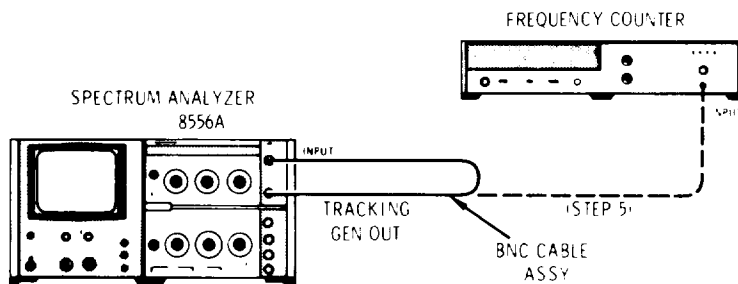

Figure 4-2. Marker Accuracy Test Setup

EQUIPMENT:

- Frequency Counter HP 5327C
- BNC Cable Assembly..... HP 10503A
- Tuning Tool (or small screwdriver) HP 8710-1010

PROCEDURE:

1. Connect equipment as shown in Figure 4-2, connecting TRACKING GEN OUT to analyzer INPUT with BNC cable.

PERFORMANCE TESTS

4-15. MARKER ACCURACY (cont'd)

2. Set analyzer as follows:

RANGE.....0-300 kHz
 FREQUENCY300 kHz
 FINE TUNE Centered
 BANDWIDTH..... 10 Hz (8552B) 50 Hz (8552A)
 SCAN WIDTH.....ZERO
 PER DIVISION 1 kHz
 TRACKING GEN LEVEL..... Cal 100 mV
 INPUT LEVEL.....-20 dBm/dBV
 dBm/dBV..... dBV
 20 kHz MARKERS Out
 SCAN TIME PER DIVISION 5 MILLISECONDS
 LOG REF LEVEL.....-10 dBV
 LOG/LINEAR 10 dB LOG
 VIDEO FILTER..... OFF
 SCAN MODE.....INT
 SCAN TRIGGER.....AUTO
 BASE LINE CLIPPER..... ccw

3. Using tuning tool or small screwdriver, adjust TRACK ADJ to peak trace as high as possible on CRT display.
4. Set LOG/LINEAR to LINEAR and LINEAR SENSITIVITY to 20 mV/DIV and, again, peak trace.
5. Disconnect TRACKING GEN OUT from analyzer INPUT; connect TRACKING GEN OUT to Frequency Counter (if necessary, increase TRACKING GEN LEVEL to get reading on counter).
6. Depress 20 kHz MARKERS switch, set BANDWIDTH to 300 Hz, and set SCAN WIDTH to PER DIVISION. Set LINEAR SENSITIVITY to 2 mV/DIV, SCAN TIME PER DIVISION to 50 MILLISECONDS, and center 300 kHz marker on CRT display with FREQUENCY and FINE TUNE.
7. Set SCAN WIDTH PER DIVISION to 20 Hz, BANDWIDTH to 10 Hz, and SCAN MODE to MAN. Use MANUAL SCAN knob to set dot on CRT to peak of marker. Frequency Counter should read 300 kHz \pm 30 Hz:

Marker Accuracy: 299,970 ____ 300,030 Hz

NOTE

With 8552A IF Section, perform test with SCAN WIDTH set to ZERO and BANDWIDTH set to 50 Hz; peak trace with FINE TUNE to get reading.

8. Set SCAN MODE to INT, and tune FREQUENCY down to next marker (should be at 280 kHz).
9. Set SCAN MODE to MAN and use MANUAL SCAN knob to set dot on CRT to peak of marker. Counter should read 280 kHz \pm 28 Hz:

Marker Accuracy: 279,972 ____ 280,028 Hz

PERFORMANCE TESTS

4-16. SCAN WIDTH ACCURACY

SPECIFICATION:

With 8552B IF Section:

Frequency error between any two points on the display is less than +3% of the indicated frequency separation.

With 8552A IF Section:

Frequency error between any two points on the display is less than $\pm 5\%$ of the indicated frequency separation.

DESCRIPTION: Internal 20 kHz markers are used to test scan width accuracy on the CRT display.

PROCEDURE:

1. Set analyzer as follows:

RANGE0-300 kHz
 FREQUENCY 100 kHz
 FINE TUNE Centered
 BANDWIDTH 1 kHz
 SCAN WIDTH PER DIVISION
 PER DIVISION 20 kHz
 INPUT LEVEL.....-20 dBm/dBV
 dBm/dBV..... dBV
 20 kHz MARKERS In
 SCAN TIME PER DIVISION 50 MILLISECONDS
 LOG REF LEVEL.....-10 dBV
 LOG/LINEAR..... 10 dB LOG
 VIDEO FILTER..... OFF
 SCAN MODE.....INT
 SCAN TRIGGER.....AUTO
 BASE LINE CLIPPER..... ccw

2. Note that a 20 kHz marker appears at about every major division on the CRT display. Tune FREQUENCY and FINE TUNE to center a marker on the -4 graticule line (see Figure 4-3).
3. Measure amount of error, in divisions, that the marker deviates from the +4 graticule line. Marker should appear on the +4 graticule line plus or minus the specified tolerance (for IF Section being used):

With 8552B IF Section, +0.24 major divisions: +3.76 \pm 4.24

With 8552A IF Section, ± 0.4 major divisions: +3.60 \pm 4.40

4. Set BANDWIDTH to 300 Hz, SCAN TIME PER DIVISION to 0.1 SECONDS, and SCAN WIDTH PER DIVISION to 5 kHz. Turn FREQUENCY and FINE TUNE to center a marker on the -4 graticule line.

5. Measure amount of error, in divisions, that the marker deviates from the +4 graticule line. Marker should appear on the +4 line plus or minus the specified tolerance:

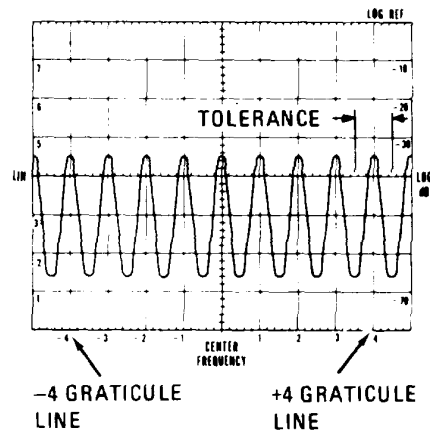

Figure 4-3. Scan Width Accuracy Display

PERFORMANCE TESTS

4-16. SCAN WIDTH ACCURACY (cont'd)

With 8552B IF Section, ± 0.24 major divisions: +3.76 ____ +4.24

With 8552A IF Section, ± 0.4 major divisions: +3.60 ____ +4.40

NOTE

If 8556A appears to be out of tolerance, re-check scan width accuracy at 160, 220, and 280 kHz. If 8556A scan width accuracy is within tolerance at any frequency, check IF Section scan time accuracy.

4-17. CENTER FREQUENCY ACCURACY

SPECIFICATION: After 1 hour warmup, zero and 300 kHz adjustments, and with the FINE TUNE centered, the dial indicates the display center frequency within the following specifications:

With 8552B IF Section:

0-30 kHz Range: ± 500 Hz

0-300 kHz Range: ± 3 kHz

With 8552A IF Section:

0-30 kHz Range: ± 1 kHz

0-300 kHz Range: ± 5 kHz

DESCRIPTION: Dial accuracy is tested using internal 20 kHz markers. Any error between the CENTER FREQUENCY dial reading and the marker frequency is measured on the CRT display.

PROCEDURE:

1. Set analyzer as follows:

RANGE	0-300 kHz
FREQUENCY	20 kHz
FINE TUNE	Centered
BANDWIDTH	300 Hz
SCAN WIDTH	PER DIVISION
PER DIVISION	kHz
INPUT LEVEL	-20 dBm/dBV
dBm/dBV	dBV
20 kHz MARKERS	In
SCAN TIME PER DIVISION	50 MILLISECONDS
LOG REF LEVEL	-10 dBV
LOG/LINEAR	10 dB LOG
VIDEO FILTER	OFF
SCAN MODE	INT
SCAN TRIGGER	AUTO
BASE LINE CLIPPER	ccw

2. Using FREQUENCY control, center the dial marker on the CENTER FREQUENCY dial every 20 kHz from 20 kHz to 300 kHz (for example, 40 kHz, 60 kHz, 80 kHz, etc.). At each 20 kHz point, a 20 kHz marker should appear at CENTER FREQUENCY graticule on the CRT within the tolerance shown below:

With 8552B IF Section: -3 ____ +3 divisions

With 8552A IF Section: -5 ____ +5 divisions

PERFORMANCE TESTS

4-17. CENTER FREQUENCY ACCURACY (cont'd)

3. Switch SCAN WIDTH PER DIVISION to 500 Hz, and switch RANGE to 0-30 kHz. Tune FREQUENCY to 0 kHz and adjust ZERO ADJ to center LO feedthrough on CENTER FREQUENCY graticule. Then tune FREQUENCY to center the dial marker on the CENTER FREQUENCY dial at 20 kHz. The 20 kHz marker should appear at CENTER FREQUENCY graticule on CRT plus or minus the specified tolerance (in major divisions):

With 8552B IF Section: -1 ____ +1 divisions

With 8552A IF Section: -2 ____ +2 divisions

4-18. FREQUENCY RESPONSE

SPECIFICATION: Log: ± 0.2 dB; Linear: 2.3%.

DESCRIPTION: The tracking generator's output is calibrated with an AC Voltmeter and used to test the analyzer's frequency response. The analyzer (with the tracking generator) is set to 20 Hz (if using an 8552B IF Section) or 100 Hz (if using an 8552A IF Section). The analyzer is then tuned slowly to 300 kHz. Any variations in frequency response are read on a Digital Voltmeter connected to VERTICAL OUTPUT.

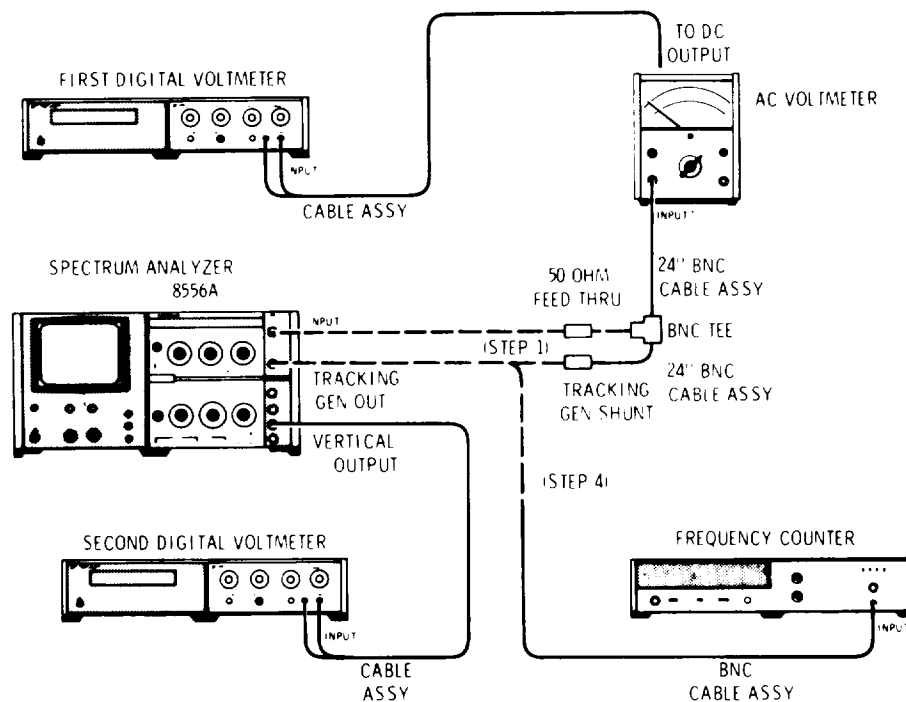

Figure 4-4. Frequency Response Test Setup

PERFORMANCE TESTS

4-18. FREQUENCY RESPONSE (cont'd)

EQUIPMENT:

AC Voltmeter	HP 400EL
Digital Voltmeter (2)	HP 3480B/3484A, Option 042
Frequency Counter	HP 5327C
BNC Cable Assy.....	HP 10503A
BNC Tee.....	HP 1250-0781
Cable Assy.....	HP 11001A
Cable Assy.....	HP 11000A
Tracking Gen Shunt	HP 11660A
50 Ohm Feed Thru Termination.....	HP 11048B
24" BNC Cable Assy (2)	HP 11086A
Tuning Tool (or small screwdriver).....	HP 8710-1010

1. Connect equipment as shown in Figure 4-4, connecting TRACKING GEN OUT to analyzer INPUT through the Tracking Gen Shunt, BNC Tee, 24" BNC Cable Assembly, and the 50 Ohm Feed Thru Termination. Connect AC Voltmeter to BNC Tee at feed thru with a 24" BNC Cable Assembly; connect first Digital Voltmeter to DC OUTPUT on rear panel of AC Voltmeter. Connect second Digital Voltmeter to VERTICAL OUTPUT on IF Section.

2. Set analyzer as follows:

RANGE .-	0-30 kHz
FREQUENCY	5 kHz
FINE TUNE	Centered
BANDWIDTH	10 Hz (8552B) 50 Hz (8552A)
SCAN WIDTH	ZERO
INPUT LEVEL.....	-40 dBm/dBv
TRACKING GEN LEVEL	12 o'clock
20 kHz MARKERS	Out
SCAN TIME PER DIVISION	5 MILLISECONDS
LOG/LINEAR.....	LINEAR
LINEAR SENSITIVITY	10 mV/DIV
VIDEO FILTER.....	100 Hz
SCAN MODE.....	INT
SCAN TRIGGER.....	AUTO
BASE LINE CLIPPER.....	ccw

3. Using tuning tool or small screwdriver, adjust TRACK ADJ to peak trace as high as possible on CRT display.
4. Disconnect Tracking Gen Shunt from TRACKING GEN OUT and connect Frequency Counter to TRACKING GEN OUT. Set Frequency Counter to measure 100 Hz. Tune FREQUENCY and FINE tune down until counter reads 20 Hz (with 8552B) or 100 Hz (with 8552A). Disconnect counter and re-connect Tracking Gen Shunt to TRACKING GEN OUT.
5. Set AC Voltmeter to measure 30 mV full scale. Set first Digital Voltmeter (connected to AC Voltmeter) to measure 1.000 volts. Adjust TRACKING GEN LEVEL for a 1.000 V reference on first Digital Voltmeter.
6. Set second Digital Voltmeter (connected to analyzer VERTICAL OUTPUT) to measure 1.000 volts. Adjust LINEAR SENSITIVITY for a 700.0 mV reference on second Digital Voltmeter.

PERFORMANCE TESTS

4-18. FREQUENCY RESPONSE (cont'd)

7. Tune FREQUENCY control to frequencies noted below. At each frequency, re-adjust TRACKING GEN LEVEL for a 1.000 volt reading on first Digital Voltmeter, then note reading on second Digital Voltmeter (don't re-adjust LINEAR SENSITIVITY).

Frequency	Reading	
1 kHz	_____	mV
3 kHz	_____	mV
5 kHz	_____	mV
10 kHz	_____	mV
20 kHz	_____	mV
30 kHz	_____	mV

Difference between the maximum and minimum readings shall not exceed 32.2 mV.

8. Set RANGE to 0-300 kHz and tune FREQUENCY control to 5 kHz. Again, re-adjust TRACKING GEN LEVEL for a 1.000 volt reading on first Digital Voltmeter. Adjust LINEAR SENSITIVITY for a 700 mV reference on second Digital Voltmeter.

9. Use instructions in 7 above for frequencies noted below.

Frequency	Reading	
50 kHz	_____	mV
100 kHz	_____	mV
150 kHz	_____	mV
200 kHz	_____	mV
250 kHz	_____	mV
300 kHz	_____	mV

Difference between the maximum and minimum readings shall not exceed 32.2 mV.

4-19. AVERAGE NOISE LEVEL

SPECIFICATION: Specified with a 600 ohm or less source impedance and INPUT LEVEL at -60 dBm/dBV.

Mode	1 kHz IF Bandwidth	10 Hz IF Bandwidth
dBm - 50 Ω	< -122 dBm (180 nV)	< -142 dBm (18 nV)
dBm- 600 Ω	< -130 dBm (250 nV)	< -150 dBm (25 nV)
dBV	< -132 dBV (250 nV)	< -152 dBV (25 nV)
Linear	< 400 nV	< 40 nV

DESCRIPTION: Average noise level is observed on the analyzer's calibrated CRT display with no signal input and the analyzer INPUT terminated in 600 ohms.

NOTE

The 10 Hz bandwidth specification can be checked only when using an 8552B IF Section.

EQUIPMENT:

600 Ohm Feed Thru TerminationHP 11095A

PROCEDURE:

- Connect 600 Ohm Feed Thru Termination to INPUT. Set the analyzer as follows:
 - RANGE 0-30 kHz
 - FREQUENCY 7 kHz
 - FINE TUNE Centered
 - BANDWIDTH..... kHz

PERFORMANCE TESTS

4-19. AVERAGE NOISE LEVEL (cont'd)

SCAN WIDTHZERO
 INPUT LEVEL.....-60 dBm/dBV
 20 kHz MARKERS Out
 SCAN TIME PER DIVISION 50 MILLISECONDS
 LOG/LINEAR LINEAR
 LINEAR SENSITIVITY0.1 V/DIV
 Vernier ccw
 VIDEO FILTER..... 10 Hz (with 8552B), 100 Hz (with 8552A)
 SCAN MODE.....INT
 SCAN TRIGGER.....AUTO
 BASE LINE CLIPPER ccw

- Observe average noise level on CRT display. It should be less than 400 nV (the 4 graticule line on the CRT represents 400 nV). Tune the analyzer to 300 kHz using FREQUENCY and RANGE controls; the average noise level should be less than 400 nV throughout the range:

LINEAR noise level: ____ 400 nV

NOTE

Average noise level is read at the mid-point of the noise on the CRT display (see Figure 4-5).

- Set LOG/LINEAR to 10 dB LOG. In turn, set dBm/dBV switch to 50 Ω dBm, dBV, and 600 Ω dBm; at each setting, tune the analyzer from 7 kHz to 300 kHz and read the average noise level. It should be as specified below:

50 Ω dBm noise level, < -122 dBm: ____ -122 dBm
 dBV noise level, < -132 dBV: ____ -132 dBV
 600 Ω dBm noise level, < -130 dBV: ____ -130 dBV

- If using an 8552B IF Section, set BANDWIDTH to 10 Hz and check average noise level from 100 Hz to 300 kHz in all four modes. It should be as specified below:

LINEAR noise level, < 40 nV: ____ 40 nV
 50 Ω dBm noise level, < -142 dBm: ____ -142 dBm
 dBV noise level, < -152 dBV: ____ -152 dBV
 600 Ω dBm noise level, < -150 dBm: ____ -150 dBm

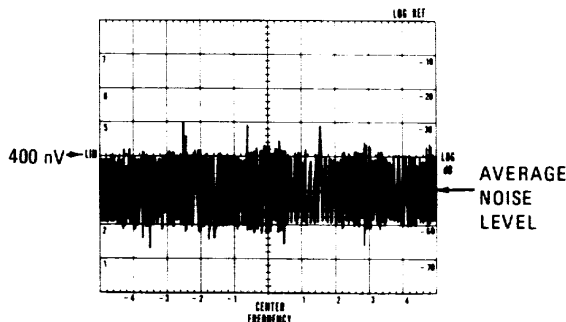

Figure 4-5. Average Noise Level Display

PERFORMANCE TESTS

4-20. RESIDUAL RESPONSES

SPECIFICATION: (No signal present at INPUT.) With the INPUT LEVEL AT -60 dBm/dBV and the input terminated with 600 ohms or less, all line related residual responses from 0 to 500 Hz are below -120 dBm/dBV. All other residual responses are below -130 dBm/dBV.

DESCRIPTION: Residual responses are signals that appear on the display with no input signal. To measure them, a reference is selected so that -120 and -130 dBm/dBV are easily determined, and the display is searched for signals appearing above this reference.

EQUIPMENT:

50 Ohm Feed Thru Termination

HP 11048B

1. Connect 50 Ohm Feed Thru Termination to INPUT and set analyzer as follows:

RANGE 0-30 kHz
 FREQUENCY 0 kHz
 FINE TUNE Centered
 BANDWIDTH..... 100 Hz
 SCAN WIDTH..... PER DIVISION
 PER DIVISION 100 Hz
 INPUT LEVEL.....-60 dBm/dBV
 dBm/dBV.....502 dBm
 20 kHz MARKERS Out
 SCAN TIME PER DIVISION..... 50 MILLISECONDS
 LOG/LINEAR..... 10 dB LOG
 LOG REF LEVEL.....-80 dBm/dBV
 Vernier ccw
 BASE LINE CLIPPER..... ccw
 VIDEO FILTER..... OFF
 SCAN MODEINT
 SCAN TRIGGER.....AUTO

NOTE

Instruments that radiate magnetic spurs (such as counters, power supplies, etc.) should not be operating near 8556A during this test.

2. Using FREQUENCY and FINE TUNE, tune LO feedthrough (0 Hz) to far left graticule line on CRT display (see Figure 4-6).
3. Set BANDWIDTH to 10 Hz (with 8552B IF Section) or 50 Hz (with 8552A IF Section). Set SCAN TIME PER DIVISION to 2 SECONDS.
4. Measure residual responses from the point that the skirt of the LO feedthrough crosses the -40 dB graticule on the CRT (-120 dBm) to CENTER FREQUENCY graticule (500 Hz). They should be below -120 dBm:

Line Related Residual Responses: _____ -120 dBm

NOTE

Check that peak of LO feedthrough is below -80 dBm. If it is not, null it (see Section III) and re-check line related residual responses.

PERFORMANCE TESTS

4-20. RESIDUAL RESPONSES (cont'd)

5. Check that any residual responses from 500 Hz (CENTER FREQUENCY graticule) to 1 kHz (far right graticule line) are below -130 dBm:

Residual Responses, 500 Hz to 1 kHz: ____ -130 dBm

6. Set BANDWIDTH to 30 Hz (8552B) or 50 Hz (8552A), SCAN WIDTH PER DIVISION to 2 kHz and SCAN TIME PER DIVISION to 5 SECONDS. Tune FREQUENCY to 11 kHz. All residual responses should be below -130 dBm:

Residual Responses, 1 kHz to 20 kHz: ____ -130 dBm

7. Set RANGE to 0-300 kHz and tune FREQUENCY to 30 kHz. All residual responses should be below -130 dBm:

Residual Responses, 20 kHz to 40 kHz: ____ -130 dBm

8. Tune FREQUENCY slowly to 300 kHz. All residual responses should be below -130 dBm:

Residual Responses, 40 kHz to 300 kHz: ____ -130 dBm

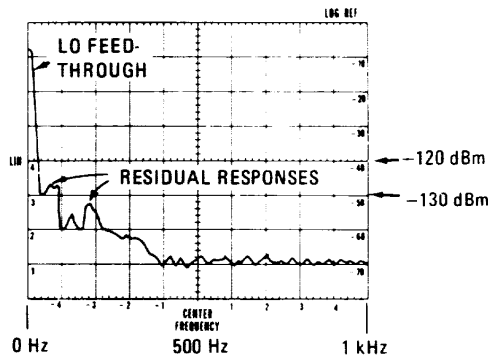

Figure 4-6. Residual Responses Display

PERFORMANCE TESTS

4-21. SPURIOUS RESPONSES

SPECIFICATION: Input signal level < INPUT LEVEL setting: out of band mixing responses, harmonic and intermodulation distortion products are all more than 70 dB below the input signal level 5 kHz to 300 kHz; 60 dB, 20 Hz to 5 kHz. Third order intermodulation products are more than 70 dB below the input signal level, 5 kHz to 300 kHz with signal separation > 300 Hz.

DESCRIPTION: An oscillator, with low harmonic distortion, is connected through a bandpass filter, to the analyzer. Any harmonic distortion due to the analyzer is read on the CRT display. Then intermodulation distortion is checked using a two-tone test.

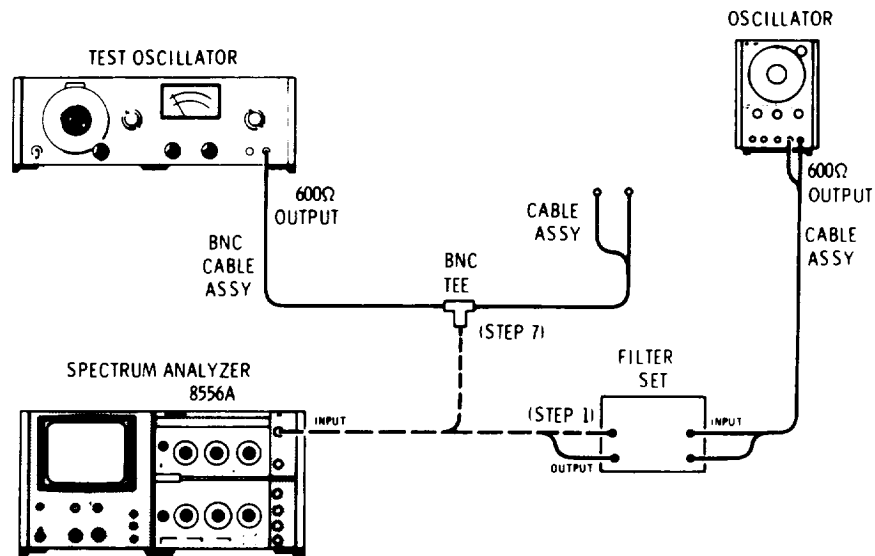

Figure 4-7. Spurious Responses Test Setup

EQUIPMENT:

Test Oscillator	HP 651B
Oscillator	HP 204D
BNC Tee	HP 1250-0781
BNC Cable Assy	HP 10503A
Cable Assy	HP 11000A
Cable Assy	HP 11001A
Filter Set	White Model 2640

PROCEDURE:

1. Connect Oscillator through Filter Set to analyzer INPUT as shown in Figure 4-7.

PERFORMANCE TESTS

4-21. SPURIOUS RESPONSES (cont'd)

2. Set analyzer as follows:

RANGE..... 0-300 kHz
 FREQUENCY 50 kHz
 FINE TUNE Centered
 BANDWIDTH..... 100 Hz
 SCAN WIDTH..... PER DIVISION
 PER DIVISION 500 Hz
 INPUT LEVEL..... -10 dBm/dBV
 dBm/dBV..... dBV
 20 kHz MARKERS Out
 SCAN TIME PER DIVISION 0.5 SECONDS
 LOG/LINEAR..... 10 dB LOG
 LOG REF LEVEL..... -10 dBm/dBV
 Vernier ccw
 BASE LINE CLIPPER..... ccw
 VIDEO FILTER 100 Hz
 SCAN MODE..... INT
 SCAN TRIGGER..... AUTO

3. Switch Filter Set to 50 kHz filter. Set Oscillator for a 50 kHz, CW signal at -10 dBV. Center signal on analyzer CRT display with FREQUENCY and FINE TUNE. Set signal peak to CRT LOG REF graticule with Oscillator AMPLITUDE vernier.

4. Tune FREQUENCY to 100 kHz and 150 kHz; at both frequencies all signals on CRT should be below -70 dB graticule line.

Harmonic Distortion: ___ -70 dB

5. Switch Filter Set to 500 Hz filter. Set SCAN WIDTH to 0-10f, and set Oscillator for a 500 Hz, CW signal at -10 dBV. If necessary, set signal peak to CRT LOG REF graticule with Oscillator AMPLITUDE vernier.

6. Set BANDWIDTH to 30 Hz (with 8552B) or 50 Hz (with 8552A) and set SCAN TIME PER DIVISION to 2 SECONDS. All harmonics of 500 Hz (1 kHz, 1.5 kHz, etc.) should be below -60 dB graticule line:

Harmonic Distortion: ___ -60 dB

7. Disconnect Filter Set from analyzer INPUT. Connect Test Oscillator and Oscillator to BNC Tee; connect BNC Tee directly to INPUT.

8. Set one oscillator for a 70 kHz, CW signal (f_1), and the other oscillator for a 90 kHz, CW signal (f_2). Set both oscillator output attenuators to -40 dBm.

9. Set INPUT LEVEL to -40 dBV, and SCAN WIDTH PER DIVISION to 20 kHz. Set SCAN TIME PER DIVISION to 2 SECONDS and BANDWIDTH to 300 Hz. Set both oscillator AMPLITUDE verniers so that both signal peaks are 3 dB below LOG REF graticule on CRT display.

PERFORMANCE TESTS

4-21. SPURIOUS RESPONSES (cont'd)

10. Refer to Figure 4-8; the signals at 140 kHz ($2f_1$) and 180 kHz ($2f_2$) are oscillator second harmonics. Any second order intermodulation product (due to the analyzer) will occur at 160 kHz ($f_1 + f_2$). Any third order intermodulation products will occur at 50 kHz ($2f_1 - f_2$) and at 110 kHz ($2f_2 - f_1$). The intermodulation products should all be below -70 dB graticule line:

Intermodulation Products Above 5 kHz: ___-70 dB

11. Set one oscillator for a 1.7 kHz, CW signal (f_1), and the other oscillator for a 2 kHz, CW signal (f_2).

12. Set SCAN WIDTH PER DIVISION knob to 500 Hz, and set BANDWIDTH to 30 Hz (with 8552B IF Section) or 50 Hz (with 8552A IF Section). If necessary, tune ZERO ADJ until LO feedthrough is centered at far left graticule line.

13. If necessary, use oscillator AMPLITUDE verniers to set both signal peaks 3 dB below LOG REF graticule on CRT. The signals at 3.4 kHz ($2f_1$) and 4.0 kHz ($2f_2$) are oscillator second harmonics. Any second order intermodulation product will occur at 3.7 kHz ($f_1 + f_2$); this will always be centered between the two second harmonics. Any third order intermodulation product will occur at 1.4 kHz ($2f_1 - f_2$) and at 2.3 kHz ($2f_2 - f_1$). The intermodulation products should all be below -60 dB graticule line:

Intermodulation Products Below 5 kHz: ___-60 dB

NOTE

With the 8552A IF Section, the close-in third order intermodulation products will be hidden in the skirts of the fundamental frequencies.

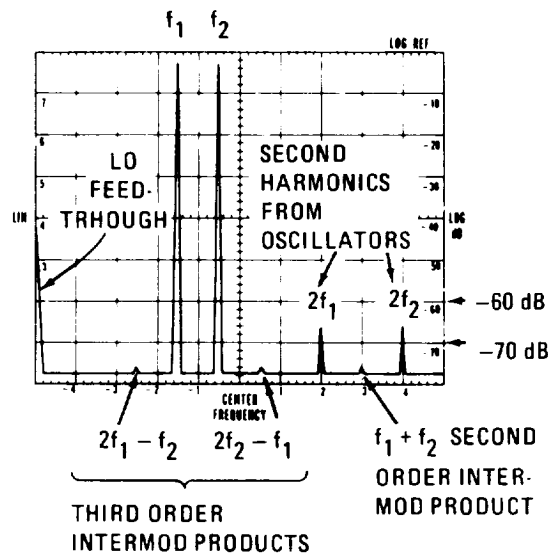

Figure 4-8. Intermodulation Distortion Products Display

PERFORMANCE TESTS

4-22. RESIDUAL FM

SPECIFICATION: With 8552B IF Section: Sidebands >60 dB down 50 Hz or more from CW signal, scan time ≥ 1 sec/div, 10 Hz bandwidth. With 8552A IF Section: Less than 20 Hz peak-to-peak.

DESCRIPTION: The test is written in two parts: the first part is for the 8552B and tests residual FM by checking a stable, CW signal for close-in sidebands. The second part is for the 8552A; the signal is slope detected on the linear portion of the IF filter skirt, then any detected FM is displayed in the time domain.

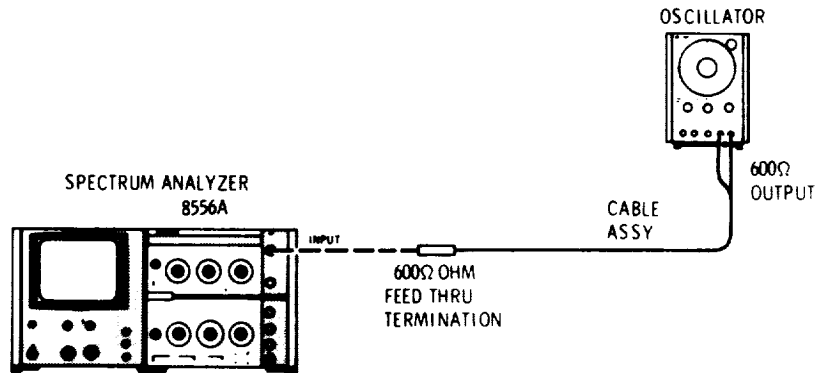

Figure 4-9. Residual FM Test Setup

EQUIPMENT:

Oscillator	HP 204D
Cable Assy.....	HP 11001A
600 Ohm Feed Thru Termination	HP 11095A

PROCEDURE:

1. Connect equipment as shown in Figure 4-9, connecting the oscillator to analyzer INPUT through the 600 Ohm Feed Thru Termination.

2. Set analyzer as follows:

RANGE.....	0-30 kHz
FREQUENCY	2 kHz
FINE TUNE	Centered
BANDWIDTH.....	100 Hz
SCAN WIDTH	PER DIVISION
PER DIVISION	500 Hz
INPUT LEVEL.....	-20 dBm/dBV
20 kHz MARKERSOut
dBm/dBV	600 O dBm
SCAN TIME PER DIVISION	0.1 SECONDS
LOG/LINEAR.....	10 dB LOG
LOG REF LEVEL.....	-20 dBm/dBV
VIDEO FILTER.....	OFF
BASE LINE CLIPPER	ccw
SCAN MODE.....	.INT
SCAN TRIGGER.....	.AUTO

3. Set oscillator for a 2 kHz, CW signal at -20 dBm (read on analyzer CRT). Set NORM/LOW DIST switch on oscillator rear panel to LOW DIST. If using an 8552B IF Section, proceed to step 4. If using an 8552A IF Section, skip to step 6.

PERFORMANCE TESTS

4-22. RESIDUAL FM (cont'd)

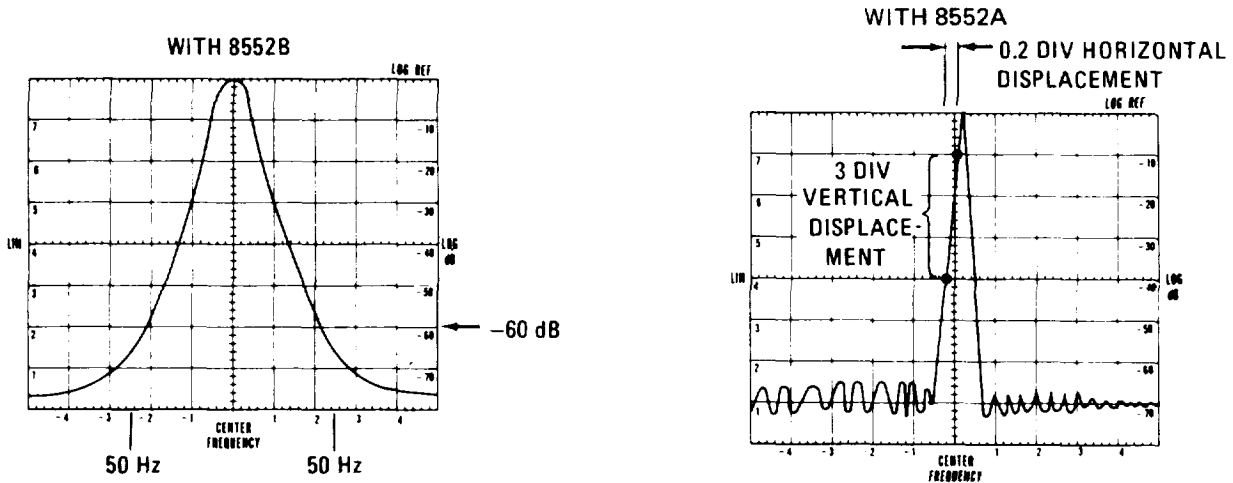

Figure 4-10. Residual FM Display

4. Center signal on CRT display with FREQUENCY and FINE TUNE. Set BANDWIDTH to 10 Hz, SCAN TIME PER DIVISION to 2 SECONDS and SCAN WIDTH to 20 Hz. Re-center signal if necessary and set VIDEO FILTER to 10 Hz.
5. All sidebands 2.5 divisions (50 Hz) from CENTER FREQUENCY graticule should be below -60 dB graticule line (see Figure 4-10):

60 Hz Sidebands (8552B): _____ -60 dB

6. If using an 8552A, set LOG/LINEAR to LINEAR and LINEAR SENSITIVITY to 10 mV/DIV. Center signal on CRT display with FREQUENCY and FINE TUNE; set SCAN WIDTH PER DIVISION to 200 Hz and BANDWIDTH to 100 Hz.
7. Using LINEAR SENSITIVITY vernier, set signal peak to top horizontal graticule line (see Figure 4-10). Then FINE TUNE so that upward slope of signal intersects CENTER FREQUENCY graticule line 1 division from the top. Note where upward slope of signal intersects middle (4) horizontal graticule line.

Horizontal Displacement: _____ divisions

8. Use the horizontal displacement to calculate demodulation sensitivity:
 - a. Convert horizontal displacement into hertz. For example, (200 Hz SCAN WIDTH PER DIVISION) x (0.2 div) = 40 Hz.
 - b. Calculate demodulation sensitivity by dividing the vertical displacement in divisions into horizontal displacement in Hz. For example, $\frac{40 \text{ Hz}}{3 \text{ div}} = \frac{13.1 \text{ Hz}}{\text{div}}$
9. Turn SCAN WIDTH to ZERO. Tune FREQUENCY and FINE TUNE for a response level within the calibrated three division range (from 1 division from the top to the center horizontal graticule line).
10. Measure the peak-to-peak deviation and multiply it by the demodulation sensitivity obtained in step 8b above. For example, $0.5 \text{ div p-p signal deviation} \times 13.3 \frac{\text{Hz}}{\text{div}} = 6.65 \text{ Hz}$.

Residual FM (8552A): __ 20 Hz

PERFORMANCE TESTS

4-23. NOISE SIDEBANDS

SPECIFICATION: More than 90 dB below CW signal, 3 kHz away from signal with a 100 Hz IF bandwidth.

DESCRIPTION: A stable CW signal is applied to the analyzer. The amplitude of the noise sidebands are measured on the CRT display.

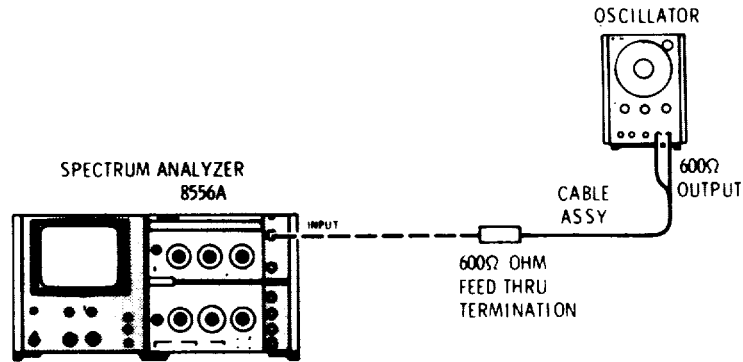

Figure 4-11. Noise Sidebands Test Setup

EQUIPMENT:

Oscillator	HP 204D
Cable Assy.	HP 11001A
600 Ohm Feed Thru Termination	HP 11095A

PROCEDURE:

1. Connect equipment as shown in Figure 4-11, connecting the Oscillator to analyzer INPUT through the 600 Ohm Feed Thru Termination.

2. Set analyzer as follows:

RANGE.....	0-30 kHz
FREQUENCY	15 kHz
FINE TUNE	Centered
BANDWIDTH.....	100 Hz
SCAN WIDTH.....	PER DIVISION
PER DIVISION	2 kHz
INPUT LEVEL.....	-20 dBm/dBV
20 kHz MARKERS	Out
dBm/dBV600 O dBV
SCAN TIME PER DIVISION	0.5 SECONDS
LOG/LINEAR.....	10 dB LOG
LOG REF LEVEL.....	0 dBm/dBV

PERFORMANCE TESTS

4-23. NOISE SIDEBANDS (cont'd)

VIDEO FILTER.....OFF
 BASE LINE CLIPPER......CCW
 SCAN MODE..... INT
 SCAN TRIGGER..... AUTO

3. Set Oscillator for a 15 kHz, CW signal at about 0 dBm. Center the signal on analyzer CRT display with FREQUENCY and FINE TUNE.
4. Set signal peak to LOG REF graticule on CRT with Oscillator AMPLITUDE vernier. Set VIDEO FILTER to 10 Hz (with 8552B IF Section) or 100 Hz (with 8552A IF Section). Set SCAN TIME PER DIVISION to 5 SECONDS.
5. Set LOG REF LEVEL to -20 dBm. Average level of noise sidebands more than 1.5 division (3 kHz) away from signal should be below -70 dB graticule (-90 dBm).

Noise Sidebands, >90 dB down: _____ -90 dBm

NOTE

Average level of noise sidebands is read at the mid-point of the noise on the CRT display (see Figure 4-12).

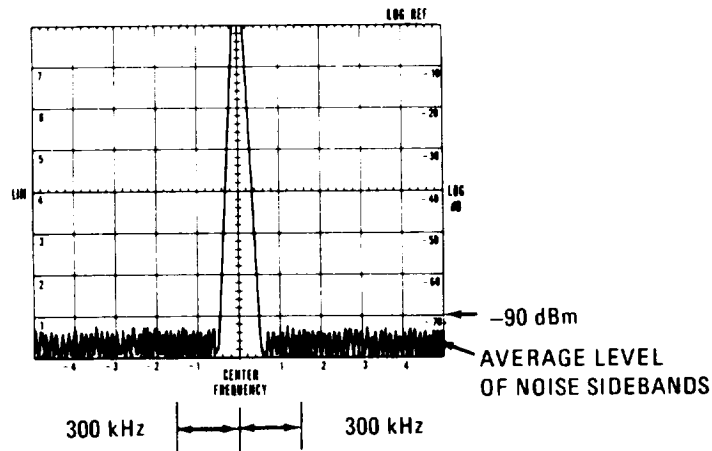

Figure 4-12. Noise Sidebands Display

PERFORMANCE TESTS

4-24. INPUT LEVEL CONTROL AND GAIN COMPRESSION

SPECIFICATIONS:

INPUT LEVEL Control: -10 to -60 dBm/dBV in 10 dB steps.

Accuracy ± 0.2 dB. Marking indicates maximum input levels for 70 dB spurious-free dynamic range. Gain Compression: For input signal level 20 dB above INPUT LEVEL setting, gain compression is less than 1 dB.

DESCRIPTION: A Test Oscillator's calibrated attenuator is used to test the accuracy of the INPUT LEVEL control. Any error is read on a Digital Voltmeter connected to the analyzer's VERTICAL OUTPUT. Next, compression is checked by setting the oscillator 20 dB above the INPUT LEVEL setting.

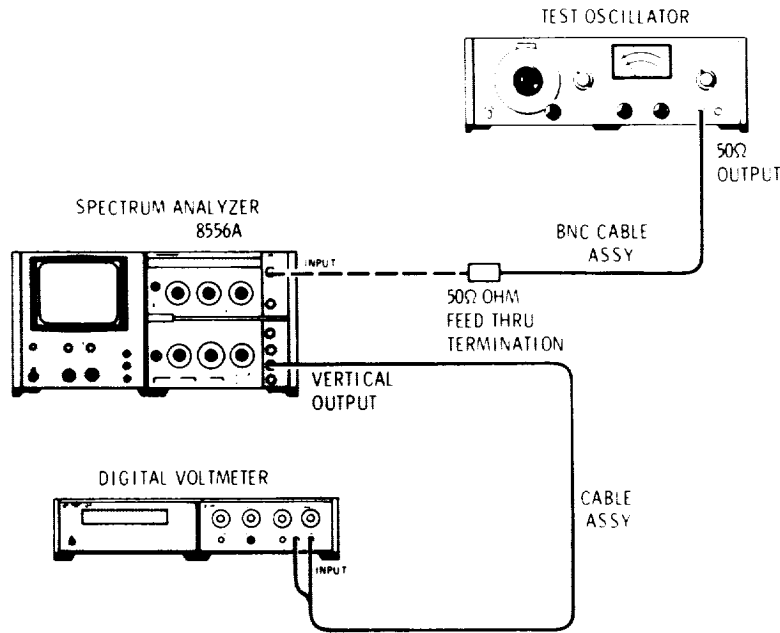

Figure 4-13. Input Level Control and Gain Compression Test Setup

EQUIPMENT:

Test Oscillator	HP 651B
Digital Voltmeter	HP 3480B/3484A, Option 042
BNC Cable Assy.....	HP 10503A
50 Ohm Feed Thru Termination.....	HP 11048B
Cable Assy.....	HP 11001A

PROCEDURE:

1. Connect equipment as shown in Figure 4-13, connecting the Test Oscillator to INPUT through the 50 Ohm Feed Thru Termination and the Digital Voltmeter to VERTICAL OUTPUT.

PERFORMANCE TESTS

4-24. INPUT LEVEL CONTROL AND GAIN COMPRESSION (cont'd)

2. Set analyzer as follows:

RANGE.....0-300 kHz
 FREQUENCY 50 kHz
 FINE TUNE Centered
 BANDWIDTH..... 10 kHz
 SCAN WIDTH..... PER DIVISION
 PER DIVISION..... 1 kHz
 INPUT LEVEL.....-10 dBm/dBV
 20 kHz MARKERS Out
 dBm/dBV..... 50 O dBm
 SCAN TIME PER DIVISION..... 20 MILLISECONDS
 LOG/LINEAR..... 10 dB LOG
 LOG REF LEVEL.....0 dBm/dBV
 Vernier..... ccw
 VIDEO FILTER..... 100 Hz
 BASE LINE CLIPPER.....ccw
 SCAN MODEINT
 SCAN TRIGGER.....AUTO

3. Set Digital Voltmeter on a range that will measure 700.0 mV. Set Test Oscillator OUTPUT ATTENUATOR to -10 dBm; adjust oscillator frequency to 50 kHz and amplitude controls (COARSE and FINE) for zero on dBm meter scale.
4. Adjust analyzer FREQUENCY and FINE TUNE to peak signal at center of CRT display. Set SCAN WIDTH to ZERO. Adjust oscillator amplitude controls until Digital Voltmeter reads -700.0 mV.
5. To test INPUT LEVEL control, set INPUT LEVEL and oscillator OUTPUT ATTENUATOR as shown below. In each case, voltmeter should read -700.0 ±2.0 mV:

INPUT LEVEL/OUTPUT ATTENUATOR Settings	INPUT LEVEL Error Reference
-10 dBm	-698.0 _____ -702.0 mV
-20 dBm	-698.0 _____ -702.0 mV
-30 dBm	-698.0 _____ -702.0 mV
-40 dBm	-698.0 _____ -702.0 mV
-50 dBm	-698.0 _____ -702.0 mV
-60 dBm	-698.0 _____ -702.0 mV

6. To test gain compression, set analyzer INPUT LEVEL and oscillator OUTPUT ATTENUATOR to -10 dBm and adjust oscillator amplitude controls for zero on dBm meter scale.
7. Set LOG/LINEAR to LINEAR and LINEAR SENSITIVITY to 20 mV/DIV; adjust LINEAR SENSITIVITY vernier for -700 mV read on Digital Voltmeter.
8. Set oscillator OUTPUT ATTENUATOR to +10 dBm; set LINEAR SENSITIVITY to 0.2 V/DIV. Digital Voltmeter should read -700 ±84 mV:

-616____-784 mV

PERFORMANCE TESTS

4-25. TRACKING GENERATOR SPECTRAL PURITY

SPECIFICATIONS:

Harmonic Signals: > 40 dB down.
 Spurious Outputs: >50 dB down.

NOTE

Testing the analyzer's residual FM also tests the tracking generator's residual FM.

DESCRIPTION: A separate Spectrum Analyzer is used to measure the harmonic and spurious outputs from the 8556A under test.

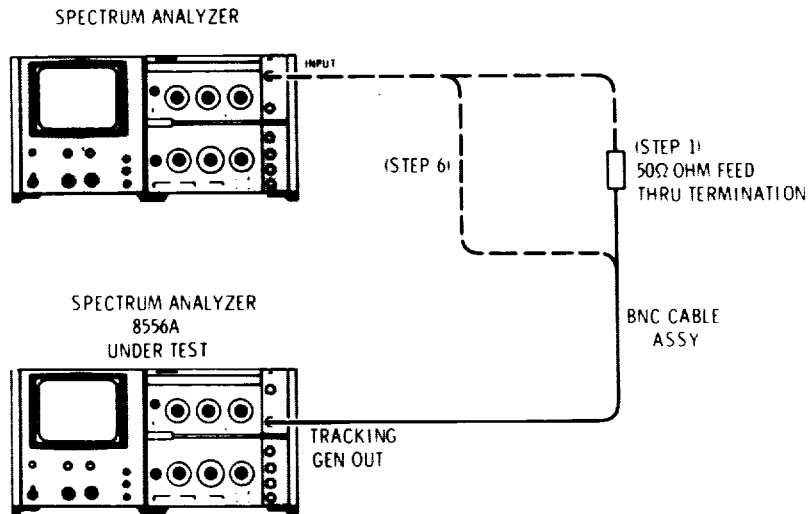

Figure 4-14. Tracking Generator Spectral Purity Test Setup

EQUIPMENT:

Spectrum Analyzer.....	HP 8556A/8552B/141T
50 Ohm Feed Thru Termination.....	HP 11048B
BNC Cable Assy.....	HP 10503A

NOTE

If a second spectrum analyzer is not available, an HP 310A Wave Analyzer can be used to test spectral purity.

PROCEDURE:

1. Connect equipment as shown in Figure 4-14, connecting TRACKING GEN OUT of 8556A under test to INPUT of separate Spectrum Analyzer; connect through 50 Ohm Feed Thru Termination.

PERFORMANCE TESTS

4-25. TRACKING GENERATOR SPECTRAL PURITY (cont'd)

2. Set 8556A under test as follows:

RANGE..... 0-30 kHz
 FREQUENCY 20 kHz
 SCAN WIDTH.....ZERO
 TRACKING GEN LEVEL..... Full cw

3. Set separate Spectrum Analyzer as follows:

RANGE..... 0-300 kHz
 FREQUENCY 200 kHz
 FINE TUNE Centered
 BANDWIDTH..... 300 Hz
 SCAN WIDTH..... 0-10f
 PER DIVISION 20 kHz
 INPUT LEVEL..... -10 dBm/dBV
 20 kHz MARKERS Out
 dBm/dBV..... 50 O dBm
 SCAN TIME PER DIVISION 0.5 SECONDS
 LOG/LINEAR..... 10 dB LOG
 LOG REF LEVEL..... 10 dBm/dBV
 VIDEO FILTER OFF
 SCAN MODE..... INT
 SCAN TRIGGER..... AUTO
 BASE LINE CLIPPER..... .ccw

4. Using separate Spectrum Analyzer LOG REF LEVEL vernier, position peak of 20 kHz signal at LOG REF graticule on CRT. All harmonics of 20 kHz (40 kHz, 60 kHz, 80 kHz, etc.) should be below -40 dB graticule:

Harmonics:____ -40 dB

5. Switch Spectrum Analyzer SCAN WIDTH to PER DIVISION. All harmonics of 20 kHz should be below -40 dB graticule:

Harmonics:____ -40 dB

6. Switch SCAN WIDTH to 0-10f. On 8556A under test, set TRACKING GEN LEVEL to CAL 100 mV. Disconnect 50 Ohm Feed Thru from Spectrum Analyzer INPUT; connect BNC Cable Assembly directly to INPUT.

7. Set Spectrum Analyzer LOG REF LEVEL to 0 dBm and use vernier to reset peak of 20 kHz signal to LOG REF graticule on CRT.

8. All spurious signals on CRT (that is, all signals excepting LO feedthrough, 20 kHz, and 20 kHz harmonics) should be below -50 dB graticule line:

Spurious:_____ -50 dB

9. Switch SCAN WIDTH to PER DIVISION. All spurious signals should be below -50 dB graticule line:

Spurious:_____ -50 dB

Table 4-2. Performance Test Record (1 of 2)

Hewlett-Packard Model 8556A Spectrum Analyzer LF Section		Test Performed by _____			
Serial No. _____		Date _____			
Para. No.	Test Description	Measurement Units	Min.	Actual	Max.
4-14	Tracking Generator Amplitude				
Step: 3.	Amplitude Accuracy	mV	96.5	_____	103.5
5.	Amplitude Range	V	3	_____	
7.	Frequency Response	dB		_____	0.5
4-15	Marker Accuracy				
Step: 7.	Marker Accuracy (300 kHz)	Hz	299,970	_____	300,030
9.	Marker Accuracy (280 kHz)	Hz	279,972	_____	280,028
4-16	Scan Width Accuracy				
Step: 3.	With 8552B (20 kHz/DIV)	Divisions	+3.76	_____	+4.24
	With 8552A (20 kHz/DIV)	Divisions	+3.60	_____	+4.40
5.	With 8552B (5 kHz/DIV)	Divisions	+3.76	_____	+4.24
	With 8552A (5kHz/DIV)	Divisions	+3.60	_____	+4.40
4-17	Center Frequency Accuracy				
Step: 2.	With 8552B (0-300 kHz)	Divisions	-3	_____	+3
	With 8552A (0-300 kHz)	Divisions	-5	_____	+5
3.	With 8552B (0-30 kHz)	Divisions	-1	_____	+1
	With 8552A (0-30 kHz)	Divisions	-2	_____	+2
4-18	Frequency Response				
Step: 7.	1 kHz	mV	683.9	_____	761.1
	3 kHz	mV	683.9	_____	761.1
	5 kHz	mV	683.9	_____	761.1
	10 kHz	mV	683.9	_____	761.1
	20 kHz	mV	683.9	_____	761.1
	30 kHz	mV	683.9	_____	761.1
8.	50 kHz	mV	683.9	_____	761.1
	100 kHz	mV	683.9	_____	761.1
	150 kHz	mV	683.9	_____	761.1
	200 kHz	mV	683.9	_____	761.1
	250 kHz	mV	683.9	_____	761.1
	300 kHz	mV	683.9	_____	761.1
4-19	Average Noise Level				
Step: 2.	Linear (1 kHz)	nV		_____	400
	50 Ω dBm (1 kHz)	dBm		_____	-122
	dBV (1 kHz)	dBV		_____	-132
	600 Ω dBm (1 kHz)	dBm		_____	-130
4.	Linear (10 Hz)	nV		_____	40
	50 Ω dBm (10 Hz)	dBm		_____	-142
	dBV (10 Hz)	dBV		_____	-152
	600 Ω dBm (10 Hz)	dBm		_____	-150
4-20	Residual Responses				
Step: 4.	Line Related	dBm		_____	-120
5.	500 Hz to 1 kHz	dBm		_____	-130
6.	1 kHz to 20 kHz	dBm		_____	-130

Table 4-2. Performance Test Record (cont'd)

Para. No.	Test Description	Measurement Units	Min	Actual	Max
4-20	Residual Responses (cont'd)				
7.	20 kHz to 40 kHz	dBm		_____	-130
8.	40 kHz to 300 kHz	dBm		_____	-130
4-21	Spurious Responses				
Step 4.	Harmonic Distortion (5 kHz to 300 kHz)	dB		_____	-70
6.	Harmonic Distortion (20 Hz to 5 kHz)	dB		_____	-60
10.	Intermod. Products Above 5 kHz	dB		_____	-70
	Intermod. Products Below 5 kHz	dB		_____	-60
4-22	Residual FM				
Step 5.	60 Hz Sidebands (8552B)	dB		_____	-60
7.	Horizontal Displacement	Divisions		_____	
10.	Residual FM (8552A)	Hz		_____	20
4-23	Noise Sidebands				
Step 5.	Noise Sidebands	dBm		_____	-90
4-24	Input Level Control and Gain Compression				
Step 5.	INPUT LEVEL: -10 dBm	mV	-698.0	_____	-702.0
	-20 dBm	mV	-698.0	_____	-702.0
	-30 dBm	mV	-698.0	_____	-702.0
	-40 dBm	mV	-698.0	_____	-702.0
	-50 dBm	mV	-698.0	_____	-702.0
	-60 dBm	mV	-698.0	_____	-702.0
8.	Gain Compression	mV	-616	_____	-784
4-25	Tracking Generator Spectral Purity				
Step 4.	Harmonics	dB		_____	-40
5.	Harmonics	dB		_____	-40
8.	Spurious	dB		_____	-50
	Spurious	dB		_____	-50

SECTION V ADJUSTMENTS

5-1. INTRODUCTION

5-2. This section describes adjustments required to return the analyzer LF Section to peak operating condition when repairs are required. Included in this section are test setups, and check and adjustment procedures. A test card for recording data is included at the back of this section. Adjustment location photographs are contained in foldouts in Section VIII.

5-3. Record data, taken during adjustments, in the spaces provided or in the data test card at the end of this section. Comparison of initial data with data taken during periodic adjustments assists in preventive maintenance and troubleshooting.

5-4. TEST EQUIPMENT REQUIRED

5-5. Tables 1-4 and 1-5 contain a tabular list of test equipment and test accessories required in the adjustment procedures. In addition, the tables contain the required minimum specifications and a suggested manufacturers model number.

5-6. In addition to the test equipment and test accessories in Tables 1-4 and 1-5, a Display Section and an IF Section are required. Perform the Display Section and IF Section adjustments prior to performing the LF Section adjustments.

5-7. Posidriv Screwdrivers

5-8. Many screws in the instrument appear to be Phillips, but are not. Table 1-5 gives the name and number of the Posidriv screwdrivers designed to fit these screws. To avoid damage to the screw slots, Posidriv screwdrivers should be used.

5-9. Blade Tuning Tools

5-10. For adjustments requiring a non-metallic metal-blade tuning tool, use the J.F.D. Model No. 5284 (HP 8710-1010). In situations not requiring non-metallic tuning tools, an ordinary small screwdriver or other suitable tool is sufficient. No matter what tool is used, never try to force any adjustment control in the analyzer. This is especially critical when tuning variable slug-tuned inductors, and variable capacitors.

5-11. HP 11592A Service Kit

5-12. The HP 11592A Service Kit is an accessory item available from Hewlett-Packard for use in maintaining

both the LF and IF Sections of the spectrum analyzer. Some adjustments can be made without this kit by removing the top cover from both the LF Section and the Display Section. However, this procedure exposes dangerous potentials in the Display Section chassis and should not be used unless absolutely necessary. All adjustments can and should be performed with the analyzer plug-ins installed on the extender cables provided in the service kit.

5-13. Table 1-5, Test Equipment Accessories, contains a detailed description of the contents of the service kit, and any item in the kit may be ordered separately. In the case of the 11592-60015 Extender Cable Assembly, the wiring is especially critical and fabrication should not be attempted. However, other items in the kit may be built if desired.

5-14. Extender Cable Installation

5-15. Push the front panel latch in the direction indicated by the arrow until the latch disengages and pops out from the panel. Pull the plug-ins out of the instrument. Remove the top cover of the LF Section.

5-16. Place the plate end of the HP 11592-60015 Extender Cable Assembly in the Display Section and press firmly into place so that the plugs make contact. The plate and plugs cannot be installed upside down as the plate has two holes corresponding to the two guide rods in the mainframe.

5-17. Connect the upper cable plug to the LF Section and the lower cable plug to the IF Section. The plugs are keyed so that they will go on correctly and will not make contact upside down.

5-18. FACTORY SELECTED COMPONENTS

5-19. Table 8-1 contains a list of factory selected components by reference designation, basis of selection, and schematic diagram location. Factory selected components are designated by an asterisk (*) on the schematic diagrams in Section VIII.

5-20. RELATED ADJUSTMENTS

5-21. These adjustments should be performed when the troubleshooting information in Section VIII indicates that an adjustable circuit is not

operating correctly. Perform the adjustments after repairing, or replacing, the circuit. The troubleshooting procedures specify the required adjustments.

5-22. Perform any required Display Section and IF Section adjustments before performing the LF Section adjustments. Also, perform the voltage checks in paragraph 5-23 before performing any of the following adjustments.

ADJUSTMENTS

5-23. VOLTAGE CHECKS

REFERENCE: Service Sheet 12 and IF Section and Display Section Operating and Service Manuals.

DESCRIPTION: Dc operating voltages for the LF Section are obtained from the Display Section, the IF Section, and an isolated power supply in the LF Section. If any of the operating voltages are out of limits, they should be corrected before performing any of the LF Section adjustments.

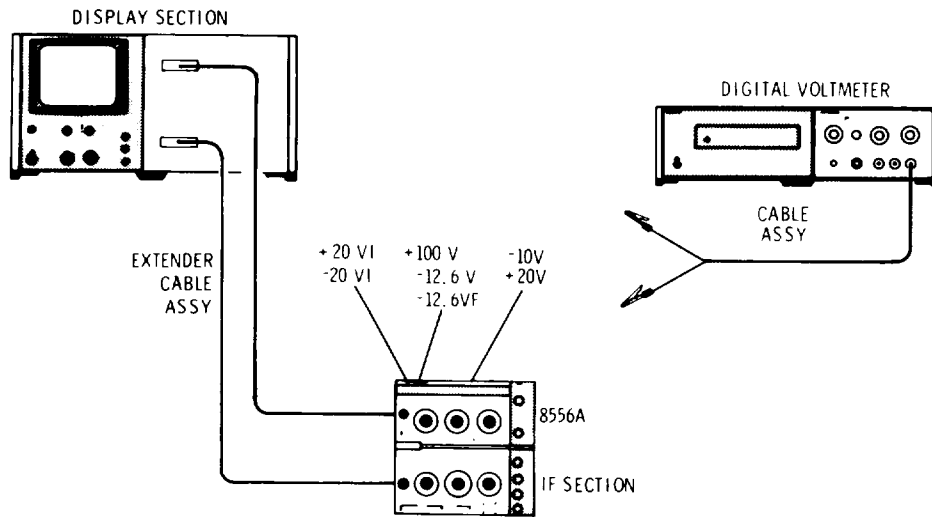

Figure 5-1. Voltage Checks Test Setup

EQUIPMENT:

Digital Voltmeter	HP 3480B/3484A Option 042
Cable Assy	HP 11002A
Extender Cable Assy	HP 11592-60015

ADJUSTMENTS

5-23. VOLTAGE CHECKS (cont'd)

PROCEDURE:

1. Extend LF and IF Sections on Extender Cable Assembly as shown in Figure 5-1.
2. Connect Digital Voltmeter from -10V test point and +20V test point (located on A7 assembly cover) to chassis ground. The voltages should be $-10 \pm 0.02V$ and $+20 \pm 0.10V$:

-9.98___-10.02V
+19.90___+20.10V
3. If either voltage is out of limits, see IF Section Operating and Service Manual.
4. Connect voltmeter from -12.6V test point and +100V test point (located at left, rear of Master Board Assembly All) to chassis ground. The voltages should be $-12.6 \pm 0.2V$ and $+100 \pm 1.0V$:

-12.4___-12.8V
+99.0___+101.0V
5. If either voltage is out of limits, see Display Section Operating and Service Manual.
6. Connect voltmeter from -12.6VF test point (located at left, rear of master board) to chassis ground. (20 kHz MARKERS button on analyzer front panel should be out.) The voltage should be $-11.5 \pm 0.5V$:

-11.0___-12.0V
7. Connect voltmeter from 20 VI test point and -20 VI test point (located on A5 assembly cover) to A5 assembly cover ground (not chassis ground). The voltages should be $+20 \pm 2V$ and $-20 \pm 2V$:

+18___+22V
-18___-22V
8. If any of the voltages checked in steps 6 and 7 are out of limits, see Service Sheet 12 in this manual.

ADJUSTMENTS

5-24. PRE-ATTENUATOR ADJUSTMENTS: COMP AND C IN

REFERENCE: Service Sheet 4.

DESCRIPTION: Pre-attenuator attenuation is checked. Then its flatness is set, adjusting COMP capacitor A5C7, so that attenuation at 300 kHz equals attenuation at 3 kHz. C IN capacitor A5C6 is adjusted so that INPUT capacitance does not change when the attenuator is used.

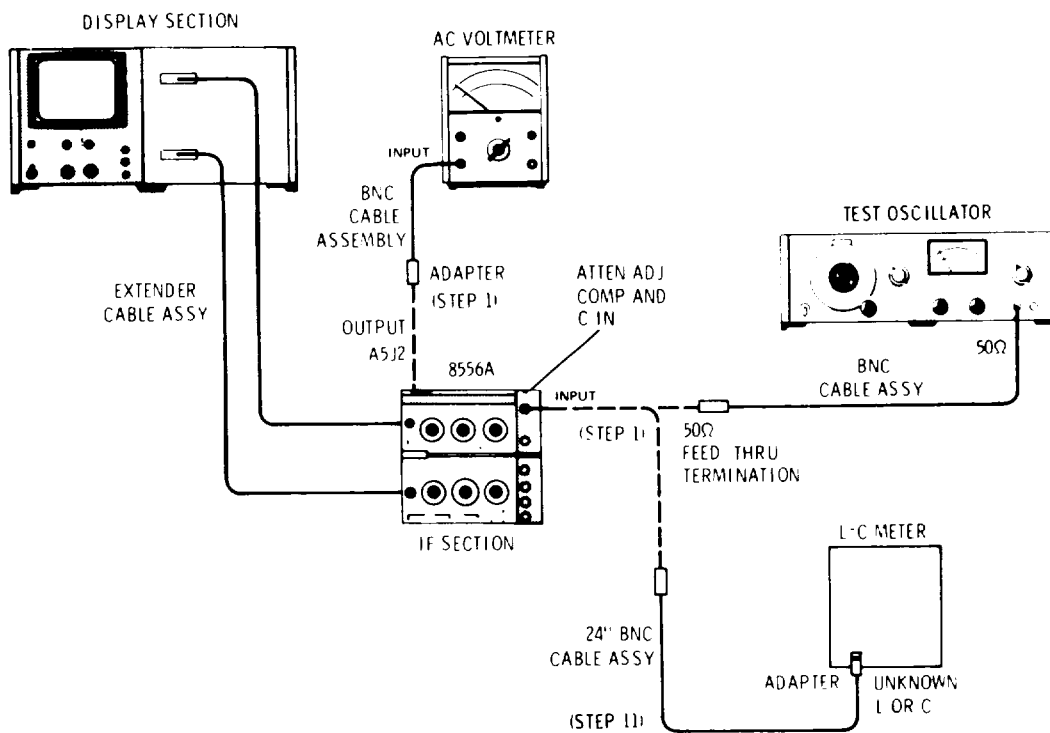

Figure 5-2. Pre-Attenuator Adjustment Test Setup

EQUIPMENT:

L-C Meter	Tektronix Type 130
Test Oscillator	HP 651B
AC Voltmeter	HP 400EL
50 Ohm Feed Thru Termination.....	HP 11048B
BNC Cable Assy.....	HP 10503A
24" BNC Cable Assy.....	HP 11086A
Adapter.....	HP 1250-1236
Adapter.....	HP 1250-0071
Extender Cable Assy	HP 11592-60015
Tuning Tool	HP 8710-1010

PROCEDURE:

1. Connect equipment as shown in Figure 5-2, disconnecting green cable (A3W1) so that AC Voltmeter can be connected to A5J2 (OUTPUT). Connect Test Oscillator to analyzer INPUT through 50 Ohm Feed Thru Termination.

ADJUSTMENTS

5-24. PRE-ATTENUATOR ADJUSTMENTS: COMP AND C IN (cont'd)

2. Set analyzer as follows (controls not specified do not apply):

dBm/dBV..... 50 Ω dBm
 INPUT LEVEL..... -40 dBm/dBV

3. Set Test Oscillator for a 3 kHz -27 dBm signal as follows:

FREQUENCY3.0
 RANGE.....X 1K
 OUTPUT ATTENUATOR -20 dBm
 AMPLITUDE -7 dBm

4. Set AC Voltmeter to measure -10 dB.

5. Adjust Test Oscillator AMPLITUDE (COARSE and FINE) so that AC Voltmeter reads -10.00 dB.

6. Set analyzer INPUT LEVEL to -30 dBm/dBV. Increase 3 kHz signal from Test Oscillator exactly 30 dB by setting OUTPUT ATTENUATOR to +10 dBm.

7. The AC Voltmeter should read -10 dB ±0.20 dB:

-9.8___-10.2 dB

8. Set Test Oscillator to 300 kHz by setting RANGE to X100K (don't change oscillator signal amplitude).

9. Adjust COMP capacitor A5C7 until AC Voltmeter reads within ±0.10 dB of reading in step 7 (taken at 3 kHz):

(step 7) ±0.10 dB, 0.10_____0.10 dB

10. Disconnect AC Voltmeter, Test Oscillator, and 50 Ohm Feed Thru Termination from analyzer. Don't re-connect green cable (A3W1) to A5J2 (OUTPUT). Set analyzer dBm/dBV switch to dBV and input level to -40 dBm/dBV.

11. Connect the 24 inch BNC cable assembly to L-C Meter UNKNOWN L or C input, and set meter to measure 32 pF. Null cable capacitance by zeroing the meter, then connect cable to analyzer INPUT.

12. The L-C Meter should read approximately 32 pF (μμ F):

≈32 pF_____

13. Set analyzer INPUT LEVEL to -30 dBm/dBV. Adjust C IN capacitor A5C6 until L-C Meter reads within ±0.5 pF of reading in step 12:

(step 12) ±0.5 pF, 0.5__0.5 pF

14. Disconnect L-C Meter from analyzer INPUT. Re-connect green cable (A3W1) to A5J2 (OUTPUT). Perform mixer balance adjustments specified in paragraph 5-26.

ADJUSTMENTS

5-25. 50.150 MHz LOCAL OSCILLATOR ADJUSTMENT: A6T1

REFERENCE: Service Sheet 5.

DESCRIPTION: Transformer A6T1 is tuned to peak the signal from the 50.150 MHz local oscillator. Then the signal's frequency and amplitude are checked.

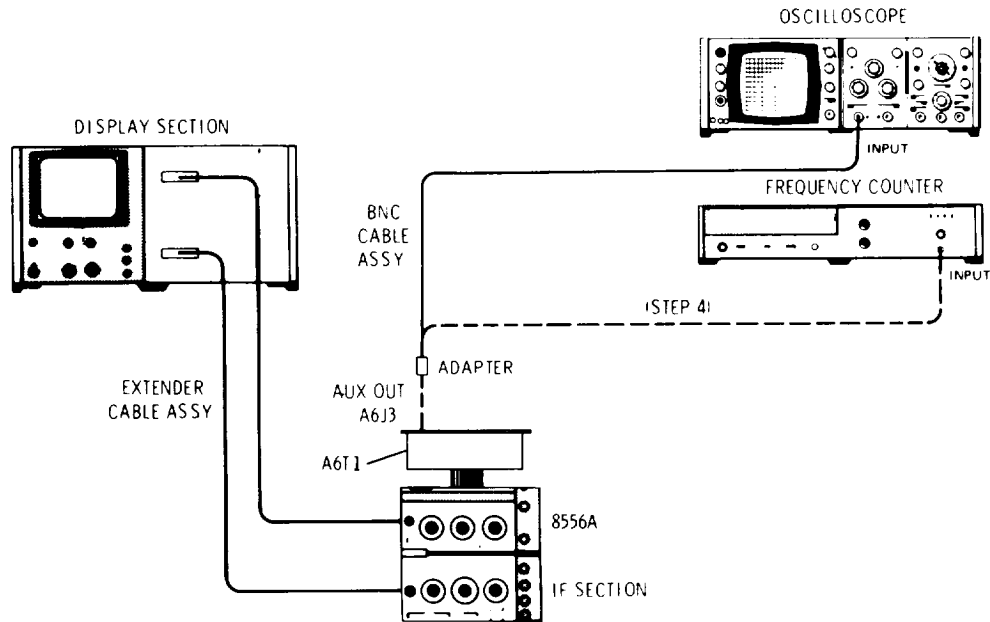

Figure 5-3. 50.150 MHz Local Oscillator Adjustment Test Setup

EQUIPMENT:

Oscilloscope	HP 180A/1801A/1820B
Frequency Counter	HP 5327C
BNC Cable Assy	HP 10503A
Adapter.	HP 1250-1236
Extender Cable Assy	HP 11592-60015
Extender Board.....	HP 5060-0256
Tuning Tool	HP 8710-1010

PROCEDURE:

1. Connect equipment as shown in Figure 5-3. Remove Frequency Converter Assembly A6 from chassis and re-install on extender board. Connect Oscilloscope to A6J3 using BNC cable and adapter.
2. Set Oscilloscope to measure 50.150 MHz at about 1V peak-to-peak by setting TIME/DIV to 0.1 μ sec and VOLTS/DIV to 0.2V.
3. Using non-metallic tuning tool, tune transformer A6T1 for maximum signal on Oscilloscope. Signal level should be 0.9V to 1.6V peak-to-peak.

0.9___1.6V P-P

ADJUSTMENTS

5-25. 50.150 MHz LOCAL OSCILLATOR ADJUSTMENT: A6T1 (cont'd)

4. Disconnect BNC cable from Oscilloscope and connect it to Frequency Counter. Set counter to measure 50.150 MHz.
5. Oscillator frequency should be 50.150 MHz \pm 3.0 kHz:

50.147 _____ 50.153 MHz

6. Disconnect BNC cable from A6 assembly; remove extender board and install assembly into chassis. Re-connect cables to A6J1, J2 and J3. Perform mixer balance adjustments as specified in paragraph 5-26.

5-26. MIXER BALANCE ADJUSTMENTS: C; R and Z

REFERENCE: Service Sheet 5

DESCRIPTION: C, R and Z MIXER BALANCE are adjusted until LO feedthrough measures less than -80 dBm.

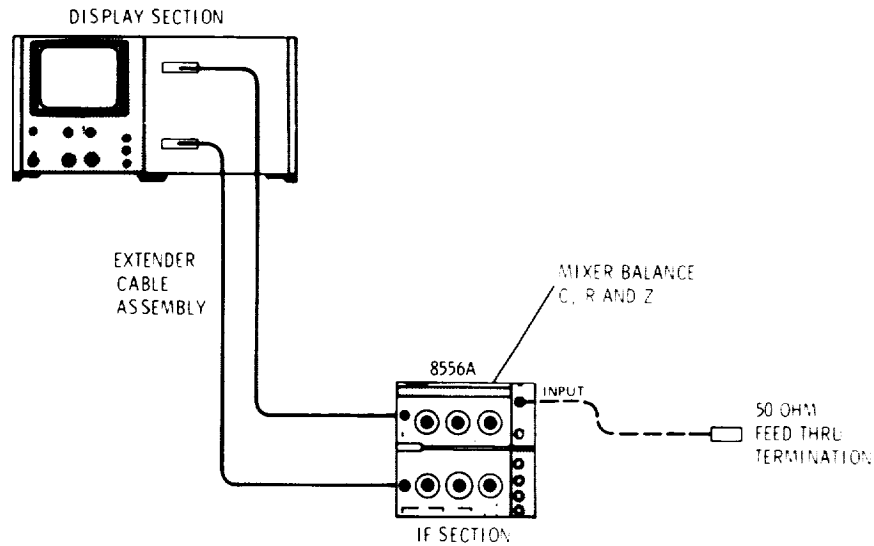

Figure 5-4. Mixer Balance Adjustments Test Setup

EQUIPMENT:

Extender Cable Assy	HP 11592-60015
Tuning Tool	HP 8710-1010
50 Ohm Feed Thru Termination.....	HP 11048B

PROCEDURE:

1. Extend LF and IF Sections on Extender Cable Assembly as shown in Figure 5-4. The A6 assembly should be mounted in chassis with all screws in place. Connect 50 Ohm Feed Thru Termination to analyzer INPUT.

ADJUSTMENTS

5-26. MIXER BALANCE ADJUSTMENTS: C, R and Z (cont'd)

2. Set analyzer controls as follows:

FREQUENCY	0 kHz
BANDWIDTH	3 kHz
SCANWIDTH.....	PER DIVISION
PER DIVISION	10 kHz
INPUT LEVEL	-60 dBm/dBV
dBm/dBV.....	50 O dBm
BASE LINE CLIPPER	ccw
VIDEO FILTER	10 kHz
SCAN TIME PER DIVISION.....	5 MILLISECONDS
LOG/LINEAR	10 dB LOG
LOG REF LEVEL	-40 dBm
SCAN MODE.....	INT
SCAN TRIGGER.....	AUTO

NOTE

This procedure assumes that analyzer has been allowed to warm up at least one-half hour and that it is calibrated as specified in Section III, Figure 3-2.

3. Center LO feedthrough signal on display with FREQUENCY control.
4. Using non-metallic adjustment tool, adjust C and R MIXER BALANCE (A6R5 and C12) for best null of LO feedthrough.
5. Adjust Z MIXER BALANCE (A6C22) for LO feedthrough null, then repeat steps 4 and 5 until LO feedthrough is below -40 dB graticule on display (<-80 dBm):
- _____ -80 dBm
6. Secure top cover on 8556A. Repeat step 4 until LO feedthrough is below -40 dB graticule line.
- _____ -80 dBm
-

5-27. TRACKING GENERATOR ADJUSTMENTS: AMPL ADJ and FLATNESS ADJ

REFERENCE: Service Sheet 7

DESCRIPTION: Tracking generator level is adjusted at 100 kHz, flatness is adjusted at 300 kHz, and flatness is checked across the band from 20 kHz to 300 kHz. Then the generator's ability to deliver power into a load is checked.

NOTE

The following adjustments assume that the analyzer meets its frequency specifications.

ADJUSTMENTS

5-27. TRACKING GENERATOR ADJUSTMENTS: AMPL ADJ and FLATNESS ADJ (cont'd)

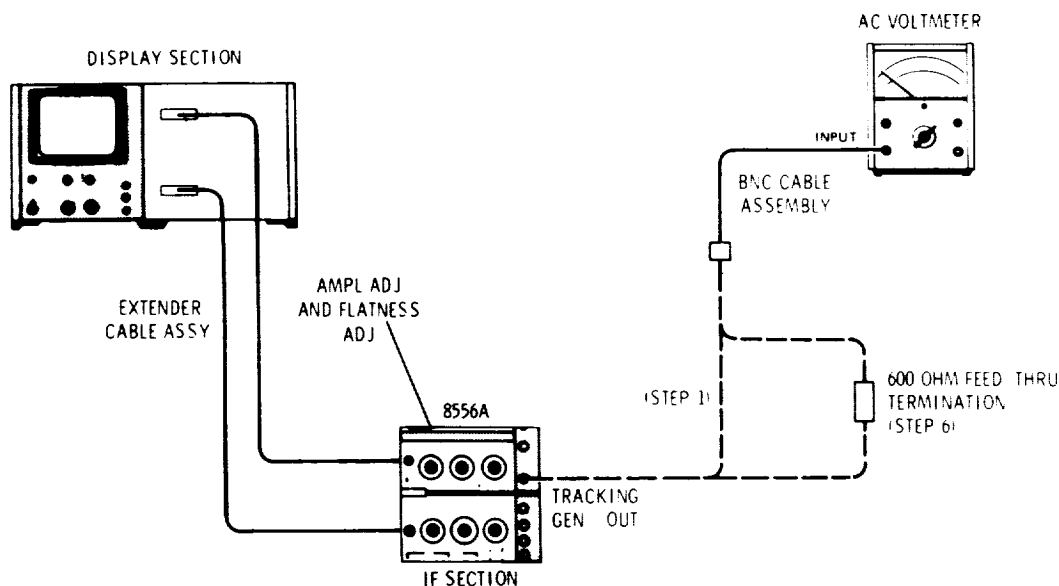

Figure 5-5. Tracking Generator Adjustment Test Setup

EQUIPMENT:

AC Voltmeter	HP400EL
600 Ohm Feed Thru Termination	HP 11095A
24" BNC Cable Assy.....	HP 11086A
Tuning Tool	HP 8710-1010
Extender Cable Assy	HP 11592-60015

PROCEDURE:

1. Connect equipment as shown in Figure 5-5, connecting AC Voltmeter directly to TRACKING GEN OUT with 24" BNC cable.
2. Set analyzer as follows (controls not specified do not apply):

FREQUENCY	100 kHz
SCAN WIDTH	ZERO
RANGE	0-300 kHz
TRACKING GEN LEVEL	CAL 100 mV
20 kHz MARKERS	Out
3. Set AC Voltmeter to read 100 mV full scale and adjust AMPL ADJ (A8A1R1) so that voltmeter reads exactly 100 mV (use non-metallic tuning tool).
4. Set FREQUENCY to 300 kHz and adjust FLATNESS ADJ (A8R9) so that voltmeter reads exactly 100 mV.

ADJUSTMENTS

5-27. TRACKING GENERATOR ADJUSTMENTS: AMPL ADJ and FLATNESS ADJ (cont'd)

5. Slowly tune FREQUENCY from 300 kHz to 20 kHz. The voltmeter should indicate a maximum variation of 5 mV through entire range:

___ 5 mV

6. Connect 600 Ohm Feed Thru Termination between TRACKING GEN OUT and AC Voltmeter. Set TRACKING GEN LEVEL full clockwise. Voltmeter should read ≥ 1.5 V:

1.5 V__

7. Slowly tune FREQUENCY from 20 kHz to 300 kHz. The voltmeter should indicate a maximum variation of 80 mV through entire range:

___ 80 mV

5-28. FREQUENCY CALIBRATION ADJUSTMENT: OFFSET ADJ, 300 kHz ADJ, and ZERO ADJ

REFERENCE: Service Sheet 9

DESCRIPTION: OFFSET ADJ is adjusted, and the dial is calibrated with the ZERO ADJ and 300 kHz ADJ controls.

NOTE

This procedure assumes that analyzer horizontal display calibration has been performed (see Figure 3-2 in Section III).

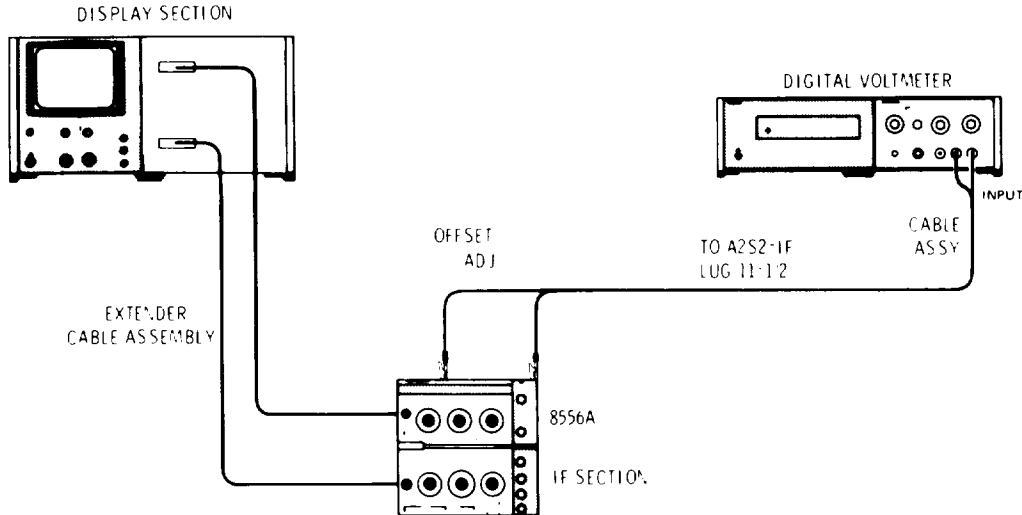

Figure 5-6. Frequency Calibration Adjustment Test Setup

EQUIPMENT

Digital Voltmeter	HP 3480B/3484A Option 042
Cable Assy	HP 11002A
Extender Cable Assy	HP 11592-60015

ADJUSTMENTS

5-28. FREQUENCY CALIBRATION ADJUSTMENT: OFFSET ADJ, 300 kHz ADJ and ZERO ADJ (cont)

PROCEDURE:

1. Connect equipment as shown in Figure 5-6, connecting Digital Voltmeter between Scan Width Switch Assembly A2, wafer S2-1R lug 11½ (where white-red-gray. 928, wire is connected) and chassis ground.
2. Set analyzer controls as follows:

FREQUENCY	0 kHz
FINE TUNE	Centered
RANGE	0-300 kHz
BANDWIDTH.....	10 kHz
SCAN WIDTH.....	PER DIVISION
PER DIVISION	1 kHz
INPUT LEVEL.....	-10 dBm/dBV
BASE LINE CLIPPER.....	ccw
VIDEO FILTER.....	OFF
SCAN TIME PER DIVISION	50 MILLISECONDS
LOG/LINEAR.....	10 dB LOG
SCAN MODE.....	INT
SCAN TRIGGER.....	AUTO

3. Center 300 kHz ADJ, and center OFFSET ADJ (A7R13). Center LO feedthrough signal at CENTER FREQUENCY graticule with ZERO ADJ. Dial should be accurately set to 0 kHz.
4. Adjust OFFSET ADJ for 0.0 ± 5.0 mV read on voltmeter.
5. Set BANDWIDTH to 100 Hz and PER DIVISION to 100 Hz; center signal on display with ZERO ADJ Switch RANGE to 0-30 kHz; signal shift should be less than 150 Hz:

_____ 150 Hz
6. Set BANDWIDTH to 1 kHz, PER DIVISION to 20 kHz and RANGE to 0-300 kHz; push 20 kHz MARKERS switch.
7. Slowly tune FREQUENCY to 300 kHz counting 20 kHz markers as they pass CENTER FREQUENCY graticule on display. Center fifteenth marker (300 kHz) on CENTER FREQUENCY graticule: adjust 300 kHz ADJ so that dial reads 300 kHz when fifteenth marker (300 kHz) is centered.
8. Tune FREQUENCY to 0 kHz. Adjust ZERO ADJ to center LO feedthrough (0 Hz) on display.
9. Repeat steps 7 and 8 until no further adjustment is necessary.

5-29. ANALOGIC CHECKS

REFERENCE: Service Sheet 10 and IF Section Operating and Service Manual.

DESCRIPTION: Perform the display calibration check tabulated below. If an adjustment is required, refer to the analogic adjustment procedure in the IF Section manual.

If the table indicates that the DISPLAY UNCAL light should be off, it is acceptable for the light to be on if the light subsequently goes off when either SCAN TIME PER DIVISION or SCAN WIDTH PER DIVISION is switched one position counter-clockwise.

ADJUSTMENTS

5-29. ANALOGIC CHECKS (cont'd)

Table 5-1. Analogic Display Calibration Check

VIDEO FILTER	SCAN TIME PER DIVISION	BAND-WIDTH	SCAN WIDTH PER DIVISION	SCAN WIDTH	DISPLAY UNCAL LIGHT
10 Hz	2 SECONDS	100 Hz	1 kHz	PER DIVISION	OFF
10 Hz	1 SECOND	100 Hz	1 kHz	PER DIVISION	ON
100 Hz	0.2 SECONDS	1 kHz	10 kHz	PER DIVISION	OFF
100 Hz	0.1 SECONDS	1 kHz	10 kHz	PER DIVISION	ON
10 kHz	10 MILLISECONDS	3 kHz	20 kHz	PER DIVISION	OFF
10 kHz	5 MILLISECONDS	3 kHz	20 kHz	PER DIVISION	ON
OFF	5 MILLISECONDS	3 kHz	20 kHz	ZERO	OFF*
OFF	2 MILLISECONDS	10 kHz	20 kHz	PER DIVISION	OFF
OFF	5 MILLISECONDS	3 kHz	20 kHz	PER DIVISION	OFF
OFF	5 MILLISECONDS	1 kHz	20 kHz	PER DIVISION	ON
OFF	20 MILLISECONDS	1 kHz	10 kHz	PER DIVISION	OFF
OFF	20 MILLISECONDS	300 Hz	10 kHz	PER DIVISION	ON
OFF	50 MILLISECONDS	300 Hz	2 kHz	PER DIVISION	OFF
OFF	50 MILLISECONDS	100 Hz	2 kHz	PER DIVISION	ON
OFF	0.1 SECONDS	100 Hz	500 Hz	PER DIVISION	OFF
OFF	0.1 SECONDS	30 Hz	500 Hz	PER DIVISION	ON
OFF	0.2 SECONDS	30 Hz	100 Hz	PER DIVISION	OFF
OFF	0.2 SECONDS	10 Hz	100 Hz	PER DIVISION	ON
OFF	0.5 SECONDS	10 Hz	20 Hz	PER DIVISION	OFF
OFF	0.5 SECONDS	300 Hz	20 Hz	PER DIVISION	OFF
OFF	0.2 SECONDS	300 Hz	20 kHz	PER DIVISION	ON
OFF	0.2 SECONDS	300 Hz	10 kHz	PER DIVISION	OFF
OFF	0.1 SECONDS	300 Hz	10 kHz	PER DIVISION	ON
OFF	0.1 SECONDS	300 Hz	5 kHz	PER DIVISION	OFF
OFF	50 MILLISECONDS	300 Hz	5 kHz	PER DIVISION	ON
OFF	50 MILLISECONDS	300 Hz	2 kHz	PER DIVISION	OFF
OFF	20 MILLISECONDS	300 Hz	2 kHz	PER DIVISION	ON
OFF	20 MILLISECONDS	300 Hz	1 kHz	PER DIVISION	OFF
OFF	10 MILLISECONDS	300 Hz	1 kHz	PER DIVISION	ON
OFF	10 MILLISECONDS	300 Hz	500 Hz	PER DIVISION	OFF
OFF	5 MILLISECONDS	300 Hz	500 Hz	PER DIVISION	ON
OFF	5 MILLISECONDS	300 Hz	200 Hz	PER DIVISION	OFF
OFF	2 MILLISECONDS	300 Hz	200 Hz	PER DIVISION	ON
OFF	2 MILLISECONDS	300 Hz	100 Hz	PER DIVISION	OFF
OFF	1 MILLISECOND	300 Hz	100 Hz	PER DIVISION	ON
OFF	1 MILLISECOND	300 Hz	50 Hz	PER DIVISION	OFF

* No exception allowed

ADJUSTMENTS

5-30. 8552A 47 MHz LO ADJUSTMENT

REFERENCE: Service Sheet 9 and 8552A IF Section Operating and Service Manual.

DESCRIPTION: On some HP Model 8552A Spectrum Analyzer IF Sections, long term aging may have caused the center frequency of the 47 MHz LO to drift beyond the zero adjustment range of the 8556A. If this is the case, the following simplified 47 MHz LO adjustment procedure can be used to readjust center frequency and tuning accuracy.

EQUIPMENT:

Extender Cable Assy (if not available, see step 1)HP 11592-60015
 Tuning Tool8710-1010

PROCEDURE:

1. Extend LF and IF Sections on Extender Cable Assembly (see paragraph 5-15 for step-by-step procedure). If the Extender Cable Assembly is not available, the adjustment can be made with the LF and IF Sections installed in the Display Section:
 - a. Remove 8552A and 8556A from Display Section.
 - b. Remove bottom covers from Display Section and 8552A.
 - c. Place Display Section on left side and plug 8552A and 8556A into Display Section. Be careful that 8552A does not hang up on Display Section guide rails.

CAUTION

Removing the Display Section bottom cover exposes dangerous potentials (up to 7000 volts).

2. Turn analyzer on and allow to warm up at least one hour.
3. Set analyzer as follows:

RANGE	0-300 kHz
FREQUENCY	100 kHz
FINE TUNE	Centered
BANDWIDTH.....	3 kHz
SCAN WIDTH	PER DIVISION
PER DIVISION	20 kHz
INPUT LEVEL.....	-20 dBm/dBV
ZERO ADJ	Centered (5 turns from stop)
300 kHz ADJ	Centered
20 kHz MARKERSOut
SCAN TIME PER DIVISION	50 MILLISECONDS
LOG/LINEARLOG
LOG REF LEVEL	-10 dBm/dBV
BASE LINE CLIPPERccw
SCAN MODE.....	.INT
SCAN TRIGGER.....	.AUTO
4. If necessary, adjust HORIZONTAL POSITION and GAIN on 8552A for a 10 division horizontal trace.
5. Depress 20 kHz MARKERS switch. Markers should appear at approximately every major vertical graticule line on CRT. Switch 20 kHz MARKERS switch out.

ADJUSTMENTS

5-30. 8552A 47 MHz LO ADJUSTMENT (cont'd)

6. Using non-metallic tuning tool, slowly adjust 8552A A3A2C4 (see Assembly and Adjustment Locations photo in 8552A manual) until the LO feedthrough appears on the CRT (about ± 1 .turn); then adjust 8552A A3A2C4 until LO feedthrough is centered on far left graticule line (see Figure 5-7).
7. Depress 20 kHz MARKERS switch. With LO feedthrough centered on far left graticule line, markers should be evenly spaced with ninth marker (180 kHz) within ± 0.2 division (4 kHz) of the +4 graticule line. If not, adjust 8552A A5R42 TUNING RANGE and A3A2C4 until the 20 kHz markers are aligned on the graticule lines and the LO feedthrough is centered on the far left graticule line. (A5R42 varies marker spacing and A3A2C4 varies location of markers.)
8. Tune FREQUENCY to 0 kHz (FINE TUNE centered), and set SCAN WIDTH PER DIVISION to 1 kHz and SCAN TIME PER DIVISION to 5 MILLISECONDS.
9. Adjust 8552A A2A3C4 until LO feedthrough is centered within ± 2 divisions of center graticule line. Center LO feedthrough exactly on center graticule line with 8556A ZERO ADJ.
10. Tune FREQUENCY to 300 kHz. Adjust 8556A 300 kHz ADJ to center 300 kHz marker on center graticule line.
11. Turn analyzer off, remove 8552A and 8556A from Display Section, replace bottom covers, and reinstall 8556A and 8552A.

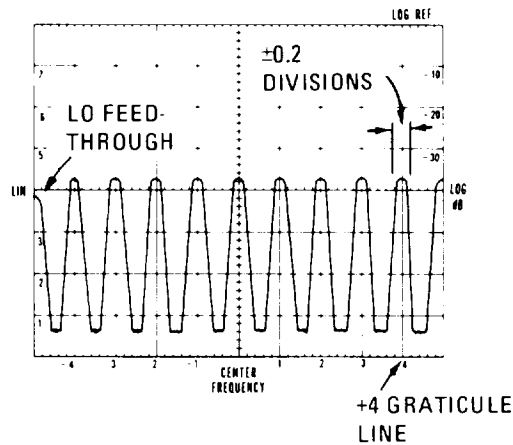

Figure 5-7. 47 MHz LO Adjustment Display

Table 5-2. Check and Adjustment Test Record

Hewlett-Packard Model 8556A Spectrum Analyzer LF Section			Test Performed by _____		
Serial No. _____			Date _____		
Para. No.	Test Description	Measurement Units	Min.	Actual	Max.
5-23	Voltage Checks				
Step: 2.	-10 Volt Supply	Vdc	-9.98	_____	-10.02
2.	+20 Volt Supply	Vdc	+19.90	_____	+20.10
4.	-12.6 Volt Supply	Vdc	-12.4	_____	-12.8
4.	+100 Volt Supply	Vdc	+99.0	_____	+101.0
6.	-12.6 Volts Filtered	Vdc	-11.0	_____	-12.0
7.	+20 Volts Isolated	Vdc	+18	_____	+22
7.	-20 Volts Isolated	Vdc	-18	_____	-22
5-24	Pre-Attenuator Adjustments				
	Pre-Attenuator (30 ± 0.10 dB):				
Step: 7.	at 3 kHz	dB	-9.8	_____	-10.2
9.	at 300 kHz	dB	0.10	_____	0.10
12.	INPUT Capacitance	pF	≈ 32	_____	
13.	Pre-Attenuator Capacitance	pF	0.5	_____	0.5
5-25	50.15 MHz Oscillator Adjustment				
Step: 3.	Signal Level	V P-P	0.9	_____	1.6
5.	Frequency	MHz	50.147	_____	50.153
5-26	Mixer Balance Adjustment				
Step: 5.	LO Feedthrough Level	dBm		_____	-80
6.	LO Feedthrough Level	dBm		_____	-80
5-27	Tracking Generator Adjustments				
Step: 5.	Flatness	mVrms	95	_____	105
6.	Max. Into Load	Vrms	1.5	_____	
7.	Flatness at Max.	mVrms	5	_____	5
5-28	Frequency Calibration Adjustment				
Step: 6.	RANGE Switch Shift	Hz		_____	150

**SECTION VI
REPLACEABLE PARTS**

6-1. INTRODUCTION

6-2. Table 6-1 is an index of reference designations and abbreviations used in Hewlett-Packard manuals.

6-3. Table 6-3 lists 8556A replaceable parts in alpha-numerical order of their reference designation.

6-4. Table 6-2 lists code number identification of part manufacturers. (Manufacturer's code and part number are supplied for each part listed in Table 6-3).

6-5.

DELETED

6-6.

6-7. To obtain a part that is not listed, include:

- a. Instrument model number.
- b. Instrument serial number.
- c. Description of the part.
- d. Function and location of the part.

Table 6-1. Reference Designators and Abbreviations used in Parts List

REFERENCE DESIGNATORS							
A	= assembly	F	= fuse	P	= plug	V	= vacuum tube.
B	= motor	FL	= Filter	Q	= transistor		neon bulb.
BT	= battery	J	= jack	R	= resistor		photocell, etc.
C	= capacitor	K	= relay	RT	= thermistor	VR	= voltage
CP	= coupler	L	= inductor	S	= switch		regulator
CR	= diode	LS	= loud speaker	T	= transformer	W	= cable
DL	= delay line	M	= meter	TB	= terminal board	X	= socket
DS	= device signaling (lamp)	MK	= microphone	TP	= test point	Y	= crystal
E	= misc electronic part	MP	= mechanical part	U	= integrated circuit	Z	= tuned cavity, network
ABBREVIATIONS							
A	= amperes	H	= henries	NIO	= normally open	RMO	= rack mount only
AFC	= automatic frequency control	HDW	= hardware	NOM	= nominal	RMS	= root-mean square
AMPL	= amplifier	HEX	= hexagonal	NPO	= negative positive	RWV	= reverse working
BFO	= beat frequency oscillator	HG	= mercury		zero (zero temperature coefficient)	voltage	
BE CU	= beryllium copper	HR	= hour(s)	NPB	= negative-positive-negative	S-B	= slow-blow
BH	= binder head	Hz	= Hertz			SCR	= screw
BP	= bandpass					SE	= selenium
BRS	= brass	IF	= intermediate freq			SECT	= section(s)
BWO	= backward wave oscillator	IMPG	= impregnated	NRFR	= not recommended for field replacement	SEMICON	= semiconductor
		INCD	= incandescent			SI	= silicon
		INCL	= include(s)			SIL	= silver
		INS	= insulation(ed)	NSR	= not separately replaceable	SL	= slide
		INT	= internal			SPG	= spring
				OBD	= order by description	SPL	= special
CCW	= counterclockwise	K	= kilo = 1000			SST	= Stainless steel
CER	= ceramic			OH	= oval head	SR	= split ring
CMO	= cabinet mount only	LH	= left hand	OX	= oxide	STL	= steel
COEF	= coefficient	LIN	= linear taper	P	peak	TA	tantalum
COM	= common	LK WASH	= lock washer	PC	= printed circuit	TD	= time delay
COMP	= composition	LOG	= logarithmic taper	PF	= picofarads = 10 ⁻¹²	TGL	= toggle
COMPL	= complete	LPF	= low pass filter	PH BRZ	= phosphor bronze	THD	= thread
CONN	= connector					TI	= titanium
CP	= cadmium plate	M	= milli = 10 ⁻³	PHL	= Phillips	TOL	= tolerance
CRT	= cathode-ray tube	MEG	= meg = 10 ⁹	PIV	= peak inverse voltage	TRIM	= trimmer
CW	= clockwise	MET FLM	= metal film			TWT	= traveling wave tube
DEPC	= deposited carbon	MET OX	= metallic oxide	PNP	= positive-negative-positive		
DR	= drive	MFR	= manufacturer				
ELECT	= electrolytic	MHZ	= mega Hertz	P/O	= part of		
ENCAP	= encapsulated	MINAT	= miniature	POLY	= polystyrene	μ	= micro 10 ⁶
EXT	= external	MOM	= momentary	PORC	= porcelain		
MOS	= metalized	POS	= position(s)	VAR	= variable	VDCW	= dc working volts
F	= farads	MTG	= mounting	POT	= potentiometer		
FH	= flat head	MY	= "mylar"	PP	= peak-to-peak		
FIL H	= fillister head			PT	= point		
FXD	= fixed	N	= nano (10 ⁻⁹)	PWV	= peak working voltage	W/	= with
		N/C	= normally closed			W	= watts
G	= giga (10 ⁹)	NE	= neon	RECT	= rectifier	WIV	= working inverse
GE	= germanium	NI PL	= nickel plate	RF	= radio frequency	WW	= wirewound
GL	= glass			RH	= round head or right hand	W/O	= without
GRD	= ground(ed)						

Table 6-2. Manufacturers' Code List

MFR NO.	MANUFACTURER NAME	ADDRESS	ZIP CODE
00000	U.S.A. COMMON	ANY SUPPLIER OF U.S.A.	
01121	ALLEN BRADLEY CO.	MILWAUKEE, WIS.	53204
01295	TEXAS INSTRUMENTS INC. SEMICONDUCTOR COMPONENTS DIV.	DALLAS, TEX.	75231
04713	MOTOROLA SEMICONDUCTOR PROD. INC.	PHOENIX, ARIZ.	85008
07263	FAIRCHILD CAMERA & INST. CORP. SEMICONDUCTOR DIV.	MOUNTAIN VIEW, CALIF.	94040
08664	BRISTOL CO. THE	WATERBURY, CONN.	06720
08717	SLOAN CO. THE	SUN VALLEY, CALIF.	91352
12574	GULTON IND. INC. DATA SYSTEM DIV.	ALBUQUERQUE, N.M.	87108
28480	HEWLETT-PACKARD COMPANY	PALO ALTO, CALIF.	94304
36196	STANWYCK COIL PROD. LTD.	HAWKSBURY ONTARIO, CANADA	
56289	SPRAGUE ELECTRIC CO.	N. ADAMS, MASS.	01247
70276	ALLEN MFG. CO.	HARTFORD, CONN.	06101
71041	BOSTON GEAR WORKS DIV N. AMERICAN ROCKWELL CORP.	QUINCY, MASS.	02171
71468	ITT CANNON ELECT. INC.	LOS ANGELES, CALIF.	90031
71593	GLOBE UNION INC. CENTRALAB DIV.	MILWAUKEE, WISC.	53201
71744	CHICAGO MINIATURE LAMP WORKS	CHICAGO, ILL.	60640
71785	CINCH MFG. CO. DIV TRW INC.	ELK GROVE VILLAGE, ILL.	
72136	ELECTRO MOTIVE MFG. CO. INC.	WILLIMANTIC, CONN.	06226
72982	ERIE TECHNOLOGICAL PROD. INC.	ERIE, PA.	16512
73734	FEDERAL SCREW PROD. INC.	CHICAGO, ILL.	60618
74970	JOHNSON E.F. CO.	WASECA, MINN.	56093
75042	INTERNATIONAL RESISTANCE CO. INC.	PHILADELPHIA, PA.	19108
75915	LITTELFUSE INC.	DES PLAINES, ILL.	60016
76530	CINCH MONADNOCK MILLS DIV. TRW INC.	CITY OF INDUSTRY, CALIF.	91746
78189	SHAKEPROOF DIV. ILLINOIS TOOL WORKS	ELGIN, ILL.	60120
78488	STACKPOLE CARBON CO.	ST. MARYS, PA.	15857
79727	CONTINENTAL-WIRT ELECTRONICS CORP.	PHILADELPHIA, PA.	19144
80131	ELECTRONIC INDUSTRIES ASSOCIATION	WASHINGTON D.C.	20006
82142	AIRCO SPEER ELECT. COMP.	DU BOIS, PA.	15801
91506	AUGAT INC.	ATTLEBORO, MASS.	02703
93332	SYLVANIA ELECTRIC PROD. INC. SEMICONDUCTOR DIV.	WOBBURN, MASS.	01801
98291	SEAELECTRO CORP.	MAMARONECK, N.Y.	10544
98978	INTERNATIONAL ELECT. RESEARCH CORP.	BURBANK, CALIF.	91502
99800	DELEVAN ELECTRONICS CORP.	E. AURORA, N.Y.	14052

Table 6-3. Replaceable Parts

Reference Designation	HP Part Number	Qty	Description	Mfr Code	Mfr Part Number
A1	08556-60026	1	SWITCH ASSY:BAND WIDTH	28480	08556-60026
A1CR1	1901-0025	3	DIODE:SILICON 100MA/1V	07263	FD 2387
A1R1	0757-0274	1	R:FXD MET FLM 1.21K OHM 1% 1/8W	28480	0757-0274
A1R2	0757-0465	5	R:FXD MET FLM 100K OHM 1% 1/8W	28480	0757-0465
A1R3	0698-3453	1	R:FXD MET FLM 196K OHM 1% 1/8W	28480	0698-3453
A1R4	0698-3161	2	R:FXD MET FLM 38.3K OHM 1% 1/8W	28480	0698-3161
A1R5	0698-4507	1	R:FXD MET FLM 76.8K OHM 1% 1/8W	28480	0698-4507
A1R6	0698-3161		R:FXD MET ELM 38.3K OHM 1% 1/8W	28480	0698-3161
A1R7	0698-4534	2	R:FXD MET FLM 309K OHM 1% 1/8W	28480	0698-4534
A1R8	0698-4521	2	R:FXD MET FLM 154K OHM 1% 1/8W	28480	0698-4521
A1R9	0698-4534		R:FXD MET ELM 309K O M 12 1/8W	28480	0698-4534
A1R10	0698-4521		R:FXD MET FLM 154K OHM 1% 1/8W	28480	0698-4521
A1R11	0757-0458	1	R:FXD MET FLM 51.1K OHM 1% 1/8W	28480	0757-0458
A1R12	0698-3148	1	R:FXD FLM 102K OHM 1% 1/8W	28480	0698-3148
A1R13	0698-4487	1	R:FXD FLM 25.5K OHM 1% 1/8W	28480	0698-4487
A1R14	0698-3157	3	RFXD MET FLM 19.6K OHM 1% 1/8W	28480	0698-3157
A1S1	3100-3012	1	SWITCH:ROTARY 7 POSITION	2848C	3100-3012
A2	08556-60027	1	SWITCH ASSY:SCANWIDTH	28480	08556-60027
A2R1	0698-6296	1	R:FXD MET FLM 20.00 OHM 0.25% 1/8W	28480	0698-6296
A2R2	0698-7533	2	R:FXD FLM 30 OHM 0.25% 1/9W	2848C	0698-7533
A2R3	0698-4190	2	R:FXD MET FLM 50 OHM 0.25% 1/8W	28480	0698-4190
A2R4	0698-7888	1	R:FXD FLP 22.2 OHM 0.25% 1/8W	28480	0698-7888
A2R5	0698-7532	1	R:FXD FLM 100 OHM 0.25% 1/8W	28480	0698-7532
A2R6	0698-7533		R:FXD FLM 30 OHM 0.25% 1/8W	28480	0698-7533
A2R7	0698-4190		R:FXD MET FLM 50 OHM 0.25% 1/8W	28480	0698-4190
A2R8	0698-6299	1	R:FXD MET FLM 100.40 OHM 0.25% 1/8W	28480	0698-6299
A2R9	0698-7916	1	R:FXD FLM 301.2 OHM 0.25% 1/8W	28480	0698-7916
A2R10	0698-6315	1	R:FXD MET FLM 503.1 OHM 0.25% 1/8W	28480	0698-6315
A2R11	0698-6302	1	R:FXD MET FLM 995 OHM 0.25% 1/8W	28480	0698-6302
A2R12	0757-0488	4	R:FXD MET FLM 909K OHM 1% 1/8W	28480	0757-0488
A2R13	0757-0488		R:FXD MET FLM 909K OHM 1% 1/8W	28480	0757-0488
A2R14	0757-0488		R:FXD MET FLM 909K OHM 1% 1/8W	28480	0757-0488
A2R15	0757-0488		R:FXD MET FLM 909K OHM 1% 1/8W	28480	0757-0488
A2R16	0698-3260	6	R:EXD MET FLM 464K OHM 1% 1/8W	28480	0698-3260
A2R17	0698-3260		R:FXD MET FLM 464K OHM 1% 1/8W	28480	0698-3260
A2R18	0698-3260		R:FXD MET FLM 464K OHM 1% 1/8W	28480	0698-3260
A2R19	0698-3260		R:FXD MET FLM 464K OHM 1% 1/8W	28480	0698-3260
A2R20	0698-3260		R:FXD MET FLM 464K OHM 1% 1/8W	28480	0698-3260
A2R21	0698-3260		R:FXD MET FLM 464K OHM 1% 1/8W	28480	0698-3260
A2R22	0698-3271	2	R:FXD MET FLM 115K OHM 1% 1/8W	28480	0698-3271
A2R23	0698-3271		R:FXD MET FLM 115K OHM 1% 1/8W	28480	0688-3271
A2S1	3100-3011	1	SWITCH:ROTARY DUAL CONCENTRIC PART OF S1	28480	3100-3011
A2S2					
A3	08556-60028	1	SWITCH ASSY:INPUT LEVEL	28480	08556-60028
A3MP1	5040-0218	1	COUPLER:SWITCH SHAFT	28480	5040-0218
A3R1	0698-7915	1	R:FXD FLM 900.0 OHM 0.25% 1/8W	28480	0698-7915
A3R2	0698-7912	1	R:FXD FLM 111.1 OHM 0.25% 1/8W	2848C	0698-7912
A3R3	0698-7914	1	R:FXD FLM 216.2 OHM 0.25% 1/8W	28480	0698-7914
A3R4	0698-7913	1	R:FXD FLM 146.3 OHM 0.25% 1/8W	28480	0698-7913
A3R5	2100-3107	1	R:VAR CERMET 10K OHM 1%02 1000LOG 1W	28480	2100-3107
A3R6	0757-0798	1	R:FXD MET FLM 110 OHM 1% 1/2W	28480	0757-0798
A3S1	3100-3010	1	SWITCH:ROTARY 6 POSITION	28480	3100-3010
A3W1	08556-60011	1	CABLE ASSY:INPUT AMPLIFIER	28480	08556-60011
A3W2	08556-60010	1	CABLE ASSY:INPUT CONVERTER	28480	08556-60010
A3W3	08556-60014	1	CABLE ASSY:TG LEVEL	28480	08556-60014
A4			NOT ASSIGNED		
A5	08556-60005	1	BOARD ASSY:PRE-ATTENUATOR-AM	28480	28556-60005
A5	08556-29002	5	HOUSING:SHIELD	28480	08556-29002
A5	08556-20018	2	SHIELD:HOUSING	28480	08556-20018
A5C1	0180-0094	4	C:FXD ELECT 100 UF +75-102 25VDCW	56289	300107G0250D2-DSM
A5C2	0160-0127	5	C:FXD CER 1.0 UP 20% 25VDCW	56289	5013CS-CML
A5C3	0180-0094		C:FXD ELECT 100 UF .75-105% 25VDCW	56289	3001070025002-DSM
A5C4	0160-0127		R:FXD CER 1.0 UF 202 25VDCW	56289	5013CS-CML
A8C5	0180-2376	1	C: FXD AL ELECT 3.5 UF +50-10% 200DCW	56289	390257
A5C6	0121-0105	2	C:VAR CER 9-35 NPO	28480	0121-0105
A5C7	0121-0105		C:VAR CER 9-35 PF NPO	28480	0121-0105
A5C8	C180-1714	1	C:FXD ELECT 330 UF 102 6VDCW	28480	0180-1714
A5C9	0180-0291	3	C:FXD ELECT 1.0 UF 10 35V0CW	56289	150010539035A2-DYS
A5C10	0160-2261	1	C:FXD CER 15 PF 5% 500V0CW	72982	301-NPE-15 PF
A5C11	0160-2257	1	C:FXD CER 10 PF 5% 500V0CW	72982	301-000-CDH0-100J
A5C12	0180-1907	2	C:FXD AL ELECT 560 UF +75-102 6VDCW	56289	300567G006DH2-DSM
A5C13	0180-1819	1	C:FXD ELECT 100 UF .75-102 50V0CW	2848C	0180-1819
A5CR1	1901-0025		DIODE:SILICON 100MA/1V	07263	FD 2387
A5CR2	1901-0025		DIODE:SILICON 100MA/1V	07263	FD 2387
A5CR3	1901-0376	2	DIODE:SILICON 35V	28480	1901-0376

See introduction to this section for ordering information

Table 6-3. Replaceable Parts

Reference Designation	HP Part Number	Qty	Description	Mfr Code	Mfr Part Number
A5CR4	1901-0376		DIODE:SILICON 35V	28480	1901-0376
A5CR5	1902-0064	2	DIODE BREAKDOWN:7.5V	28480	1902-0064
A5CR6	1902-0064		DIODE BREA KDOWN:7.5V	28480	1902-0064
A5J1	1250-1195	5	CONNECTOR:RF SUB-MINIATURE SERIES	98291	52-053-0000
A5J2	1250-1195		CONNECTOR:RF SUB-MINIATURE SERIES	98291	52-053-0000
A5K1	0490-1011	1	RELAY:24V 125C	28480	0490-1011
A5AK2	0490-0965	1	RELAY:REED 12VDC 0.5A	28480	0490-0965
A5Q1	1853-0050	5	TSTR:SI PNP	28460	1853-0050
A5Q2	1853-0050		TSTR:SI PNP	28480	1853-0050
A5Q3	1853-0050		TSTR:SI PNP	28480	1853-0050
A5Q4	1855-0372	1	TSTR:FET SI N-CHANNEL	28480	1855-0372
A5R1	0757-0401	9	R:FXD MET FLM 100 OHM 1% 1/8W	28480	0757-0401
A5R2	0757-0401		R:FXD MET FLM 100 OHM.1% 1/8W	28480	0757-0401
A5R3	0698-7922	1	R:FXD FL 968K OHM 0.25% 1/8W	28480	0698-7922
A5R4	0698-7917	1	R:FXD FLM 32.6K OHM 0.25% 1/8W	28480	0698-7917
A5R5	0675-1011	1	R:FXD COMP 100 OHM 1% 1/8W	01121	BB-1011
A5R6	0157-0344	1	R:FXD MET FLM 1.00 NEG OHM 1% 1/4W	28480	0757-0344
A5R7	0698-7920	1	R:FXD FL126.6 OHM 0.25% 1/8W	28480	0698-7920
A5R8	0698-7919		R:FXD FLM 1516.0 OHM 0.251 1/8W	28480	0698-7919
A5R9	0698-7918	1	R:FXD FLM 798.0 OHM 0.25% 1/8W	28480	0698-7918
A5R10	0698-7921	1	R:FXD FLM 1953 OHM 0.25% 1/8W	28480	0698-7921
A5R11	0698-3150	1	R:FXD MET FLM 2.37K OHM 1% 1/8W	28480	0698-3150
ASR12	0757-0442		R:FXD MET FLM 110.0K OHM 1% 1/8W	28480	0757-0442
A5R13	0698-3162	1	R:FXD MET FLM 46.4K OHM 1% 1/8W	28480	0698-3162
A5814	0698-3455	3	R:FXD MET FLM 261K OHM 1% 1/8W	28480	0698-3455
A5R15	0698-7967	1	R:FXD FL 2.5K OHM 0.25% 1/8W	28480	0698-7967
A5R16	0698-3455		R:FXD MET FLM 261K OHM 1% 1/8W	28480	0698-3455
A5R17	0698-3155	1	R:FXD MET FLM 4.64K OHM 1% 1/8W	28480	0698-3155
A5R18	0757-0444	1	R:FXD MET FLM 12.1K OHM 1% 1/8W	28480	0757-0444
A581R19	0757-0290	4	R:FXD MET FLM 6.19K OHM.1% 1/8W	28480	0757-0290
A5R20	0757-0401		R:FXD MET FLM 100 OHM 1% 1/8W	28480	0757-0401
A5TP1	0340-0038	4	FEEDTHRU:TERMINAL	28480	0340-0038
A5P1	0340-0039	4	INSULATOR:BUSHING	28480	0340-0039
A5TP2	0340-0038		FEEDTHRU:TERMINAL	28480	0340-0038
A5TP2	0340-0039		INSULATOR:BUSHING	28480	0340-0039
A6	08556-60006	1	BOARD ASSY: FREQUENCY CONVERTER	28480	08556-60006
A6	08556-20002		HOUSING: SHIELD	28480	08556-20002
A6C1	0160-3878	2	C: FXD CER 0.001 UF 20% 75VDCW	12574	SSM-001-98
A6C2	0160-3878		C:FXD CER 0.001 UF 20% 75VDCW	12574	SSM-001-98
A6C3	0180-0197	4	C:FXD ELECT 2.2 UF 10% 20VDCW	56289	1500225X9020A2-DYS
A6C4	0180-0197		C:FXD ELECT 2.2 UF 10% 20VDCW	56289	1500225X9020A2-DYS
46C5	0160-3456	23	C:FXD CER .001 UF 10% 250VDC	56289	C067F251F102KE12-CDH
46C6	0180-1907		C:FXD AL ELECT 560 UF .75-101 6VDCW	56289	30D567G006DH2-DSN
A6C7	0160-3449	1	C:FXD CER 2000 PF 10% 250VDCW	56289	C067B251F202KS25-CDH
A6C8	0160-2130	2	C:FXD MICA 865 PF 11	28480	0160-2130
A6C9	0160-0300	1	C:FXD MY 0.0027 UF 200VDCW	56289	192P27292-PTS
A6C10	0160-2130		C:FXD MICA 865 PF 12	28480	0160-2130
A6C11	0160-2244	1	C:FXD CER 3.0+/1-0.25 PF 500VDCW	28480	0160-2244
A6C12	0121-0453	1	C:VAR AIR 1.3-5.4 PF 250V0C	74970	187-103-105
A6C13	0160-2238	1	C:FXD CER 1.5 PF 500VDC0	72982	301-000-C0K0-159C
A6C14	0160-3456		C:FXD CER .001 UF 010 250VDCW	56289	C067F251F102KE12-CDH
A6C15	0160-3456		C:FXD CER .001 UF 101 250VDCW	56289	C067F251F102KE12-CDH
A6C16	0160-3456		C:FXD CER .001 UF 101 250VDCW	56289	C067F251F102KE12-CDH
A6C17	0160-2206	1	C:FXD MICA 160 PF 5%	28480	0160-2206
A6C18	0160-2307	1	C:FXD MICA 47 PF 5%	28480	0160-2307
A6C19	0160-3456		C:FXD CER .001 UF 102 250VDCW	56289	C067F251F102KE12-CDH
A6C20	0160-3456		C:FXD CER .001 UF 010 250VDCW	56289	C067F251F012KE12-CDH
A6C21	0160-3456		C:FXD CER .001 UF 101 250VDCW	56289	C067F2S F102KE12- CDH
A6C22	0121-0479	1	C:VAR CER 1.7-11.0 PF 250VDC	74970	187-0106-105
A6C23	0160-2262	1	C:FXD CER 16 PF 5% 500VDCW	72982	301-000 COKO 160J
A6C24	0160-3456		C:FXD CER .001 UF 101 250VDCW	56289	C067F251F102KE12-CDH
A6C25	0160-3456		C:FXD CER .001 UF 102 250VDCW	56289	C067F251F102KE12-CDH
A6C26	0160-3456		C:FXD CER .001 UF 102 250VDCW	56289	C067F251F12KEZ12-CDH
A6C27	0160-3456		C:FXD CER .001 UF 101 250VDCW	56289	C067F251F102KE12-CDH
A6CR1	5080-0272	8	DIODE:SILICON MATCHED QUAD (NSR)	28480	5080-0272
A6CR2	5080-0272		DIODE:SILICON MATCHED QUAD (NSR)	28480	5080-0272
A6CR3	5080-0272		DIODE:SILICON MATCHED QUAD (NSR)	28480	5080-0272
A6CR4	5080-0272		DIODE:SILICON MATCHED QUAD (NSR)	28480	5080-0272
A6CR5	1902-3104	1	DIODE:BREAKDOWN 5.62V 5%	04713	5110939-110
A6J1	1250-1195		CONNECTOR:RF SUB-MINIATURE SERIES	98291	52-053-0000
A6J2	08443-20011	3	CONNECTOR:RECESS	28480	08443-20011
A6J2	1250-1194	3	CONNECTOR:RF UJLKHEAD RECEPTACLE	91291	52-045-4610
A6J2	2950-0043	3	NUT:HEX 3/8-32 x 7/16 X 3/32	00000	OBD
A6J3	08443-20011		CONNECTOR:RECESS	28480	08443-20011
A6J3	1250-1194		CONNECTOR:RF BULKHEAD RECEPTACLE	98291	52-045-4610

See introduction to this section for ordering information

Table 6-3. Replaceable Parts

Reference Designation	HP Part Number	Qty	Description	Mfr Code	Mfr Part Number
A6J3	2950-0043		NUTIHEX 3/8-32 X 7/16 X 3/32	00000	0BD
A6L1	9140-0158	1	COIL:FXD RF 1 UH 10%	99800	1025-20
A6L2	9140-0237	6	COIL:FXD 200 UH 5%	28480	9140-0237
A6L3	9140-0237		COIL:FXD 200 UH 5%	28480	9140-0237
A6L4	9100-2255	2	COIL/CHOKE 0.47 UH 10%	28480	9100-2255
A6L5	9100-2255		COIL/CHOKE 0.47 UH 10%	28480	9100-2255
A6L6	9140-0179	2	COIL/CHOKE 22.0 UH 10%	28480	9140-0179
A6L7	9140-0179		COIL/CHOKE 22.0 UH 10%	28480	9140-0179
A6L8	9100-1616	1	COIL/CHOKE 1.50 UH 10%	99800	1537-16
A6L9	9100-0368	1	COIL FXD 0.33 UH 10%	36196	1A-3303M
A6Q1	1854-0019	5	TSTR:SI MPN	28480	1854-0019
A6Q2	1854-0019		TSTR:SI NPN	28480	1854-0019
A6Q3	1854-0019		TSTR SI NPN	28480	1854-0019
A6Q3	1205-0037	2	HEAT SINK:TRANSISTOR	28480	1205-0037
A6Q4	1854-0247	1	TSTR:SI MPN	28480	1854-0247
A6R1	0757-0465		R:FXD NET FLM 100K OHM 1% 1/8W	28480	0157-0465
A6R2	0698-3443	3	R:FXD MET FLM 287 OHM 1% 1/8W	28480	0698-3443
A6R3	0757-0346	4	R:FXD MET FLM 10 OHM 1% 1/8W	28480	0757-0346
A6R4	0757-0346		R:FXD MET FLM 10 OHM 1% 1/8W	28480	0757-0346
A6R5	2100-2632	1	R4VAR FLM 100 OHM 1% LIN 1/2W	28480	2100-2632
A6R6	0757-0400	2	R:FXD NET FLM 90.9 OHM 1% 1/8B	28480	0757-0400
A6R7	0757-0400		R:FXD MET FLM 90.9 OHM 1% 1/8W	28480	0757-0400
A6R8	0757-0401		R:FXD NET FLM 100 OHM 1% 1/8W	28480	0757-0401
A6R9	0757-0401		R:FXD POET FLM 100 OHM 1% 1/8W	28480	0757-0401
A6R10	0698-0082	2	R:FXD MET FLM 464 OHM 1% 1/8W	28480	0698-0082
A6R11	0757-0401		R:FXD NET FLM 100 OHM 1% 1/8W	28480	0757-0401
A6R12	0698-0083	8	R:FXD MET FLM 1.96K OHM 1% 1/8W	28480	0698-0083
A6R13	0757-0317	2	R:FXD MET FLM 1.33K OHM 1% 1/8W	28480	0757-0317
A6R14	0757-0317		R:FXD MET FLM 1.33K OHM 1% 1/8W	28480	0757-0317
A6R15	0757-0346		R:FXD MET FLM 10 OHM 1% 1/8W	28480	0757-0346
A6R16	0698-3431	2	R:FXD MET FLM 23.7 OHM 1% 1/8W	28480	0698-3431
A6R17	0757-0198	1	R:FXD MET FLM 100 OHM 1% 1/2W	28480	0757-0198
A6R18	0757-0346		R:FXD NET FLM 10 OHM 1% 1/8W	28480	0757-0346
A6R19	0757-0394	2	R:FXD MET FLM 51.1 OHM 1% 1/8W	28480	0757-0394
A6R20	0698-3443		R:FXD MET FLM 287 OHM 1% 1/8W	28480	0698-3443
A6R21	0757-0394		R:FXD MET FLM 51.1 OHM 1% 1/8W	28480	0757-0394
A6R22	0698-3441	3	R:FXD NET FLM 215 OHM 1% 1/8W	28480	0698-3441
A6R23	0757-1094	3	R:FXD MET FLM 1.47K OHM 1% 1/8W	28480	0757-1094
A6824	0757-1094		R:FXD MET FLM 1.47K OHM 1% 1/8W	28480	0757-1094
A6R25	0757-0397	2	R:FXD NET FLM 68.1 OHM 1% 1/8W	28480	0757-0397
A6R26	0698-3429	3	R:FXD MET FLM 19.6 OHM 1% 1/8W	28480	0698-3429
A6R27	0757-0799	1	R:FXD MET FLM 121 OHM 1% 1/8W	28480	0757-0799
A6R28	0698-0082		R:FXD MET FLM 464 OHM 1% 1/8W	28480	0698-0082
A6T1	08556-80001	1	TRANSFORMER:TURN	28480	08556-80001
A6T2	08556-80003	2	TRANSFORMER IRF	28480	08556-80003
A6T3	08556-80003		TRANSFORMER:RF	28480	08556-80003
A6Y1	0410-0427	1	CRYSTAL:QUARTZ 50.150 MHZ	28480	0410-0427
A7	08556-60007	1	BOARD ASSY, FREQUENCY CONTROL	28480	08556-60007
A7	08556-20002		HOUSING:SHIELD	28480	09556-20002
A7C1	0160-2055	17	C:FXD CER 0.01 UF +80-20% 100VDCW	56289	C023F101F103ZS22-CDH
A7C2	0160-2055		C:FXD CER 0.01 UF +80-20% 100VDCW	56289	C023F101F103ZS22-CDH
A7C3	0160-3456		C:FXD CER .001 UF 10% 250VDCW	56289	C067F251F102KE12-CDH
A7C4	0160-2055		C:FXD CER 0.01 UF +80-20% 1001DCW	56289	C023F0F10103ZS22-CDH
A7C5	0160-2055		C:FXD CER 0.01 UF +80-20% 100VDCW	56289	C023F101F103ZS22-CDH
A7C6	0160-2055		C:FXD CER 0.01 UF+ 80-201 100V81W	56289	C023F101F103ZS22-CDH
A7C7	0160-2055		C:FXD CER 0.01 UF +80-202 100VDCW	56289	C023F1011F03ZS22-CDH
A7C8	0180-0197		C:FXD ELECT 2.2 UF 10% 20VDCW	56289	150D225X9020 A2-DYS
A7C9	0160-3060	2	C:FXD CER 0.1 UF 20% 25VD00	56289	3C42A-CML
A7C10	0180-0116	4	C:FXD ELECT 6.8 UF 10% 35VDC0	56289	150D685X903582-DYS
A7C11	0180-0116		C:FXD ELECT 6.8 UF 10% 35VD00W	56289	150D685X9035B2-DYS
A7CR1	1902-3106	1	DIODE BREAKDOWN SILICON 5.76V	29480	1902-3106
A7L1	9140-0118	2	COIL: FXD 500 UH 5%	28480	9140-0118
A7L2	9140-0118		COIL: FXD 500 UN 5%	28480	9140-0118
A7Q1	1853-0001	1	TSTR:SI PNP(SELECTED FROM 2N11321)	28480	1853-0001
A7R1	0757-0419	2	R:FXD NET FLM 681 OHM 1% 1/8W	28480	0757-0419
A7R2	0757-0442	4	R:FXD NET FLM 0.00K OHM 1% 1/8W	28480	0757-0442
A7R3	0757-1094		R:FXD MET FLM 1.47K OHM 1% 1/8W	28480	0757-1094
A7R4	0157-0419		R:FXD MET FLM 681 OHM 1% 1/8W	28480	0757-0419
A7R5	0757-0401		R:FXD MET FLM 100 OHM 1% 1/8W	28480	0757-0401
A7R6	0698-3615	1	R:FXD MET OX 47 OHM 5% 2W	28480	0698-3615
A7R7	0698-3154	2	R:FXD MET FLM 4.22K OHM 1% 1/8W	28480	0698-3154
A7R8	0683-1555	1	R:FXD COUP 1.5 NEG OHM 5% 1/4W	01121	CB 1555
A7R9	0698-7996	1	R:FXD FLM 555.5 OHM 0.25% 1/8W	28480	0698-7996
A7R10	0698-3237	4	R:FXD FLM 5K OHM 0.25% 1/8W	28480	0698-3237
A7R11	0698-3154		R:FXD MET FLM 4.22K OHM 1% 1/8W	28480	0698-3154

See introduction to this section for ordering information

Table 6-3. Replaceable Parts

Reference Designation	HP Part Number	Qty	Description	Mfr Code	Mfr Part Number
A7R12	0698-3455		R:FXD MET FLM 261K OHM 1% 1/8W	28480	0698-3455
A1R13	2100-1762	1	R:VAR MW 20K 5% 1W	75042	CT-106-4
A7R14	0698-3236	1	R:FXD FLM 5K OHM 0.25% 1/8W	28480	0698-3236
A7R15	0698-3237		R:FXD FLM 5K OHM 0.25% 1/8W	28480	0698-3237
A7R16	0698-3237		R:FXD FLM 5K OHM 0.25% 1/8W	28480	0698-3237
A7R17	0698-3193	2	R:FXD FLM 10K OHM 0.25% 1/8W	28480	0698-3193
A7R18	0698-3193		R:FXD FLM 10K OHM 0.25% 1/8W	28480	0698-3193
A7R19	0698-3237		R:FXD FLM 5K OHM 0.25% 1/8W	28480	0698-3237
A7TP1	0340-0038		FEEDTHRU:TERMINAL	28480	0340-0038
A7TP1	0340-0039		INSULATOR:BUSHING	28480	0340-0039
A7TP2	0340-0038		FEEDTHRU:TERMINAL	28480	0340-0038
AT7P2	0340-0039		INSULATOR:BUSHING	28480	0340-0039
A7U1	1820-0055	2	IC:TTL DECADE COUNTER	01295	SN4356
A7U2	1820-0055		IC:TTL DECADE COUNTER	01295	SN4356
A7U3	1820-0069	1	IC:TTL DUAL 4-1NPT POS HAND GATE	01295	SN4344
A7U4	1826-0013	3	IC:LINEAR	28480	1826-0013
A7U5	1826-0013		IC:LINEAR	28480	1826-0013
A7U6	1820-0076	1	C:TTL DUAL MASTER/SLAVE FF	01295	SN4355
A7U7	1820-0054	1	C:TTL QUAD 2-INPUT NAND GATE	01295	SN4342
A7U8	1826-0013		C:LINEAR	28480	1826-0013
A8	08556-60008	1	BOARD ASSY:TG OUTPUT	28480	08556-60008
A8	08556-20002		HOUSING:SHIELD	28480	08556-20002
A8C1	0160-2055		C:FXD CER 0.01 UF 80-20% 100VDCW	56289	C023F101F 103ZS22-CDH
A8C2	0180-0094		C:FXD ELECT 100 UF +75-10% 25VDCM	56289	30D107G025002-OSM
A8C3	0180-0291		C:FXD ELECT 1.0 UF 10% 35VDCW	56289	150D105X9035A2-DYS
A8C4	0180-0291		C:FXD ELECT 1.0 UF 10% 35VDCW	56289	150D105X9035A2-DYS
A8C5	0180-1746	2	C:FXD ELECT 15 UF 10% 20VDCW	28480	0180-1746
A8C6	0160-3823	1	C:FXD POLY 0.0068 UF 5% 200VDCW	56289	192P68252E
A8C7	0160-2415	1	C:FXD MY 0.0082 UF 5% 200VDCW	28480	0160-2415
A8C8	0180-2338	1	C:FXD TANT. 650 UF 20% 20VDCW	56289	109D65710X020T2-DYP
A8C9	0160-2204	1	C:FXD MICA 100PF 5%	72136	ROM12F101J3C
A8C10	0160-2254	1	C:FXD CER 7.5 PF 500VDCW	72982	301-000-COHO-759C
A8C11	0180-0094		C:FXD ELECT 100 UF +75-10% 25VDCW	56289	3001070025002-DSM
A8CR1	1910-0016	3	DIODE:GERMANIUM 100MA/0.85V 60PIV	93332	D2361
A8CR2	1910-0016		DIODE:GERMANIUM 100MA/0.85V 60PIV	93332	D2361
A8CR3	1910-001	6	DIODE:GERMANIUM 100MA/0.85V 60PIV	93332	D2361
A8CR4	1901-0040	9	DIODE:SILICON 30NA 30V	07263	FDG1088
A8J1	1250-1195		CONNECTOR:RF SUB-MINIATURE SERIES	98291	52-053-0000
A8J2	1250-1195		CONNECTOR:RF SUB-MINIATURE SERIES	98291	52-053-0000
A8L1	9140-0237		COIL:FXD 200 UH 5%	28480	9140-0237
A8L2	9140-0237		COIL:FXD 200 UH 5%	28480	9140-0237
A8L3	9100-2463	1	COIL/CHOKE 6.8 UH 3%	82142	4435-2H
A8L4	9100-3309	1	COIL:24 UH 3%	28480	9100-3309
A8Q1	1854-0404	5	TSTR:SI NPN	28480	1854-0404
A8Q2	1854-0404		TSTR:SI NPN	28480	1854-0404
A8Q3	1853-0007	1	TSTR:SI PNP	80131	2N3251
A8Q4	1854-0404		TSTR:SI NPN	28480	1854-0404
A8Q5	1854-0404		TSTR:SI NPN	28480	1854-0404
A8Q6	1854-0053	1	TSTR:SI NPN	80131	2N2218
A8Q6	1205-0011	1	HEAT DISSIPATOR:FOR TO-5 AND TO70-9 CASE	98978	TXBF-032-025B
A8R1	0757-0280	3	R:FXD NET FLM 1K OHM 1% 1/8W	28480	0757-0280
A8R2	0757-0316	2	R:FXD MET FLM 42.2 OHM 1% 1/8W	28480	0757-0316
A8R3	0698-3441		R:FXD MET FLM 215 OHM 1% 1/8W	28480	0698-3441
A8R4	0757-0442		R:FXD MET FLM 10.0K OHM 1% 1/8M	28480	0757-0442
A8R5	0757-0290		R:FXOD NET FLM 6.19K OHM 1% 1/8W	28480	0757-0290
A8R6	0698-3441		R:FXD MET FLM 215 OHM 1% 1/8W	28480	0698-3441
A8R7	0757-0316		R:FXD MET FLM 42.2 OHM 1% 1/8W	28480	0757-0316
A8R8	0757-0418	2	R:FXD MET FLM 619 OHM 1% 1/8W	28480	0757-0418
A8R9	2100-1757	1	R:VAR WW 500 OHM 5% TYPE V 1/8W	28480	2100-1757
A8R10	0757-0290		R:FXD MET FLM 6.19K OHM 1% 1/8W	28480	0757-0290
A8R11	0157-0290		R:FXD MET FLM 6.19K OHM 1% 1/8W	28480	0757-0290
A8R12	0757-0401		R:FXD MET FLM 100 OHM 1% 1/8W	28480	0757-0401
A8R13	0757-0442		R:FXD MET FLM 10.0K OHM 1% 1/8W	28480	0757-0442
A8R14	0757-0442		R:FXD NET FLMN 10.0K OHM 1% 1/8W	28480	0757-0442
A8R15	0757-0418		R:FXD MET FL 619 OHM 1% 1/8W	28480	0751-0418
A8R16	0757-0280		R:FXD MET FLM 1% OHM 1% 1/8W	28480	0757-0280
A8R17	0698-3429		R:FXD MET FLM 19.6 OHM 1% 1/8W	28480	0698-3429
A8R18	0757-0158	1	R:FXD NET FLM 619 OHM 1% 1/8W	28480	0757-0158
A8R19	0757-1100	1	R:FXD FLM 600 OHM 1% 1/8W	28480	0757-1100
A8R20	0757-0460	1	R:FXD MET FLM 61.9K OHM 1% 1/8W	28480	0757-0460
A8R21	0757-0280		R:FXD MET FLMN K OHM 1% 1/8W	28480	0757-0280
A8	08556-00020	1	INSULATOR:3 MHZ OSCILLATOR	28480	08556-00020
A8	08556-00021	1	COVER:3 MHZ OSCILLATOR	28480	08556-00021
A8A1	08556-60029	1	BOARD ASSY:3 MHZ OSCILLATOR	28480	08556-60029
A8A1C1	0180-0197		C:FXD ELECT 2.2 UF 101 20VDCM	56289	150D225X9020A2-DYS

See introduction to this section for ordering information

Table 6-3. Replaceable Parts

Reference Designation	HP Part Number	Qty	Description	Mfr Code	Mfr Part Number
A8A1C2	0160-2266	2	C:FXD CER 24 PF 5% 500VDCW	72982	301-000-COGO-240J
A8A1C3	0160-2055		C:FXD CER 0.01 UF +80-20% 100VDCW	56289	C023F101F103Z22-CDH
A8A1C4	0160-2055		C:FXD CER 0.01 UF +80-20% 100VDCW	56289	C023F101F103Z22-CDH
A8A1C5	0160-2055		C:FXD CER 0.01 UF +80-20% 100VDCW	56289	C023F101F103Z22-CDH
A8A1C6	0160-2055		C:FXD CER 0.01 UF +80-20% 100VDCW	56289	C023F101F103Z22-CDH
A8A1C7	0160-2055		C:FXD CER 0.01 UF +80-20% 100VDCW	56289	C023F101F103Z22-CDH
A8A1C8	0160-2247	1	C:FXD CER 3.9 PF 500VDCW	72982	301-NPO-3.9 PF
A8A1CR1	5080-0272		DIODE:SILICON MATCHED QUAD (NSR)	28480	10534-8560
A8A1CR2	5080-0272		DIOOE:SILICON MATCHED QUAD (NSR)	28480	10534-8560
A8A1CR3	5080-0272		DIODE:SILICON MATCHED QUAD (NSR)	28480	10534-8960
A8A1CR4	5080-0272		DIODE:SILICON MA TCHED QUAD (NSR)	28480	10534-8560
A8A1CR5	1901-0040		DIODE:SILICON 30MA 30WV	07263	FDG1088
A8A1CR6	1901-0518	1	DIODE:HOT CARRIER	28480	1901-0518
A8A1CR7	0122-0049	1	DIODE TUNING:90 PF 10%	28480	0122-0049
A8A1CR8	1901-0040		DIODE:SILICON 30MA 30WV	07263	FDG1088
A8A1L1	9140-0237		COIL:FXD 200 UH 5%	28480	9140-0237
ASA1L2	9100-1636	1	COIL/CHOKE 110 UH 5%	28480	9100-1630
A8A1L3	9100-1630	1	COIL/CHOKE 51.0 UH 5%	28480	1853-0034
A8A1Q1	1853-0034	3	TSTR:SI PNP (SELECTED FROM 2N3251)	28480	1853-0034
A8A1Q2	1853-0034		TSTR:SI PNP (SELECTED FROM 2N3251)	28480	1853-0034
A8A1Q3	1853-0050		TSTR:SI PNP	28480	1853-0050
A8A1Q4	1853-0050		TSTR:SI PNP	28480	1353-0050
A8A1R1	2100-2574	1	R:VAR CERAET 500 OHM 1% 0N LIN 1/2W	28480	2100-2574
A8A1R2	0698-0085	2	R:FXD MET FLM 2.61K OHM 1% 1/8W (FACTORY SELECT)	28480	0698-0085(Replace with)
A8A1R3	0698-3440	1	R:FXD MET FLM 196 OHM 1% 1/8W	28480	0698-3440
A8A1R4	0698-0083		R:FXD MET FLM 1.96K OHM 1% 1/8W	28480	0698-0083
A861R5	0698-0083		R:FXD MET ELM 1.96K OHM 1% 1/8W	28480	0698-0083
A8A1R6	0757-0465		R:FXD MET FLM 100K OHM 1% 1/8W	28480	0157-0465
A8A1R7	0757-0438	1	R:FXD MET FLM 5.11K OHM 1% 1/8W	28480	0757-0438
A8A1R8	0698-3151		R:FXD MET FLM 2.87K OHM 1%2 1/8W	28480	0698-3151
A8A1R9	0757-0440	1	R:FXD MET FLM 7.50K OHM 1%1 1/8W	28480	0757-0440
A8A1R10	0698-0083		R:FXD MET FLM 1.96K OHM 1% 1/8W	28480	0698-0083
A8A1R11	0698-0083		R:FXD MET FLM 1.96K OHM 1% 1/8W	28480	0698-0083
A8A1R12	0698-0083		R:FXD MET FLM 1.96K OHM 1% 1/8W	28480	0698-0083
A8A1T1	08552-6044	3	TRANSFORMER:RF (5 PIN)	28480	08552-6044
A8A812	08552-6044		TRANSFORMER:RF (5 PIN)	28480	08552-6044
A81AXY1	1200-0770	1	SOCKET: CRYSTAL	91506	8000-AG-26
A8A1Y1	0410-0196	1	CRYSTAL:QUARTZ	28480	0410-0196
A9	08556-60009	1	BOARD ASSY:TG CONVERTER	28480	08556-60009
A9	08556-20002		HOUSING:SHIELD	28480	08556-20002
A9	08556-20018		SHIELD: HOUSING	28480	08556-20018
A9C1	0160-3456		C:FXD CER .001 UF 10% 250VDCW	56289	C067F251F102KE12-CDH
A9C2	0160-3060		C:FXD CER 0.1 UF 20% 25VDCW	56289	3C42A-CML
A9C3	0160-3456		C:FXD CER .001 UF 10% 250VDCW	56289	C067F251F102KE12-CDH
A9C4	0160-3456		C:FXD CER .001 UF 10% 250VDCW	56289	C067F251F102KE12-CDH
A9C5	0160-3456		C:FXD CER .001 UF 10% 250VDCW	56289	C067F251F102KE12-CDH
A9C6	0160-3456		C:FXD CER 001 UF 102 250VD00W	56289	C067F251F102KE12-CDH
A9C7	0160-3456		C:FXD CER 001 UF 102 250VDCW	56289	C067F251F102KE12-CDH
A9C8	0160-3456		C:FXD CER .001 UF 102 250VDCW	56289	C067F251F102KE12-CDH
A9C9	0160-2264	1	C:FXD CER 20 PF 5% 500VOCW	72982	301-000-COGO-200J
A9C10	0140-0210	1	C:FXD MICA 270 PF 5P	28480	0140-0210
A9C11	0160-2055		C:FXD CER 0.01 UF +80-201 100VDCW	56289	C023F101F103ZS22-CDH
A9C12	0160-3439	1	C:FXD POLY 0.039 UF 5% 200VDCW	28480	0160-3439
A9C13	0160-2055		C:FXD CER 0.01 UF +80-20% 100VDCW	56289	C023F101F103ZS22-CDH
A9C14	0140-0193	1	C:FXD MICA 82 PF 5%	28480	0140-0193
A9C15	0160-2055		C:FXD CER 0.01 UF +80-20% 100VDCW	56289	C023F101F103ZS22-CDH
A9C16	0160-2266		C:FXD CER 24 PF 5% 500VDCW	72982	301-000-COGO-240J
A9CR1	1902-3139	1	DIODE:BREAKDOWN 8.25V 5%	04713	SZ10939-158
A9CR2	1901-0050	4	DIODE:SI 200 MA AT 1V	07263	FDA 6308
A9CR3	1901-0050		DIODE:SI 200 MA AT 1V	07263	FDA 6308
A9CR4	1901-0500		DIODE:SI 200 MA AT 1V	07263	FDA 6308
A9CR5	1901-0050		DIODE:SI 200 MA AT 1V	07263	FDA 6308
A9J1	1250-1194		CONNECTOR:RF BULKHEAD RECEPTACLE	98291	52-045-4610
A9J1	08443-20011		CONNECTOR:RECESS	28480	08443-20011
A9J1	2950-0043		NUT:HEX 3/8-32 X 7/16 X 3/32	00000	0B0
A9L1	9100-1618	4	COIL:MOLDED CHOKE 5.60 UH	28480	9100-1618
A9L2	9140-0237		COIL:FXD 200 UH 5%	28480	9140-0237
A9L3	9100-2247	1	COIL:FXD RF 0.10 UH 10%	28480	9100-2247
A9L4	9140-0121	1	COIL:FXD 1.8 UH	28480	9140-0121
A9Q1	1854-0019		TSTR:SI 8PN	28480	1854-0019
A9Q2	1853-0034		TSTR:SI PNP (SELECTED FROM 2N3251)	28480	1853-0034
A9Q3	1854-0404		TSTR:SI NPN	28480	1954-0404
A9Q4	1853-0020	1	TSTR:SI PNPI SELECTED FROM 2N3702)	28480	1853-0020
A9Q5	1854-0019		TSTR:SI NPN	28480	1854-0019
A9Q5	1205-0037		HEAT SINK:TRANSISTOR	28480	1205-0037

See introduction to this section for ordering information

Table 6-3. Replaceable Parts

Reference Designation	HP Part Number	Qty	Description	Mfr Code	Mfr Part Number
A9R1	0757-0279	1	R:FXD NET FLM 3.16K OHM 1% 18W	28450	0757-0279
A9R2	0157-0397		R:FXD NET FLM 68.1 OHM 1% 1/8W	28480	0757-0397
A9R3	0757-04117	1	RFXD NET FL 562 OHM 1% 1/8W	28480	0757-0417
A9R5	0757-0276	1	R:FXD NET FL 61.9 OHM 1% 1/8W	28480	0757-0276
A9R5	0698-3429		R:FXD NET FLM 19.6 OHM 1% 1/8W	28480	0698-3429
A9R6	0757-0420	1	R:FXD MET FLM 750 OHM 1% 1/8W	28480	0757-0420
A9R7	0698-3443		R:FXD MET FLM 287 OHM 1% 1/8W	28480	0698-3443
A9R8	C698-3431		R:FXD MET FLM 23.7 OHM 1% 1/8W	28480	0698-3431
A9R9	0757-0815	1	R:FXD NET FLM 562 OHM 1% 1/8W	28480	0757-0815
A9R10	0757-0439	1	R:FXD NET FLM 6.81 K OHM 1% 1/2W		
A9R1	0698-3136	1	R:FXD NET FIN 17.8K OHM 1% 1/8W	28480	0698-3136
A9R12	0757-0422	1	R:FXD NET FLM 909 OHM 1% 1/8W	28480	0757-0422
A9R3	0757-04C3	1	RZFXD NET FLI 121 OHM 1% 1/8W	28480	0757-0403
A9R14	0757-0401		R:FXD NET FLM 100 OHM 1% 1/8W	28480	0757-0401
A9R15	0698-0083		R:FXD MET FLM 1.96K OHM 1% 1/8W	28480	0698-0083
A9R16	0698-0083		R:FXD NET FLM 1.96K OHM 1% 1/8W	28480	0698-0083
A9R11	0698-3334	1	R:FXD NET FLM 178 OHM 1% 1/2W	28480	0498-3334
A9R18	0698-4037	1	R:FIXD NET FLM 46.4 OHM 1% 1/8W	28480	0698-4037
A9T1	08556-6044		TRANSFORMER:RF (5 PIN)	28480	0855-6044
A9TP1	08443-00041	2	TEST POINT	28480	08443-00041
A9W1	08443-60064	1	CABLE ASSY	28480	08443-60064
A10	08C556-60012	1	BOARD ASSY:POWER SUPPLY	28480	08556-60012
A10	08556-00008	1	HOUSING:COVER POWER SUPPLY	28480	08556-00008
A10C1	0160-0127		C:FXD CER 1.0 UF 20% 25VDCW	56289	5C13CS-CNL
A10C2	0160-2055		C:FXD CER 0.01 UF 80-20 100VDCW	56289	C023F101F103ZS22-CDH
A10C3	0180-0116		C:FXD ELECT 6.8 UF 10% 35VDCW	56289	150D685X903582-DYS
A10C4	0180-0116		C:FXD ELECT 6.8 UF 10% 35VDCW	56289	1C500685903 582-CYS
A10C5	0160-0127		C:FXD CER 1.0 UF 20% 25VDCW	56289	5C13CS-CNL
A10C6	0160-0127		C:FXD CER 1.0 UF 20% 25VDCW	56289	5C13CS-CNL
A10CR1	1901-0040		DIODE SILICON 30MA 30WV	07263	FDG1088
A10CR2	1901-0040		DIODE:SILICON 30MA 30WV	07263	FDG1088
A01CR3	1901-0040		DIODE:SILICON 30MA 30WV	07263	FDG1088
A10CR4	1901-0040		DIODE:SILICON 30MA 30WV	07263	FDG1088
A10CR5	1901-0040		DIODE:SILICON 30MA 30WV	07263	FDG1088
A10CR6	1901-0040		DIODE SILICON 30MA 30WV	07263	FDG1088
A10F1	2110-0001	1	FUSE:1 AMP 250V	75915	312001.
A10L1	9100-1642	1	COIL/CHOKE 270.0 UF P5	28480	9100-1642
A10L2	9140-0137	2	COIL:FXD RF 1000 UH 5%	28480	9140-0137
A10L3	9140-0137		COIL:FXD RF 1000 UH 5%	28480	9140-0137
A10Q1	1853-0012	2	TSTR:SI PNP	80131	2N2904A
A10Q2	183-0012		TSTR:SI PNP	80131	2N2904A
A10R1	0698-7233	1	R:FXD FLM 750 OHM 22 1/8W	28480	0698-7233
A10R2	0757-0465		R:FXD INET FLM 100K OHM 1% 1/8W	28480	0757-0165
A10R3	0698-3157		R:FXD NET FLM 19.6K OHM 1% 1/8W	28480	0698-3157
A10R4	0698-3157		R:FXD MET FLM 19.6K OHM 1% 1/8W	28480	0698-3157
A10T1	08556-80002	1	TRANSFORMERZPOWER SUPPLY	28480	08556-80002
A10TP1	08443-00041		TEST POINT	28480	08443-00041
A10XF1	2110-0269	2	CLIP:FUSE 0.250 DIA	91506	6008-32CN
A11	C8556-60001	1	BOARD ASSY, MASTER	28480	08556-60001
A11C1	0160-0165	4	C:FXD MY 0.056 UF 10t 200VOCW	56289	192P56392-PTS
A11C2	0160-0165		C:FXD NY 0.056 UF 102 200VDCW	56289	192P56392-PTS
A11C3	0160-0165		C:FXD NY 0.056 UF 102 200VDCW	56289	192P56392-PTS
A11C4	0160-0165		C:FXD NY 0.056 UF 10 200VDCW	56289	192P56392-PTS
A11C5	0180-1746		C:FXD ELECT 15 UF 101 200DCW	28480	0180-1746
A11C6	0160-3456		C:FXD CER 001 UF 102 250VDCW	56289	C067F251F102KE12-CDH
A11C7	0160-2055		C:FXD CER 0.01 UF +80-202 10090CW	56289	C023F101F103ZS22-CDH
A11C8	0160-3456		C:FXD CER 001 UF 10 250VDCW	56289	C067F251F102KE12-CDH
A11C9	0160-3456		C:FXD CER 001 LW 10 250VDCW	56289	C067F251F102KE12-CDH
A11C10	0160-3456		C:FXD CER 001 UF 102 250V0CW	56289	C067F251F102KE12-CDH
A11L1	9140-0052	1	COIL:FXD RF 3.3 NHY	28480	9140-0052
A11L2	9100-1618		COIL:MOLDED CHOKE 5.60 UH	28480	9100-1618
A11L3	9100-1618		COIL:MOLDED CHOKE 5.60 UH	28480	9100-1618
A11L4	9100-1618		COIL:MOLDED CHOKE 5.60 UH	28480	9100-1618
A11Q1	1854-0039	1	TSTR:SI NPN	80131	2N3053
A11R1	0698-3640	1	R:FXD NET OX 18K OHM 5% 2W	28480	0698-3640
A11R2	0764-0018	1	R:FXD NET FLM 4700 OHM 5% 2W	28480	0764-0018
A1113	0698-3405	2	R:FXD NET FLM 4.22 OHM 1% 1/2W	28480	0698-3405
A11R4	0698-3346	1	R:FXD MET FLM 4.22K OHM 1% 1/2W	28480	0698-3346
A11R5	0698-3405		R:FXD MET FLM 4.22K OHM 1% 1/2W	28480	0698-3405
A11R6	0757-0465		R:FXD MET FLM 100K OHM 1% 1/8W	28480	0757-0465
A11TP1	0360-0124	3	TERMINAL:SOLDER LUG	28480	0360-0124
A11TP2	0360-0124		TERMINAL:SOLDER LUG	28480	0360-0124
A1TP3	0360-0124		TERMINAL:SOLDER LUG	28480	0360-0124
A11TA5	1251-2034	2	CONN:PC 20(2X10) CONTACTS	76530	65-7160
A11XA6	1251-1631	4	CONNECTOR:PC (1 X 10) 10 CONTACT	71785	252-10-30-310

See introduction to this section for ordering information

Table 6-3. Replaceable Parts

Reference Designation	HP Part Number	Qty	Description	Mfr Code	Mfr Part Number
A11XA7	1251-2034		CONN:PC 20(2X10) CONTACTS	76530	65-7160
A11XA8	1251-1631		CONNECTOR:PC (1 X 10) 10 CONTACT	71785	252-10-30-310
A11XA9	1251-1631		CONNECTOR:PC (1 X 10) 10 CONTACT	71785	252-10-30-310
A11XA10	1251-1631		CONNECTOR:PC (1 X 10) 10 CONTACT	71785	252-10-30-310
C1	0160-3448	1	CHASSIS PARTS		
J1			C:FXD CER 1000 PF 102 1000VDCW	56289	0067B251F102K525-CDH
J2			PART OF W1		
P2	1251-0055	1	PART OF W4		
P2	08555-00002	1	CONNECTOR:MALE 24 CONTACTS	28480	1251-0055
P3	1251-2081	1	SHIELD:CONNECTOR	28480	08555-00002
P3	08556-40001	1	CONNECTOR:R AND P 41 MALE CONTACT	71468	DDM-43W2-P
R2			SUPPORT:CONNECTOR	28480	08556-40001
S1	3101-1533		NOT ASSIGNED		
W1	08556-60024	1	SWITCH:SLIDE DP3 POS. MINIATLRE	78488	SS-93
			CABLE ASSY:UNBAL INPUT	28480	08556-60024
W2	08556-60016	1	CABLE ASSY:IF INTERFACE	28480	08556-60016
W3	08556-60015	1	CABLE ASSY:LO INTERFACE	28480	08556-60015
W4	08556-60023	1	CABLE ASSY, TG OUTPUT	28480	08556-60023
W5	08556-60017	1	CABLE ASSY:3 POSITION SWITCH	28480	08556-60017
XA11	1251-2799	1	CONNECTOR:PC (2 x 15) 30 CONTACT	71785	251-15-30-400
			NISCELLANEOUS		
	0370-0102	1	KNOB:RED BAR	28480	0370-0102
			(SCAN WIDTH)		
	0370-0114	1	KNOB:RED W/ARROW 5/8" 00 1/8" SHAFT	28480	0370-0114
			(FINE TUNE)		
	0370-0116	1	KNOB:BLACK ROUND (FREQUENCY)	28480	0370-0116
	0370-0151	1	KNOB:ROUND FOR 0.125" DIA SHAFT	28480	0370-0151
			(TG LEVEL)		
	3050-0004	2	WASHER:FIBRE .3125 OD	73734	NO. 1460
	8710-0864	1	WRENCH:HEX KEY	08664	116
	5040-0274	2	FOOT, PLUG-IN	28480	5040-0274
	08555-00017	1	COVER:BOTTOM	28480	08555-00017
	08556-00001	1	PANEL:REAR	28480	08556-00001
	08556-00012	1	COVER:TOP	28480	08556-00012
	08556-00013	1	DIAL:KNOB IF (8552 LOG RE' LEVEL)	28480	08556-00013
	08556-00014	1	DIAL:KNOB BANDWIDTH	28480	08556-00014
	08556-00015	1	DIAL:KNOB SCAN	28480	08556-00015
	08556-00016	1	DIAL:KNOB INPUT	28480	08556-00016
	08556-00022	1	SHIELD:MAGNETIC	28480	08556-00022
	110488	1	TERMINAL:50 OHM	28480	110488
	11095A	1	TERMINAL:600 OHM	28480	11095A
	11660A	1	SHUNT:TG	28480	11660A
	08556-40004	1	STANDOFF EXTRUSION	28480	08556-40004

See introduction to this section for ordering information

Table 6-3. Replaceable Parts

Reference Designation	HP Part Number	Qty	Description	Mfr Code	Mfr Part Number
1	2100-2531		FRONT PANEL PARTS R:VAR CERMET 10K OHM 20% LIN 2W (R4 FINE TUNE)	28480	2100-2531
2	2950-0006		NUT:HEX 1/4-32 THREAD	73734	9000
3	2190-0067		WASHER:LOCK FOR 1/4" HOW	28480	2190-0067
4	08553-2029	1	BUSHING:FINE TUNE POT	28480	08553-2029
5	2100-25%8	1	R:VAR CERMET 5K OHM 1%02 LIN 2W (R3 FREQUENCY)	28480	2100-2528
6	1410-0088	1	BUSHING:1/4 DIA	71041	846-2
7	2950-0001		NUT:HEX BRS NP 3/8-32 X 1/2	73734	9002
8	2190-0016		WASHER:LOCK PH BRZ NP	00000	OBD
9	2360-0133		SCREW:PAN HO POZI OR 6-32 X 1-1/4"	00000	OBD
10	2190-0007		WASHER:INT LOCK #6	28480	2190-0007
11	5020-3349	1	SHAFT:SST	28480	5020-3349
12	08553-2028	1	BUSHING:TUNING SHAFT	28480	08553-2028
13	3050-0017		WASHER:FLAT PHOS BRONZE	00000	OBD
14	08553-2039	1	SPUR GEAR:29T	28480	08553-2039
15	3030-0145		SCREW:SET 6-32 X 1/8" LG	70276	OBD
16	3030-0342		SCREW:SET 6-32 X 5/32" LG	00000	OBD
17	3030-0007		SCREW: SET SST 4-40 X 1/8"	00000	OBD
18	08553-2020	1	FLYWHEEL	28480	08553-2020
19	08553-2021	1	SHAFT:MAIN TUNING	28480	08553-2021
20	5000-0206		SPRING:WASHER	28480	5000-0206
21	1460-0299	1	WIREFORM:ANTI-BACKLASH	28480	1460-0299
22	08553-2040	1	SPUR GEAR.112T	28480	08553-2040
23	05%0-0127		SCREW:PAN HD POZI OR 2-56 X 3/16"	00000	OBD
24	08553-6034	1	GEAR AND HUB ASSY	28480	08553-2034
25	08553-2022		SPACER:GEARBOX	28480	08553-2022
26	08553-2018	1	PLATE:FRONT	28480	08553-2018
27	2420-0001		NUT:HEX ST NP 6-32 X 5/16 W/LOCKWASHER	78189	OBD
28	08556-00005	1	GUSSET:LEFT	28480	08556-00005
29	2360-0193		SCREW:PAN HD P0ZI DR 6-32 X 1/4'	00000	OBD
30	08553-2016	1	BUSHING:PANEL	28480	08553-2016
31	08553-2019	1	PLATE:REAR	28480	08553-2019
32	08553-00113	1	SPRING:WINDOW	28480	08553-00113
33	08556-40002	1	WINDOW:STATIONARY	28480	08556-40002
34	08556-40003	1	WINDOW:SLIDING	28480	08556-40003
35	08553-0016	1	SPRING:WINDOW	28480	08553-0016
36	08553-6029	1	PULLEY ASSY:LEFT	28480	08553-6C29
37	2200-0103		SCREW:SST PHH POZI DR 4-40 X 1/4"W/LK	00000	OBD
38	1450-0371	1	LENS:LAMPHOLDER, AMBER	08717	102-A (LENS)
39	1450-0153	1	LAMPHOLDER:FOR T-1 SERIES	08717	102SR
40	08556-20003	1	EXTRUSION:ENGRAVED	28480	08556-20003
41	08553-6030	1	PULLEY ASSY:RIGHT	28480	08553-6030
42	8200-0049	1	DIAL CORD	28480	8200-0049
43	1460-0195	1	SPRING:EXTENSION	28480	1460-0195
44	2360-0193		SCREW:PAN HO POZI OR 6-32 X 1/4"	00000	OBD
45	08553-4001	1	POINTER	28480	08553-4001
46	00197-47403	2	BUTTON:DETENT	28480	00197-47403
47	1460-0199	1	SPRING:EXTENSION	28480	1460-0199
48	2100-3066	2	R:VAR WW 5K OHM 5% LIN 1W (10T) CR6 ZERO ADJ)	28480	2100-3066
49	08556-00007	1	BRACKET:POT	28480	08556-00007
50	2100-2487	1	R:VAR COMP 500 OHM 202 LIN 1/2W R5 300KHZ ADJ)	28480	2100-2487
51	08556-00006	1	SUB-PANEL	28480	08556-00006
52	2360-0200		SCREW:FLAT HD POZI DR 6-32 X 1/2"	00000	OBD
53	2100-2488	1	R:VAR COMP 10K OHM 202 LIN 1/2W (R7 AMPL CAL)	28480	2100-2488
54	2140-0259	1	LAMP:INCANOESENT 12V 0.06A (DS1	71744	CM8-1099
55	2100-3066		R:VAR WW 5K OHM 5% LIN 1W (10T) (R1 TRACK ADJ)	28480	2100-3066
56	08553-0009	1	BRACKET:POT	28480	08553-0009
57	2200-0165		SCREW:FLAT HD POZI DR 4-40 X 1/4"	00000	OBD
58	08556-00004	1	GUSSET:RIGHT	28480	08556-00004
59	3101-0070	1	SWITCH:SLIDE (S3 RANGE KHZ)	79727	G-126
60	3101-1533	2	SWITCH:SLIDE DP3 POS. MINIAITURE (S1 DBM/DBV)	78488	SS-93
61	08556-00009	1	PLATE:CONNECTOR	28480	08556-00009
62	08556-00002	1	FANEL:FRONT	28480	08556-00002
63			NOT ASSIGNED		
64	3101-1299	1	SWITCH:PUSH BUTTON DPDT (S2 20KHZ MARKER)	71590	PB-1
65			NOT ASSIGNED		
66	5020-839	1	KNOB:PUSH	28480	08556-20013
67	08556-20014	1	KNOB:TURN	28480	08556-20014

See introduction to this section for ordering information

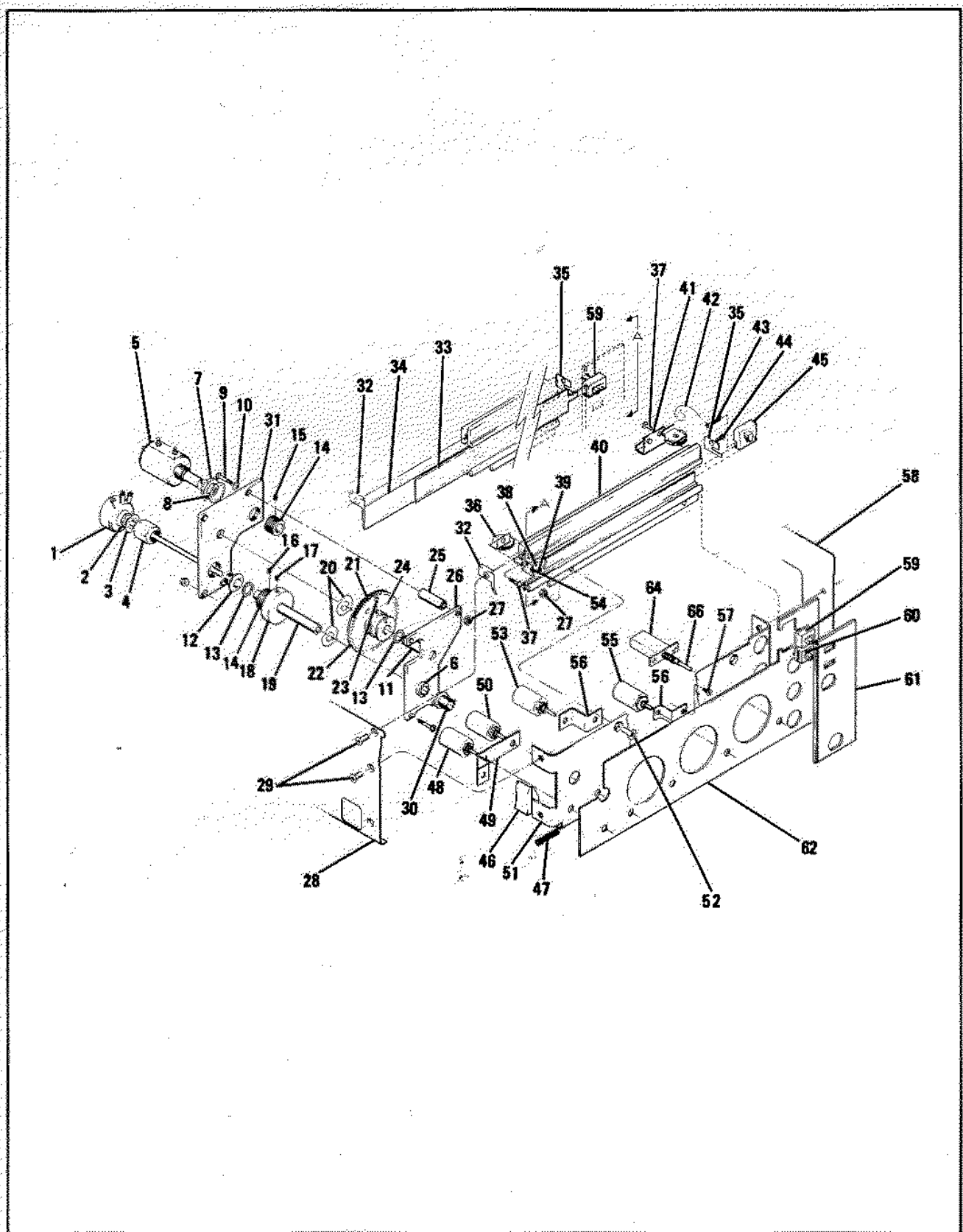

Figure 6-1. Front Panel Parts - Exploded View

SECTION VIII SERVICE

8-1. INTRODUCTION

8-2. This section provides instructions for troubleshooting and repairing the Hewlett-Packard Model 8556A Spectrum Analyzer LF Section.

8-3. Theory of Operation

8-4. Theory of operation appears on the foldout pages opposite the block diagram on Service Sheet 2 and on the pages opposite the schematic diagrams on Service Sheets 3 through 12. The block diagram on Service Sheet 2 is keyed to the remaining service sheets so that the reader may quickly locate the schematic and theory concerning any specific circuit.

8-5. Recommended Test Equipment

8-6. Test equipment and test equipment accessories required to maintain the LF Section are listed in Tables 1-4 and 1-5. Equipment other than that listed may be used if it meets the listed minimum specifications.

8-7. Board level troubleshooting without Extender Cable Assembly HP 11592-60015 is not recommended. Component level troubleshooting and repair without the extender cable, Interconnection Cable Assembly HP 11592-60016, and the Extender Board HP 5060-0256 is not recommended. Selectro to BNC adapters HP 1250-1236 and HP 1250-1237 facilitate testing signal levels and wave-shapes but are not absolutely necessary. (The TRACKING GEN OUT cable - red - can be used as a Selectro Plug to BNC adapter.)

8-8. Troubleshooting

8-9. The troubleshooting procedures in this manual fall into three categories.

8-10. The troubleshooting tree is designed to isolate trouble to the board or assembly level.

8-11. The troubleshooting block diagram is designed to be used as a quick reference by the technician who is familiar with the LF Section and does not wish to go through the troubleshooting- tree. It will also isolate trouble to the board or assembly level.

8-12. Circuit level troubleshooting and analysis is provided on the foldout page opposite each schematic.

After the cause of a trouble has been isolated and corrected, check the troubleshooting information associated with that circuit for any adjustments that may have to be performed.

8-13. GENERAL SERVICE INFORMATION

8-14. Part Location Aids

8-15. The locations of chassis-mounted parts and major assemblies are shown in Figure 8-14. The locations of individual components mounted on printed circuit boards or other assemblies are shown on the appropriate schematic diagram page or on the page opposite it. The part reference designator is the assembly designator plus the part designator. (Example: A10R9 is R9 on the A10 assembly.) For specific component description and ordering information refer to the parts list in Section VI.

8-16. Factory Selected Components

8-17. Some component values are selected at the time of final checkout at the factory (see Table 8-1). Usually these values are not extremely critical; they are selected to provide optimum compatibility with associated components. These components are identified on individual schematics by an asterisk (*). The recommended procedure for replacing a factory-selected part is as follows:

- a. Try the original value, then perform the calibration test specified for the circuit in the performance and adjustment sections of this manual.
- b. If calibration cannot be accomplished, try the typical value shown in the parts list and repeat the test.
- c. If the test results are still not satisfactory, substitute various values within the tolerances specified in Table 8-1 until the desired result is obtained.

8-18. Diagram Notes

8-19. Table 8-3, Schematic Diagram Notes, provides information relative to symbols and measurement units shown in schematic diagrams.

Table 8-1. Factory Selected Components

Component	Location	Range of Values	Basis of Selection
A1R1	Service Sheet 9	1.33K To 1.21k ohms	Sets upper limit of 300 KHz ADJ Select for +15.85 V at test point A (A11XA7 pin 5) with analyzer set as follows: RANGE..0-300 KHz FREQUENCY..300KHz FINE TUNE ...centered 300 kHz ADJ ...full cw
A8A1L3	Service Sheet 7	56.0 to 47.0 μH	of TRACK ADJ. Select for range of 3 MHz ± 140 Hz of 3 MHz oscillator. (Increasing value of A8A1L3 will lower center of tuning range)
A8R7	Service Sheet 7	38.0 to 42.2 ohms	Sets gain of A8Q1 at 300 kHz. Selected so that FLATNESS ADJ A8R9 can adjust flatness within limits.
A8A1R2	Service Sheet 7	2K to 3K	Adj. range of A8A1R1. to select for 115 mVrms (into open ckt.) from J2, TRACKING GEN OUT, with A8A1R1 centered.

8-20. Servicing Aids on Printed Circuit Boards

8-21. The servicing aids include test points, transistor and integrated circuit designations, adjustment call outs and assembly stock numbers.

8-22. Circuit Board Extender

8-23. A 20-pin extender board, HP 5060-0256 is required to extend the circuit boards clear of the chassis. This provides easy access to components and test points. See Figure 8-1 for a typical example of extender board use.

8-24. GENERAL SERVICE HINTS

8-25. Etched Circuits

8-26. The etched circuit boards in the LF Section are of the plated-through type consisting of metallic conductors bonded to both sides of insulating material. The metallic conductors are extended through the component mounting holes by a plating process. Soldering can be done from either side of the board with equally good results. Table 8-2 lists recommendations and precautions pertinent to etched circuit repair work.

a. Avoid unnecessary component substitution; it can result in damage to the circuit board and/or adjacent components.

b. Do not use a high-power soldering iron on etched circuit boards. Excessive heat may lift a conductor or damage the board.

c. Use a suction device (Table 8-2) or wooden toothpick to remove solder from component mounting holes. DO NOT USE A SHARP METAL OBJECT SUCH AS AN AWL OR TWIST DRILL FOR THIS PURPOSE. SHARP OBJECTS MAY DAMAGE THE PLATED-THROUGH CONDUCTOR.

d. After soldering, remove excess flux from the soldered areas and apply a protective coating to prevent contamination and corrosion. See Table 8-2 for recommendation.

8-27. Etched Conductor Repair

8-28. A broken or burned section of conductor can be repaired by bridging the damaged section with a length of tinned copper wire. Allow adequate overlay and remove any varnish from etched conductor before soldering wire into place.

8-29. Component Replacement

8-30. Remove defective component from board.

NOTE

Axial lead components, such as resistors and tubular capacitors, can be replaced without unsoldering. Clip leads near body of defective component, remove component and straighten leads left in board. Wrap leads of replacement component one turn around original leads. Solder wrapped connection, and clip off excess lead.

8-31. If component was unsoldered, remove solder from mounting holes, and position component as original was positioned. DO NOT FORCE LEADS INTO MOUNTING HOLES; sharp lead ends may damage plated-through conductor.

8-32. Transistor Replacement. Transistors are packaged in many physical forms. This sometimes results in confusion as to which lead is the collector, which is the emitter, and which is the base. Figures 8-2 and 8-3 show typical epoxy and metal case transistors and integrated circuits and the means of identifying the leads.

8-33. To replace a transistor, proceed as follows:

a. Do not apply excessive heat; see Table 8-2 for recommended soldering tools.

b. If possible, use long-nose pliers between transistor and hot soldering iron as a heat sink. The

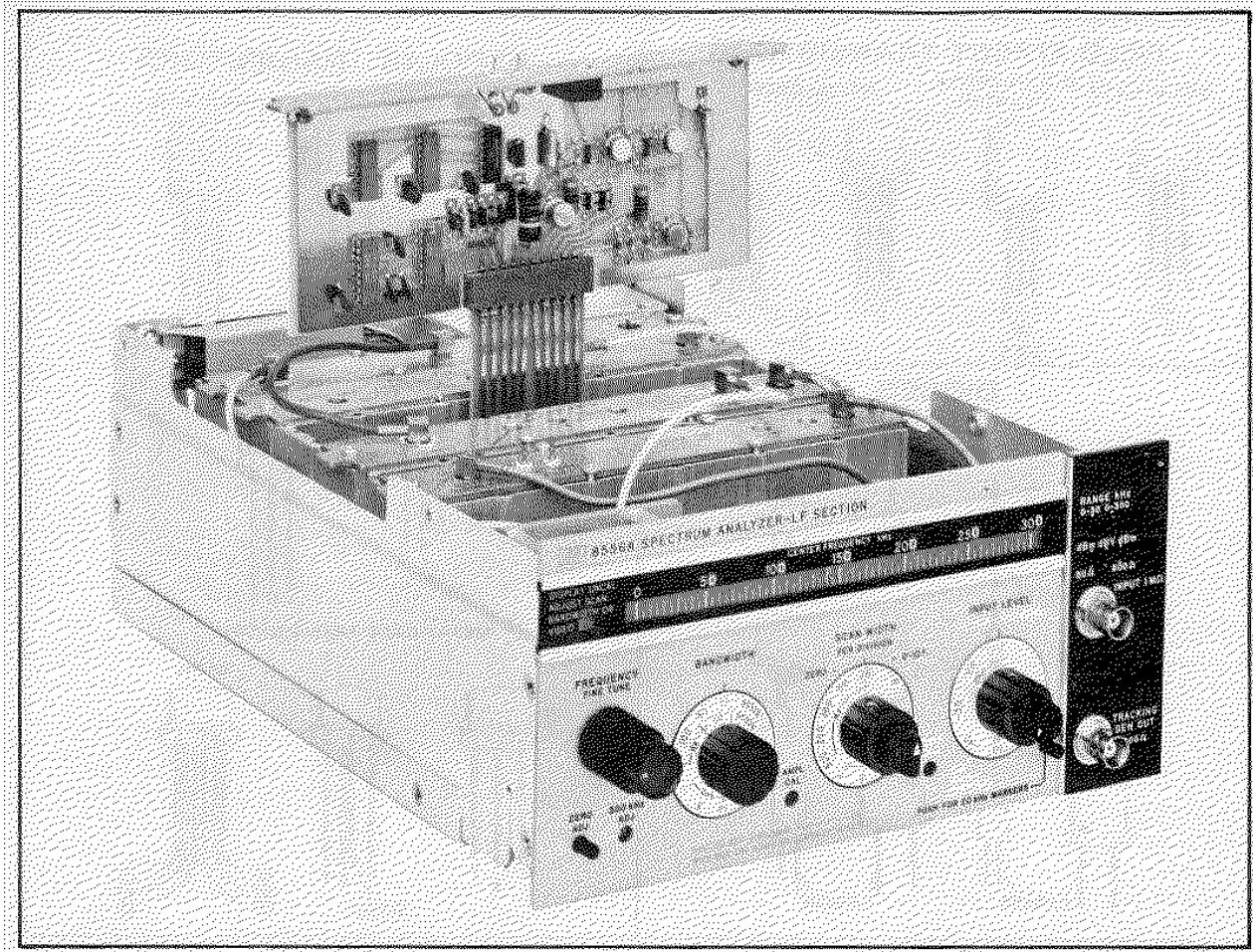

Figure 8-1. 8556A LF Section with Circuit Board Extended

instant solder is melted, use desoldering aid to remove solder from mounting hole.

c. When installing replacement transistor, ensure sufficient lead length to dissipate soldering heat by using about the same length of exposed lead as useful for original transistor.

d. Integrated circuit replacement instructions are the same as those for transistors.

8-34. Some transistors are mounted on heat sinks for good heat dissipation. This requires good thermal contact with mounting surfaces. To assure good thermal contact for a replacement transistor, coat both sides of the insulator with Dow Corning No. 5 silicone compound or equivalent before fastening the transistor to the chassis. Dow Corning No. 5 compound is available in 8 oz. tubes from Hewlett-Packard; order HP Part No. 8500-0059.

8-35. Diode Replacement. Solid state diodes are in many physical forms. This sometimes results in

confusion as to which lead or connection is the cathode (negative) and which lead is the anode (positive), since not all diodes are marked with the standard symbols. Figure 8-2 shows examples of some diode marking methods. If doubt exists as to polarity, an ohmmeter may be used to determine the proper connection. It is necessary to know the polarity of the ohms lead with respect to the common lead for the ohmmeter used. (For the HP Model 410B Vacuum Tube Voltmeter, the ohms lead is negative with respect to the common; for the HP Model 412A DC Vacuum Tube Voltmeter, the ohms lead is positive with respect to the common.) When the ohmmeter indicates the least diode resistance, the cathode of the diode is connected to the ohmmeter lead which is negative with respect to the other lead.

NOTE

Replacement instructions are the same as those listed for transistor replacement.

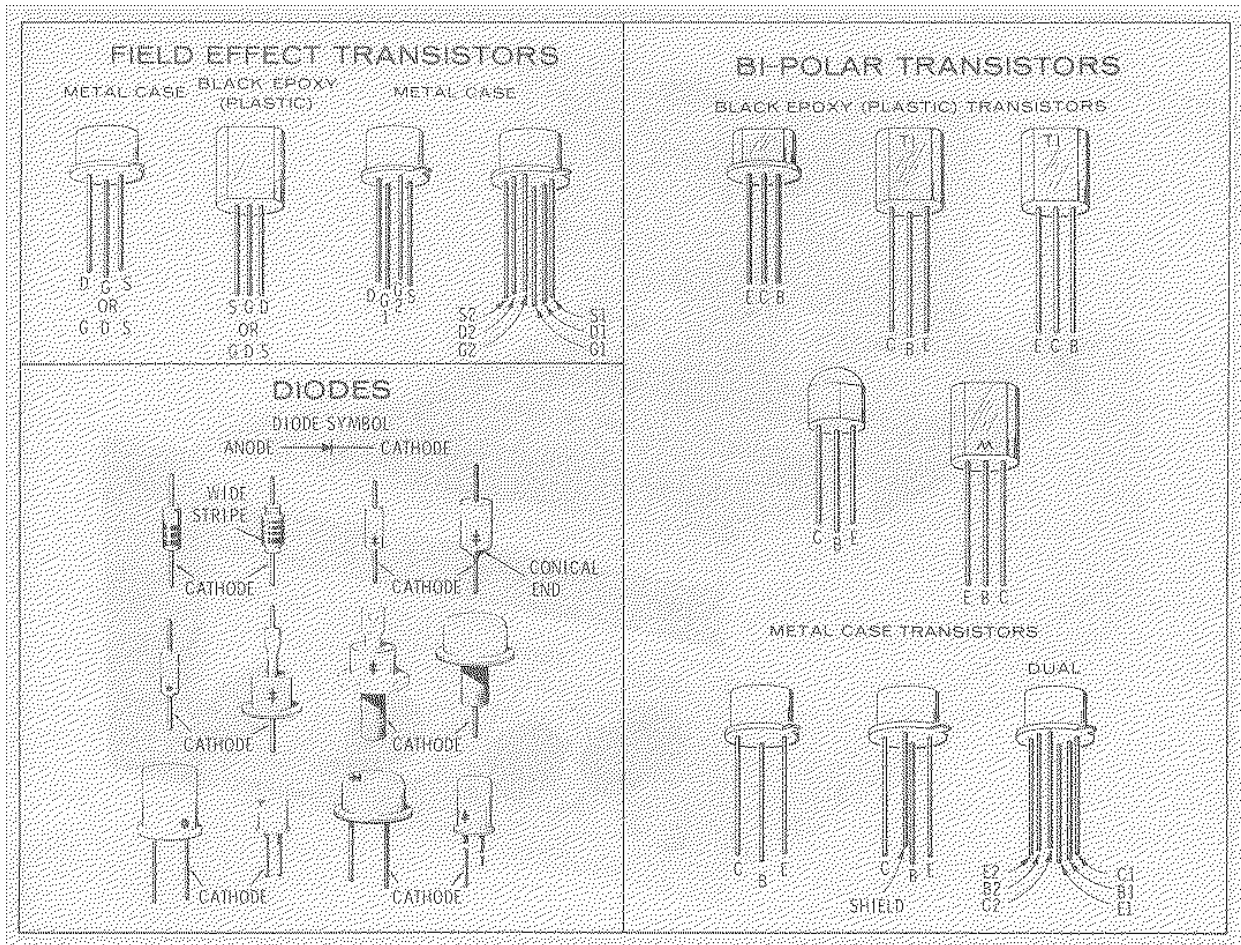

Figure 8-2. Examples of Diode and Transistor Marking Methods

Table 8-2. Etched Circuit Soldering Equipment

ITEM	USE	SPECIFICATION	ITEM RECOMMENDED
Soldering tool	Soldering, unsoldering	Wattage rating: 37-50; Tip Temp: 750-8000	Ungar #766 handle w/*Ungar #1237 heating unit
Soldering Tip	Soldering, unsoldering	*Shape: pointed	*Ungar # PL111
De-soldering Aid	To remove molten solder from connection	Suction device	Soldapullt by Edsyn Co., Arleta, California
Resin (flux) Solvent	Remove excess flux from soldered area before application of protective coating	Must not dissolve etched circuit base board	Freon; Acetone; Lacquer Thinner
Solder	Component replacement Circuit board repair Wiring	Resin (flux) core, high tin content (60/40 tin/lead), 18 gauge (SWG) preferred	
Protective Coating	Contamination, corrosion protection	Good electrical insulation, corrosion prevention properties	Silicone Resin such as GE DRI-FILM**88

*For working on 8556A Boards: for general purpose work, use Ungar No. 4037 Heating Unit (47/r-56V2W) tip temperature of 850-900 degrees) and Ungar No. PL113 1/8" chisel tip

**General Electric Co., Silicone Products Dept, Waterford, New York, U.S.A.

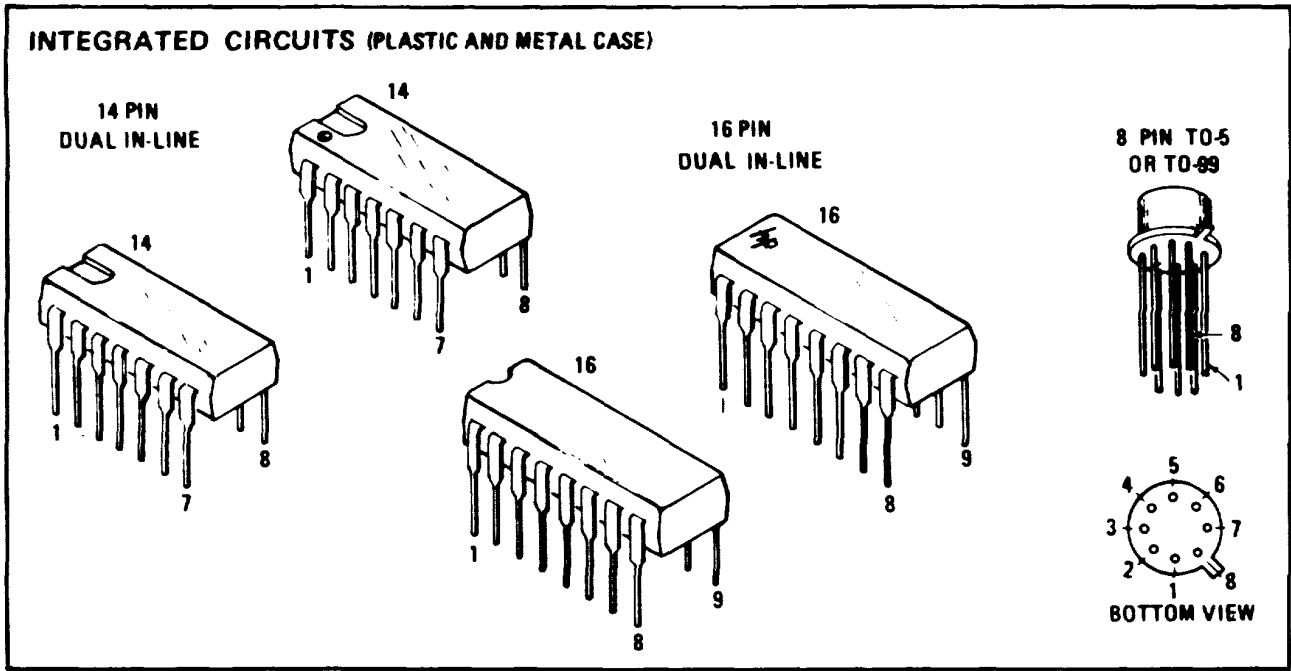

Figure 8-3. Integrated Circuit Packaging

8-36. LOGIC CIRCUITS AND SYMBOLS

8-37. The following paragraphs and illustrations provide basic information about logic circuits and symbols. While a complete treatment of the subject is not within the scope of this manual, it is believed that this material will help the technician experienced with analog devices, who has had little or no experience with digital circuits.

8-38. The circuits discussed are digital in nature; their outputs are always in one of two possible states, a "1" or "0". These two states are also referred to as being either high (H) or low (L). The

high and low states are relative; low must be less positive (more negative) than high, both states may be positive or negative, or high may be positive and low negative. In positive logic the more positive (H) state is a logical "1" and the more negative (L) state is a logical "0". In negative logic the more negative (L) state is a logical "1" and the more positive (H) state is a logical "0".

8-39. Two of the basic "building blocks" of logic circuits are the AND and OR gates. The symbols and truth tables for basic AND and OR gates are shown in Figure 8-4.

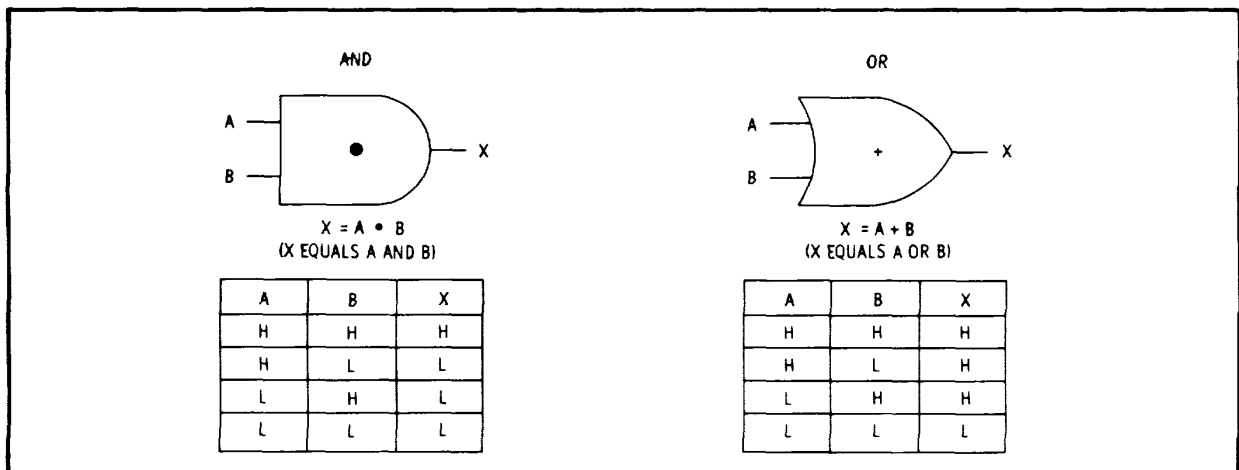

Figure 8-4. Basic AND and OR Gates

8-40. Basic AND Gate (Positive Logic)

8-41. The basic AND gate is a circuit which produces an output "1" when, and only when, a "1" is applied to all inputs. As shown in Figure 8-4, terminal X will be high only when terminals A and B are both high. The dot (•) shown in the AND gate is the logic term for AND. The term for a simple two input AND gate is $X = A \cdot B$ (X equals A and B). AND gates may be designed to have as many inputs as required to fill a specific requirement.

8-42. Basic OR Gate (Positive Logic)

8-43. The basic OR gate is a circuit which produces a "1" output when any one or all of the inputs are in the "1" state. As shown in Figure 8-4, terminal X will be high when either terminal A or terminal B, or both are high. The + shown in the OR gate symbol is the logic term for OR. The term for a simple two input OR gate is $X = A + B$ (X equals A or B). OR gates may be designed to have as many inputs as required for specific needs.

8-44. The symbols for AND and OR gates differ in that AND gates symbols have a flat input side and a rounded output side while OR gate symbols have a concave input side and a pointed output side.

8-45. Truth Tables

8-46. Truth tables provide a means of presenting, in tabular form, the Output State of logic devices for any set of inputs. Truth tables contain one column for each of the inputs and a column for the output. In basic truth tables the column notations are usually H or L (for high and low) or, for binary notation, "1" or "0".

8-47. Logic Inversion

8-48. Adding inversion to AND and OR gates changes their characteristics. Inversion is usually accomplished by adding an inverter stage (common emitter) in front of an input or after an output. A circle is added to the input or output leads of the symbol to indicate the portion of the circuit in which the inversion takes place. The simplest of these devices are AND and OR gates in which the output is inverted. These gates are called NAND (for Not AND) and NOR (for Not OR). Basic NAND and NOR gates are shown in Figure 8-5. When all inputs and outputs of an AND gate are inverted, it functions as an OR gate. When all inputs and outputs of an OR gate are inverted, it functions as an AND gate. Figure 8-6 provides information relative to various gate inversion functions.

8-49. BINARY CIRCUITS AND SYMBOLS

8-50. Many types of flip-flops are used in binary circuits. Each half of a flip-flop is in one of two states at any given time. The outputs are complementary; when one stage is on, the other is off. The text identifies these outputs as Q and \bar{Q} . The outputs are termed 1 and 0, high and low, or true and false, by the same rules that apply to AND and OR gates.

8-51. Reset-Set (RS) Flip-Flop

8-52. Figure 8-7 shows an RS flip-flop. The RS flip-flop has two inputs, S for set and R for reset (sometimes labeled S for set and C for clear). Assume that initially Q is high (Q2 off) and \bar{Q} is low (Q1 on). In this state the flip-flop is set and a

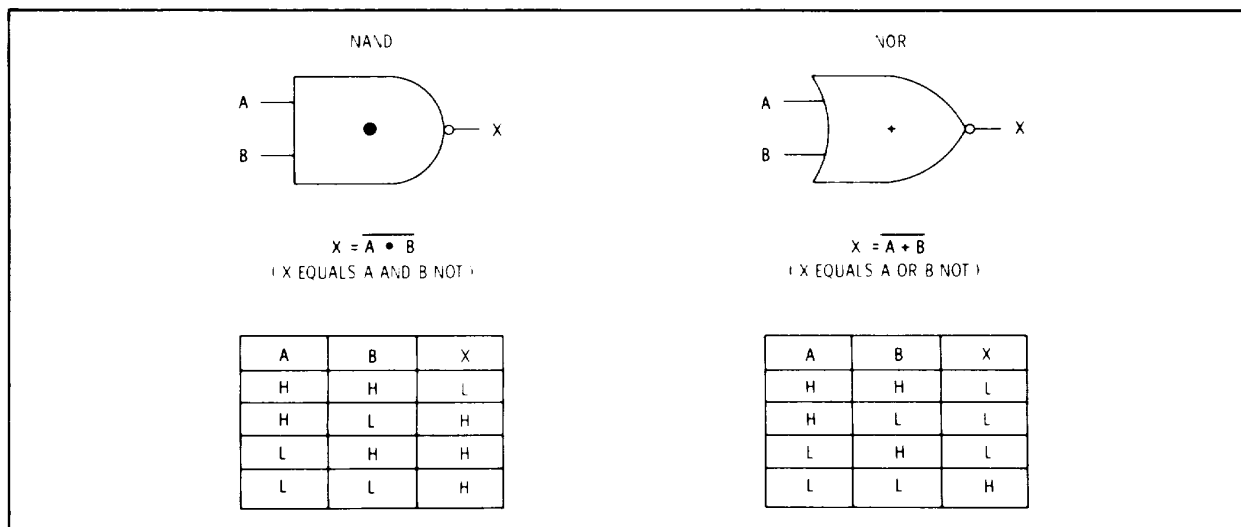

Figure 8-5. Basic NAND and NOR Gates

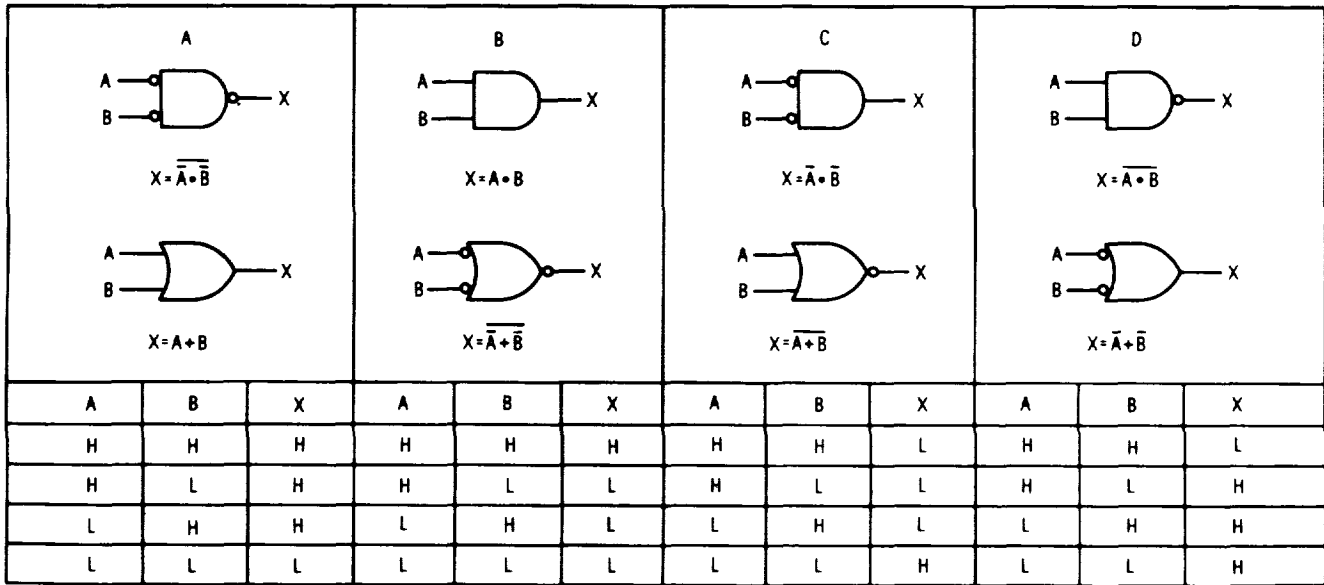

Figure 8-6. Logic Comparison Diagrams

positive pulse at the set input will not affect the circuit. When a positive pulse is applied to the reset input it is coupled through C4 and CR2 to the base of Q2. Q2 begins to conduct and the negative going collector voltage is coupled through C3 to the base

of Q1 to cut off Q1. The process is regenerative; Q1 is quickly cut off and Q2 saturates. The flip-flop will remain in the reset state until a positive set pulse is applied through C2 and CR1 to the base of Q1.

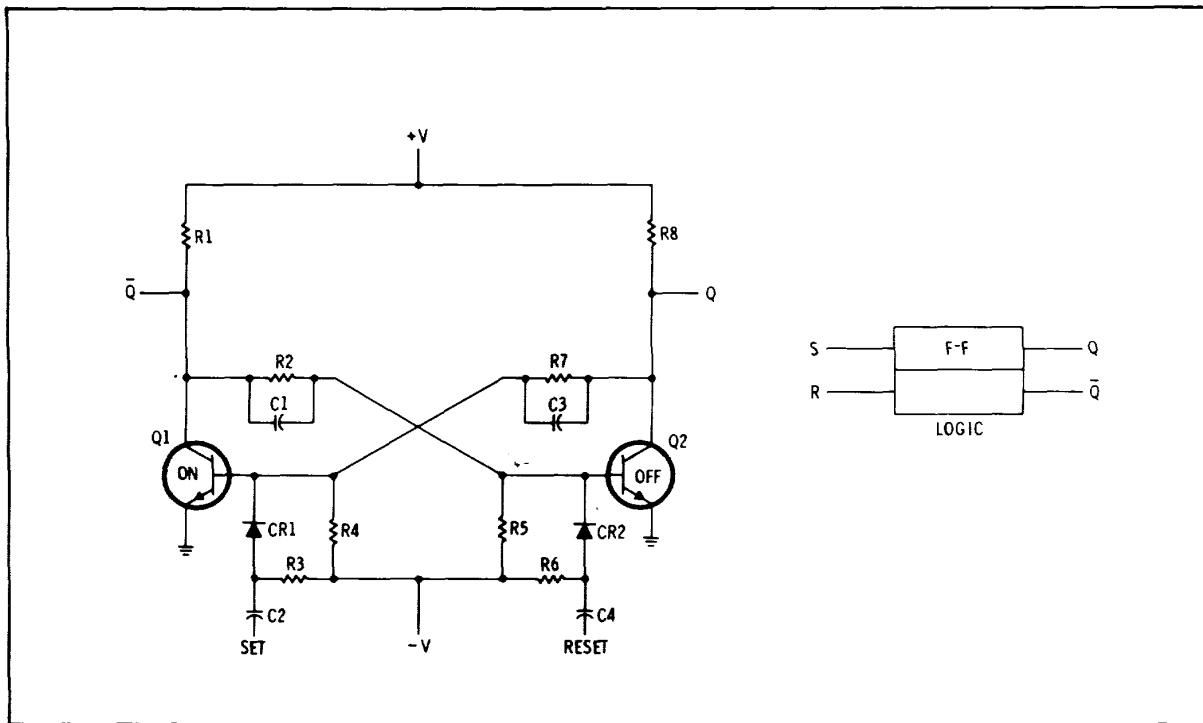

Figure 8-7. RS Flip-Flop

8-53. The RST Flip-Flop

8-54. Figure 8-8 shows an RST flip-flop. It can be set and reset like the RS flip-flop and, in addition, it can be toggled back and forth between its two stable states. A positive pulse (or high) at the S input will set Q high; a high at the R input will set Q low. The circle on the symbol means that the trigger input responds to negative-going triggers. The flip-flop will switch between its two stable states on each input trigger. That is, if Q is high, the next trigger will cause Q to go low.

8-55. Clocked JK Flip-Flop

8-56. The clocked JK flip-flop may be assembled from an RS flip-flop, an inverter, and two AND gates. The flip-flop is shown in Figure 8-9 along with its truth table. It has three inputs and two outputs. The clock input is fed by negative (or low) triggers as indicated by the circle on

the symbol. Flip-flop response is determined by the values of the J and K inputs at the instant that the trigger pulse arrives at the clock input:

- a. When J and K are low, the flip-flop will remain in whatever state it is in.
- b. When K is high and J is low, the trigger will cause Q to go low (unless it is already low).
- c. When J is high and K is low, the trigger will cause Q to go high (unless it is already high).
- d. When J and K are both high, the flip-flop will toggle between its two stable states. That is, if Q is high, the next trigger will set Q low.

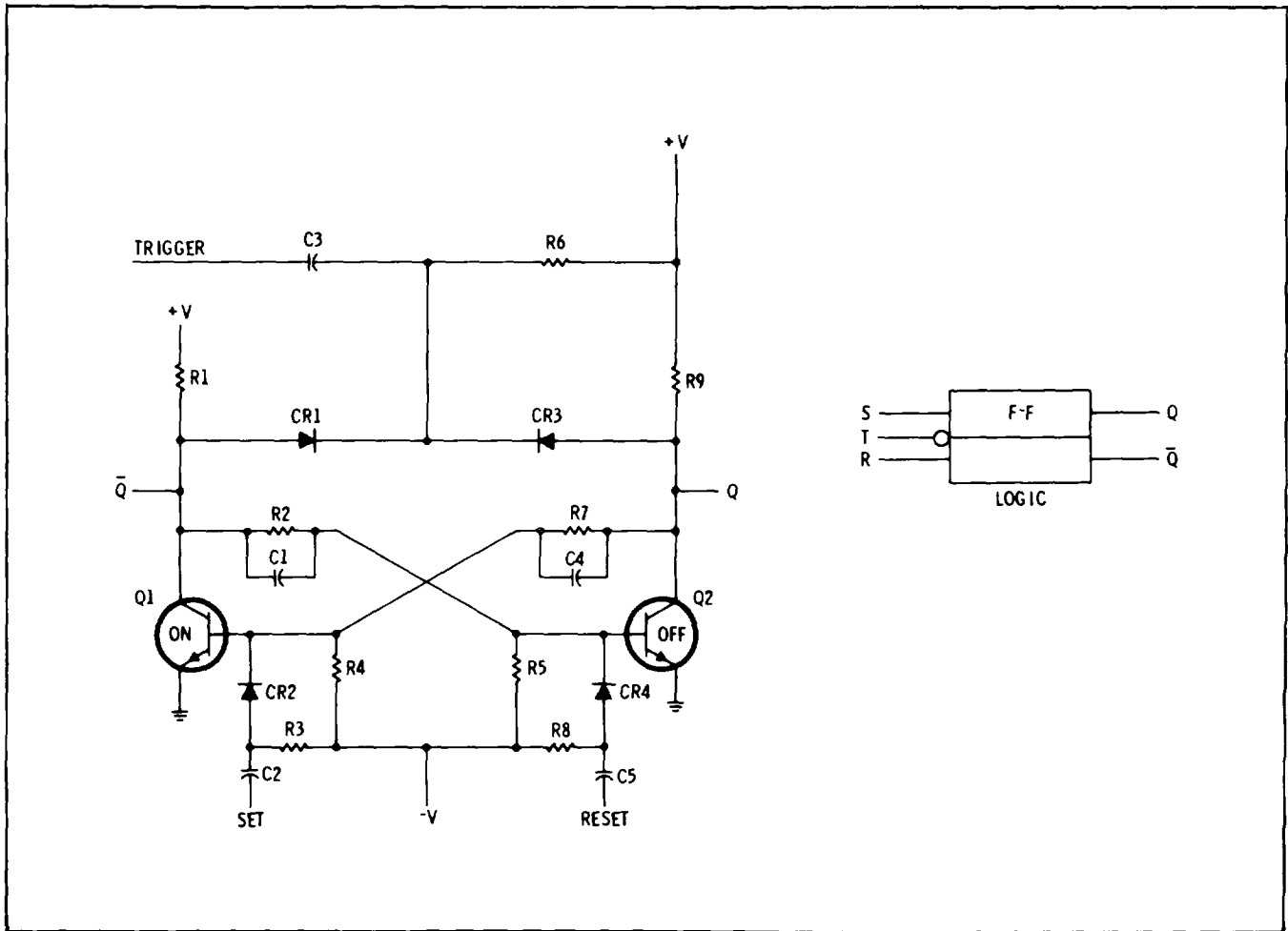

Figure 8-8. RST Flip-Flop

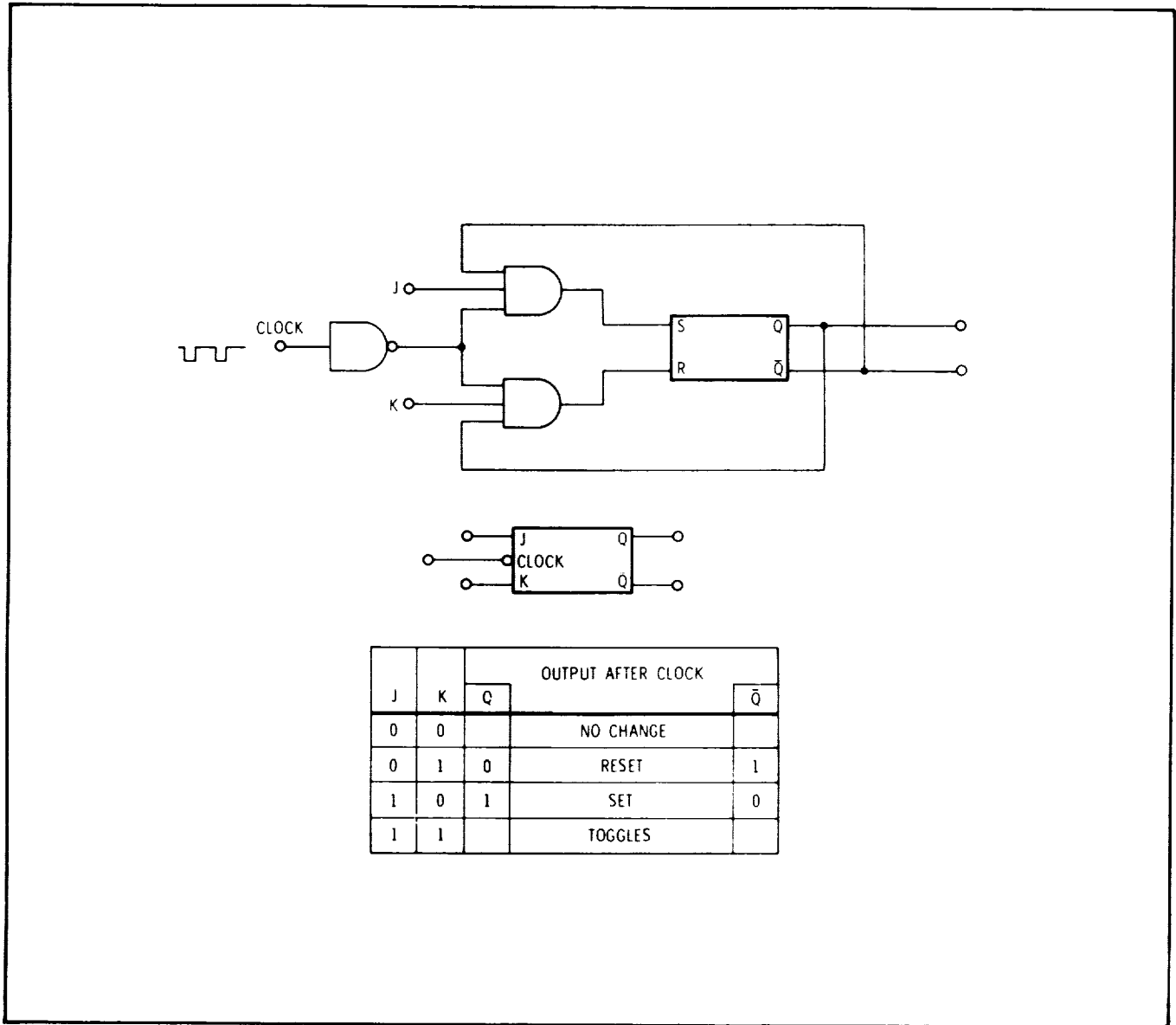

Figure 8-9. The Clocked JK Flip-Flop

8-57. JK Master/Slave Flip-Flop

8-58. The JK master/slave flip-flop has the same truth table as the JK flip-flop. However, the sequence of operation is not the same. The regular JK flip-flop responds only to the negative portion of the input clock:

a. While the trigger (or clock) pulse is high, the J and K inputs are isolated from the flip-flop.

b. When the trigger goes low, the information at the J and K inputs is fed into the flip-flop to control its outputs.

c. When the trigger again goes high, the J and K inputs are isolated from the flip-flop.

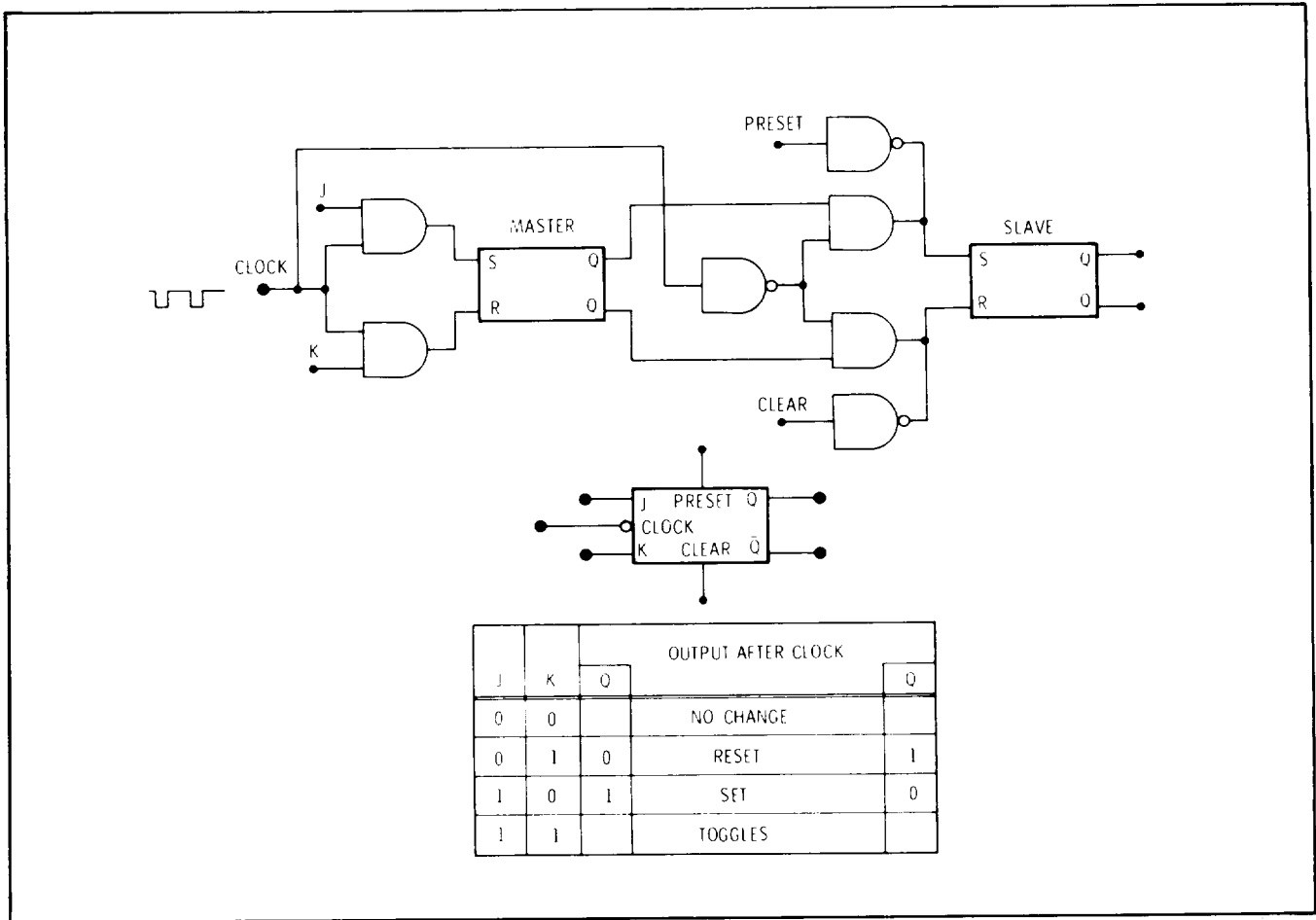

Figure 8-10. JK Master/Slave Flip-Flop

8-59. Figure 8-10 shows one way to assemble a JK master/slave flip-flop. This flip-flop responds to both the positive and the negative portions of the input clock:

- a. While the trigger (or clock) pulse is high, the master flip-flop is isolated from the slave flip-flop and J and K information is fed into the master.
- b. When the trigger goes low, the J and K inputs to the master are disabled. At the same time the information in the master flip-flop is fed into the slave to control the slave's outputs.
- c. When the trigger again goes high, the master is isolated from the slave and J and K information is again fed into the master flip-flop.

8-60. Preset and Clear

8-61. Note in Figure 8-10 that the slave flip-flop has preset and clear inputs connected to it through inverters. Whenever a low is applied to the preset

inverter, the Q output will go high. And whenever a low is applied to the clear inverter, the Q output will go low. These inputs are used in counters and other logic circuits to set flip-flops to a known state, regardless of their other inputs.

8-62. OPERATIONAL AMPLIFIERS

8-63. Circuits and Symbols

8-64. Operational amplifiers are widely used as summing amplifiers, offset amplifiers, buffers and level detectors in regulated power supplies. The particular function is determined by external circuit connections.

8-65. Figure 8-11 shows a typical operational amplifier. Circuit A is a non-inverting buffer amplifier with a gain of 1. Circuit B is a non-inverting amplifier with gain determined by the resistance of R1 and R2. Circuit C is an inverting amplifier with gain determined by R2 and R1. Circuit D shows typical circuit connections and parameters. It is assumed that the amplifier has high gain, low output impedance and high input impedance.

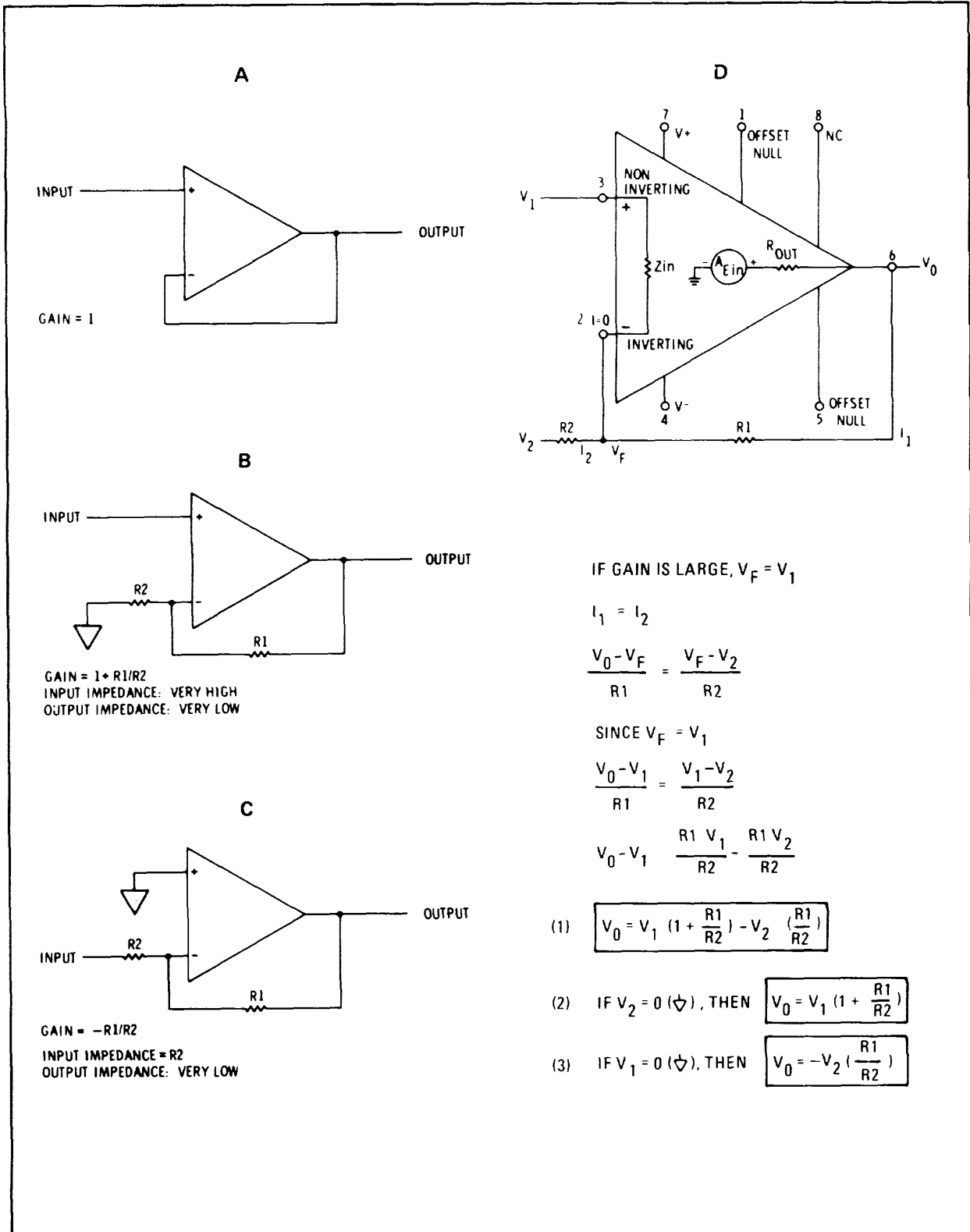

Figure 8-11. Operational Amplifier Equivalent Circuit

8-66. Troubleshooting

8-67. An operational amplifier can be characterized as an ideal voltage amplifier having low output impedance, high input impedance, and very high gain. Also the output voltage is proportional to the difference in the voltages applied to the two input terminals. In use, the amplifier drives the input voltage difference close to zero.

8-68. When troubleshooting an operational amplifier, measure the voltages at the two inputs with no signal applied; the difference between these voltages should be less than 10 mV. A difference voltage much greater than 10 mV indicates trouble in the amplifier or its external circuitry. Usually this difference will be several volts and one of the inputs will be very close to an applied circuit operating voltage (for example, +20V, -12V).

8-69. Next, check the amplifier's output voltage. It will probably also be close to one of the applied circuit potentials: ground, +20V, -12V, etc. Check to see that the output conforms to the inputs. For example, if the inverting input is positive, the output should be negative; if the non-inverting input is positive, the output should be positive. If the output conforms to the inputs, check the amplifier's external circuitry. If the amplifier's output does not conform to its inputs, it is probably defective - replace it.

8-70. DIAL CALIBRATION PROCEDURE

8-71. To restring the frequency dial, follow the procedure outlined in Figure 8-12. After the dial is restring, or after the frequency tuning pot R3 is replaced, perform the following adjustments:



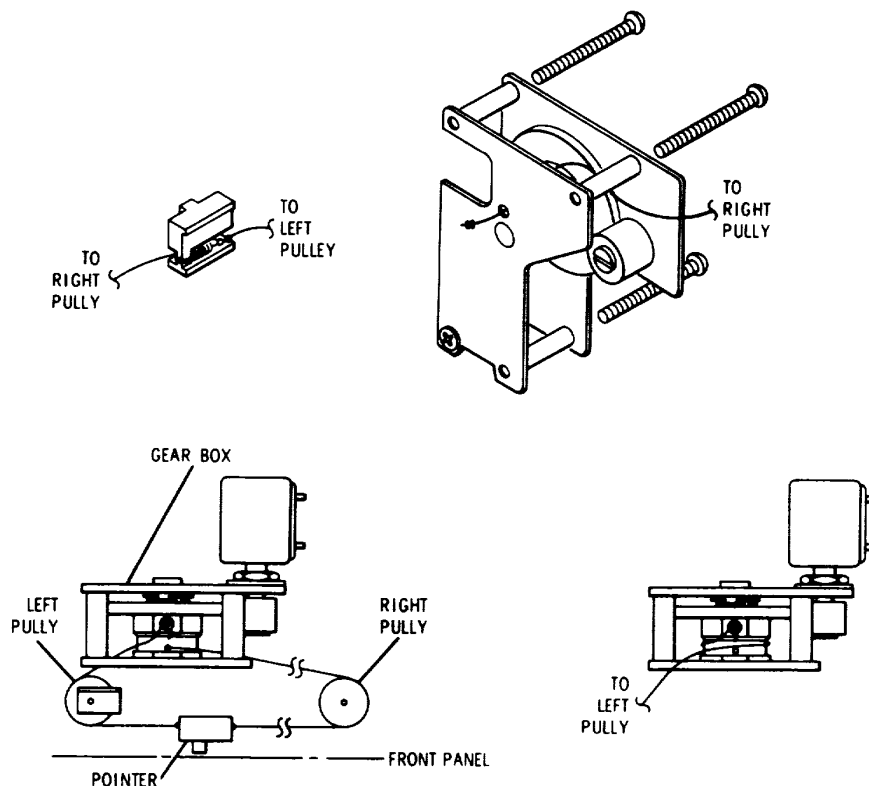













- a. Switch RANGE from 0-30 kHz to 0-300 kHz. The final zeros on the CENTER FREQUENCY dial should all be completely visible.
- b. Turn FREQUENCY full counter-clockwise. The dial pointer should indicate $3/4$ to $1-1/4$ small divisions to the left of 0 kHz.
- c. Turn FREQUENCY full clockwise. The dial pointer should indicate at least $3/4$ of a small division to the right of 300 kHz.
- d. If necessary, loosen the setscrews on the gear shaft of the FREQUENCY pot and re-position the gear slightly by turning the FREQUENCY knob while the pot is at either stop. Then retighten the setscrews and repeat steps b and c.
- e. Perform the frequency calibration adjustments specified in Section V.



1. Remove top cover.
 - a. Tune to low end of scale.
 - b. Remove front panel assembly from side panels.
 - c. Remove scale assembly.
 - d. Remove tuning knobs.
 - e. Remove 2 screws which hold gearbox to panel assembly.
 - f. Remove left pulley at left end of pointer slot.
 - g. Replace gearbox screws.
 - h. Turn shaft fully cw.
2. To replace string on right side of pointer:
 - a. Remove pointer from slot, detach old string.
 - b. Access to fixed end of string is through the hole in the front gearbox plate. Line up dial drum with this hole so that old string may be withdrawn.
 - c. Pass a new piece of dial string (about 15") through the hole and double knot the fixed end. Clip off excess string and draw the knot into the hole.
 - d. Reset the tuning shaft fully ccw.
 - e. Pass the free end of the string into the right end of the pointer slot. Tie it to the pointer spring where it is attached to the pointer.
 - f. Replace pointer in slot.
 - i. Loosen fixing screw at opposite end of string and adjust string tension so that pointer is stretched 3/16" when string is on pulleys.
 - j. Reassemble, using reverse procedure in 1.
3. To replace string on left side of pointer:
 - a. Remove pointer from slot and remove old string.
 - b. Tie approximately 12" of dial string (use double knot) to the pointer spring and replace pointer in slot.
 - c. Replace gearbox screws.
 - d. Turn shaft fully cw.
 - e. Place dial string on pulleys.
 - f. Wrap string around dial drum, and tie under screw-head, while maintaining about 3/16" stretch on pointer spring.
 - g. Reassemble, using reverse of procedure in 1.
4. Check calibration; adjust by moving the 29 tooth gear on the tuning pot shaft. Perform dial calibration procedure.

Figure 8-12. Dial Restringing Procedure

Table 8-3. Schematic Diagram Notes

SCHEMATIC DIAGRAM NOTES		
	Resistance is in ohms, inductance is in microhenries, capacitance is in microfarads unless otherwise noted. P/O = part of. *Asterisk denotes a factory-selected value. Value shown is typical. Capacitors may be omitted or resistors jumpered.	
	Screwdriver adjustment.	
	Encloses front panel designations.	
	Circuit assembly borderline.	
	Other assembly borderline.	
	Heavy line with arrows indicates path and direction of main signal.	
	Heavy dashed line with arrows indicates path and direction of main feedback.	
	Wiper moves toward CW with clockwise rotation of control as viewed from shaft or knob.	
	Numbers in stars on circuit assemblies show locations of test points.	
	Encloses wire color code. Code used (MIL-STD-681) is the same as the resistor color code. First number identifies the base color, second number the wider stripe, and the third number identifies the narrower stripe; e.g. 947 denotes white base, yellow wide stripe, violet narrow stripe.	
	Arrow indicates direction of contact movement when relay is energized.	
	Chassis ground.	
	Isolated ground.	
	Indicates non-shorting switch contact.	
	Indicates shorting switch contact.	
	Indicates voltage isolated from chassis ground	
VI	Indicates voltage-isolated-filtered.	
VIF		

Model 8556A

OVERALL TROUBLESHOOTING TREE

INTRODUCTION

The overall troubleshooting tree can be used to quickly isolate trouble to the circuit board, or assembly, level. To implement repair, turn to the indicated service sheet and follow the troubleshooting procedure.

After repairing a circuit board, perform the adjustment procedures, if any, specified in the troubleshooting procedure.

TROUBLESHOOTING

Equipment:

- AC VoltmeterHP 400EL
- Oscilloscope HP 180A/1801A/1820B
- X10 Oscilloscope ProbeHP 10004A
- Digital VoltmeterHP 3480B/3484A, Option 042
- Cable AssyHP 1102A
- Test OscillatorHP 651B
- BNC Cable Assy (2) HP 10503A
- Adapter HP 1250-1236
- Adapter HP1250-1237
- 50 Ohm Feed Thru TerminationHP 11048B
- Extender Cable AssyHP 11592-60015
- Interconnection Cable AssyHP 11592-60016

Extender Cable Installation

Remove the LF Section and IF Section from the Display Section; install the Extender Cable Assembly in the Display Section and connect the appropriate plugs to the LF and IF Sections. Separate the LF and IF Sections and connect the Interconnection Cable Assembly. (See the step-by-step procedure on Service Sheet 1.)

Measurement Procedure

Use the 8552A/B-8556A Trouble Isolation Troubleshooting Tree to isolate trouble to the 8556A. This tree will also branch to the Frequency Troubleshooting Table or to the Amplitude or Tracking Generator Troubleshooting Trees. The latter will branch to a specific Service Sheet.

Set the analyzer controls as specified on the troubleshooting tree, and apply any specified signals using the Test Oscillator, BNC Cable Assembly, and Adapters. Check the dc voltages with the Digital Voltmeter; check the peak-to-peak voltages with the Oscilloscope, and check the rms voltages with the AC Voltmeter. The AC Voltmeter is also used, with the 50 Ohm Feed Thru Termination, to check the power (dBm) readings.

Note

The quickest way to isolate trouble to the 8556A is to substitute a known-good tuning section (such as an 8553B) for the 8556A. If the trouble persists the malfunction is located in the IF Section or the Display Section.

TROUBLE-SHOOTING TREE

8552A/B - 8556A TROUBLE ISOLATION TROUBLESHOOTING TREE

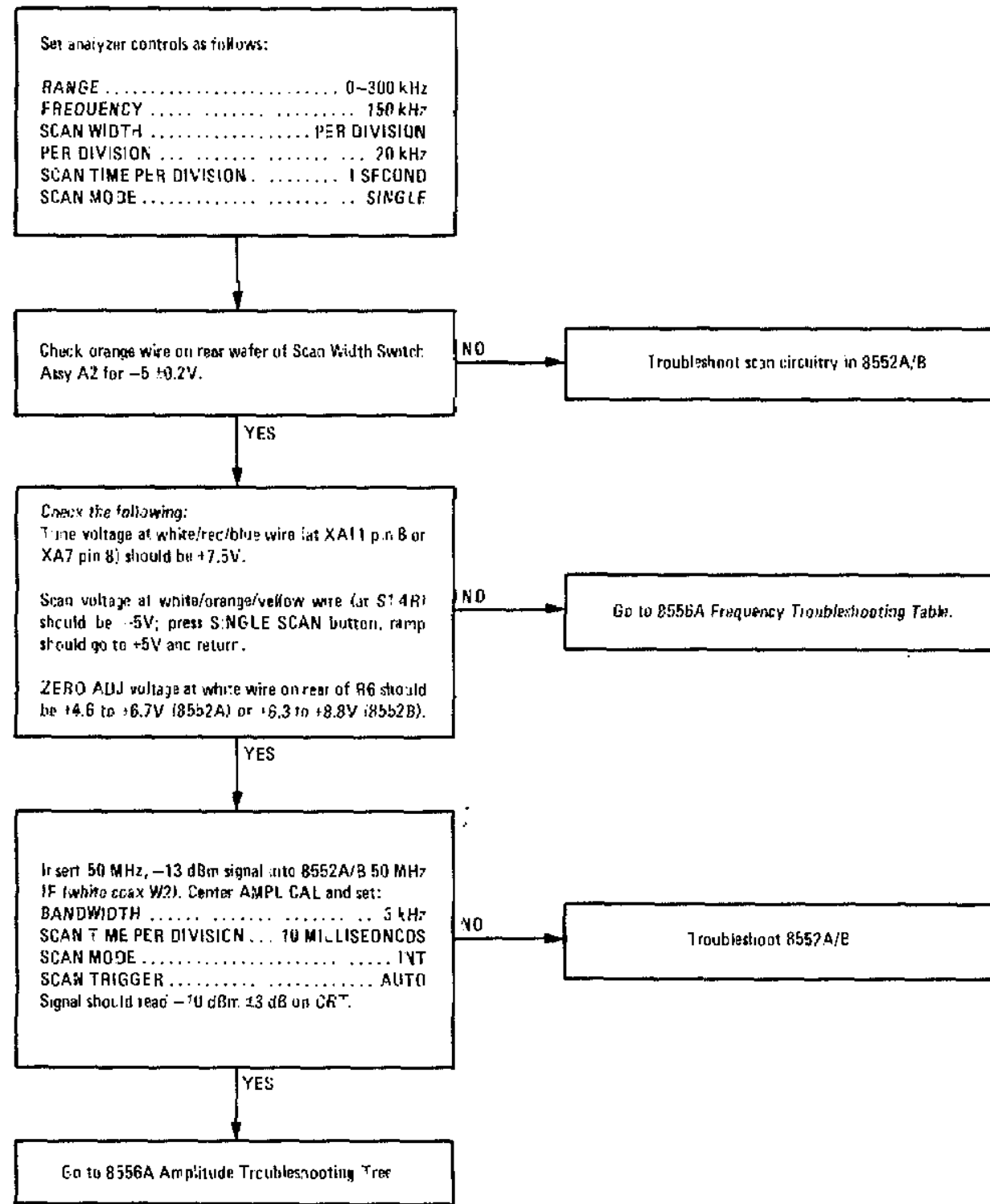

TRACKING GENERATOR TROUBLESHOOTING TREE (no tracking generator output)

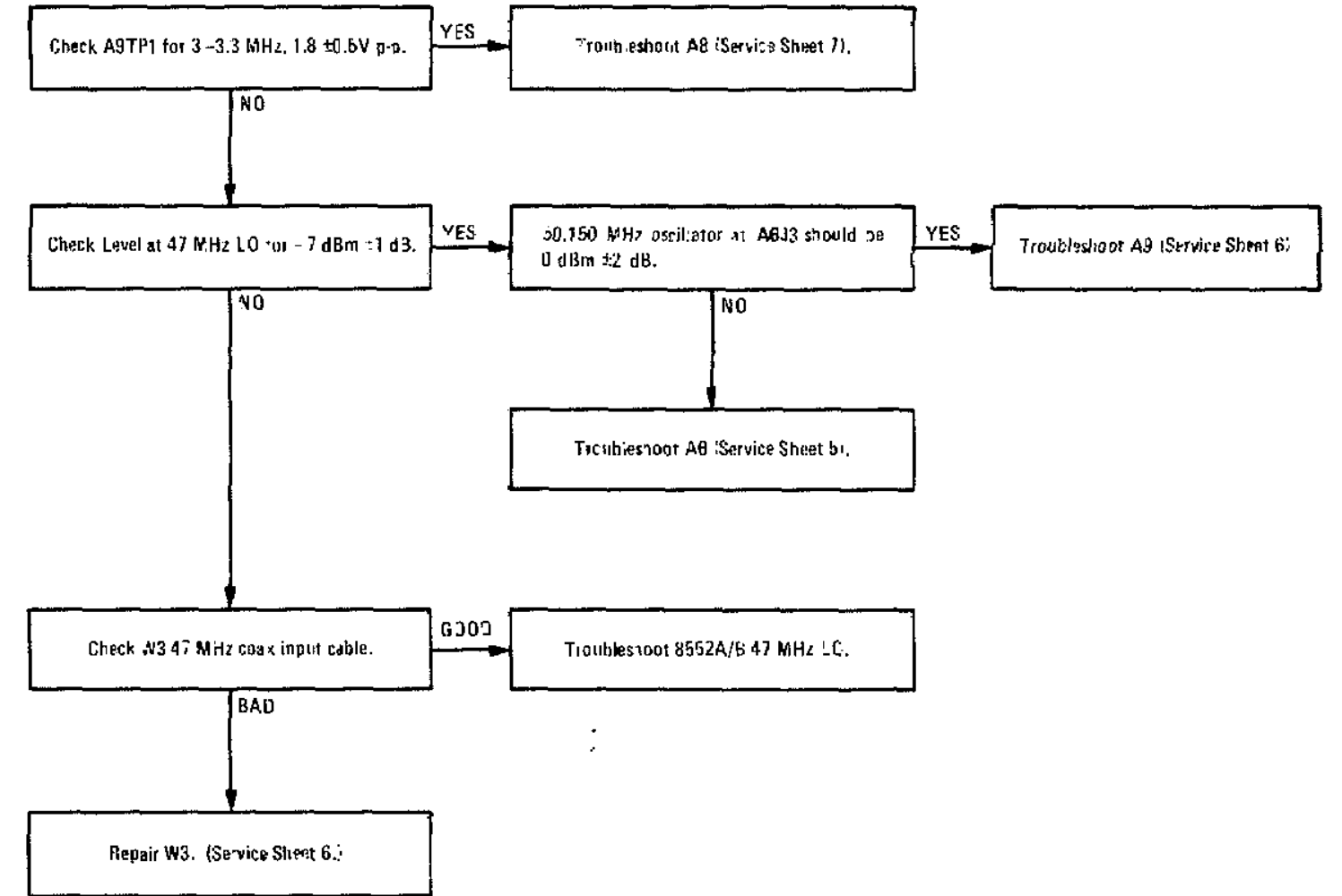
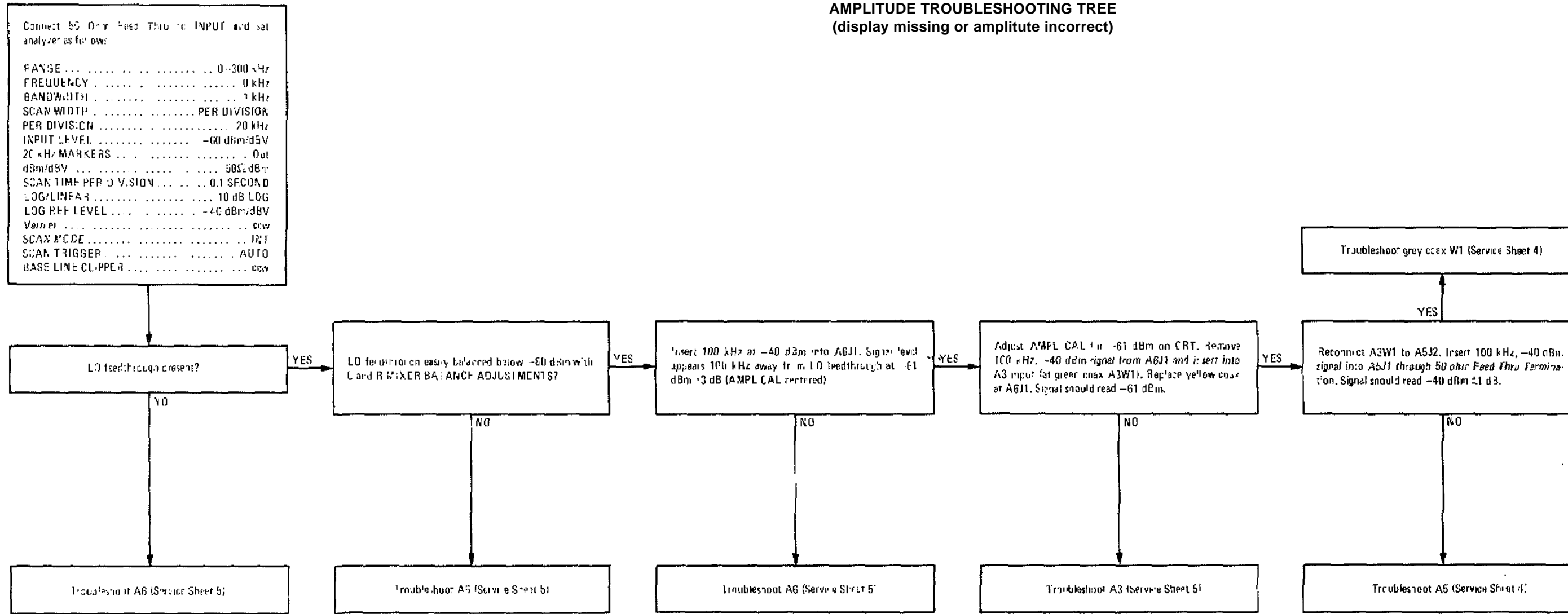

Figure 8-13. Overall Troubleshooting Tree (1 of 2)

**AMPLITUDE TROUBLESHOOTING TREE
(display missing or amplitude incorrect)**



Service

FREQUENCY TROUBLESHOOTING TABLE

Model 8556A

FAULT	TEST
No Markers	a. Check Tracking Generator output at front panel: 3V rms minimum (TRACKING GEN LEVEL full clockwise).
Inaccurate Frequency Indication	b. Check -150 circuitry at XA7 Pin 2 or XA6 Pin 8: 20 kHz comb approximately 130 mV p-p. c. Check coupling into mixer at A6C7: 130 mV p-p.
Inaccurate Frequency Indication	a. Check ZERO ADJ voltages at white wire on rear of R6 (ZERO ADJ). Approximate range: +4.6 to +6.7V (8552A) or +6.3 to +8.8 V (8552B). b. Check 300 kHz voltage at white/orange wire on 300 kHz ADJ R5. Approximate range: 14.8 to 16V. c. Check TUNE voltage to IF plug-in at XA7 Pin 8 or XA11 Pin 8: adjustable from 0-15V approximate. d. Check TUNE voltage at white/red/violet wire on back of rear wafer of SCAN WIDTH switch S2 (or XA7 Pin 9): 0 to 15V approximate.
Inaccurate Scan Width	a. Measure scan voltage at white/orange/yellow wire connected to second wafer from rear of SCAN WIDTH switch S1. The level should be about 10V p-p in 20 kHz/DIV and diminish proportionally with decreasing scan width. b. Check 8552A/B Scan Accuracy.
Noisy or Unstable Sweep	a. Check integrated circuits on A7 FREQUENCY control assembly. b. In 8552A/B check frequency control and 47 MHz VTO.

TROUBLESHOOTING TREE AND INTERNAL VIEWS

Figure 8-13. Overall Troubleshooting Tree (2 of 2)

Table 8-4. Assembly and Component Locations

Component	Service Sheet	Photo
A1	Bandwidth Switch	9, 10, 11
A2	Scan Width Switch	9, 10
A3	Input Level Switch	4, 5, 7, 11
A4	(Reserved for Balanced Input)	(3)
A5	Pre-Attenuator and Preamplifier	4
A6	Frequency Converter	5
A7	Frequency Control and Marker Generator	8,9
A8	Tracking Generator Output	7
A9	Tracking Generator Frequency Converter	6
A10	Power Supply	12
A11	Master Board	4, 5, 6, 7, 8, 9, 12
Component	Service Sheet	Photo/Location
C1	DISPLAY UNCAL Lamp	4
DS1	INPUT 1 MQ	12
J1	TRACKING GEN OUT 600 2	4
J2	Not Assigned	7
P1	LF Section/Display Section	12
P2	TRACK ADJ	4, 6, 9, 10, 11, 12
P3	Not Assigned	7
R1	FREQUENCY	9
R2	FINE TUNE	9
R3	300 kHz ADJ	9
R4	ZERO ADJ	9
R5	AMPL CAL	11
R6	dBm/dBV	4
R7	20 kHz MARKERS	8
S1	RANGE kHz	9
S2	Signal Input - Gray	4
S3	50 MHz Out - White	5
W1	47 MHz LO Input - White	6
W2	Tracking Gen Out - Red	7
W3	dBm/dBV - Orange	4
XA11		4, 7, 8, 9, 12

INTERNAL VIEWS

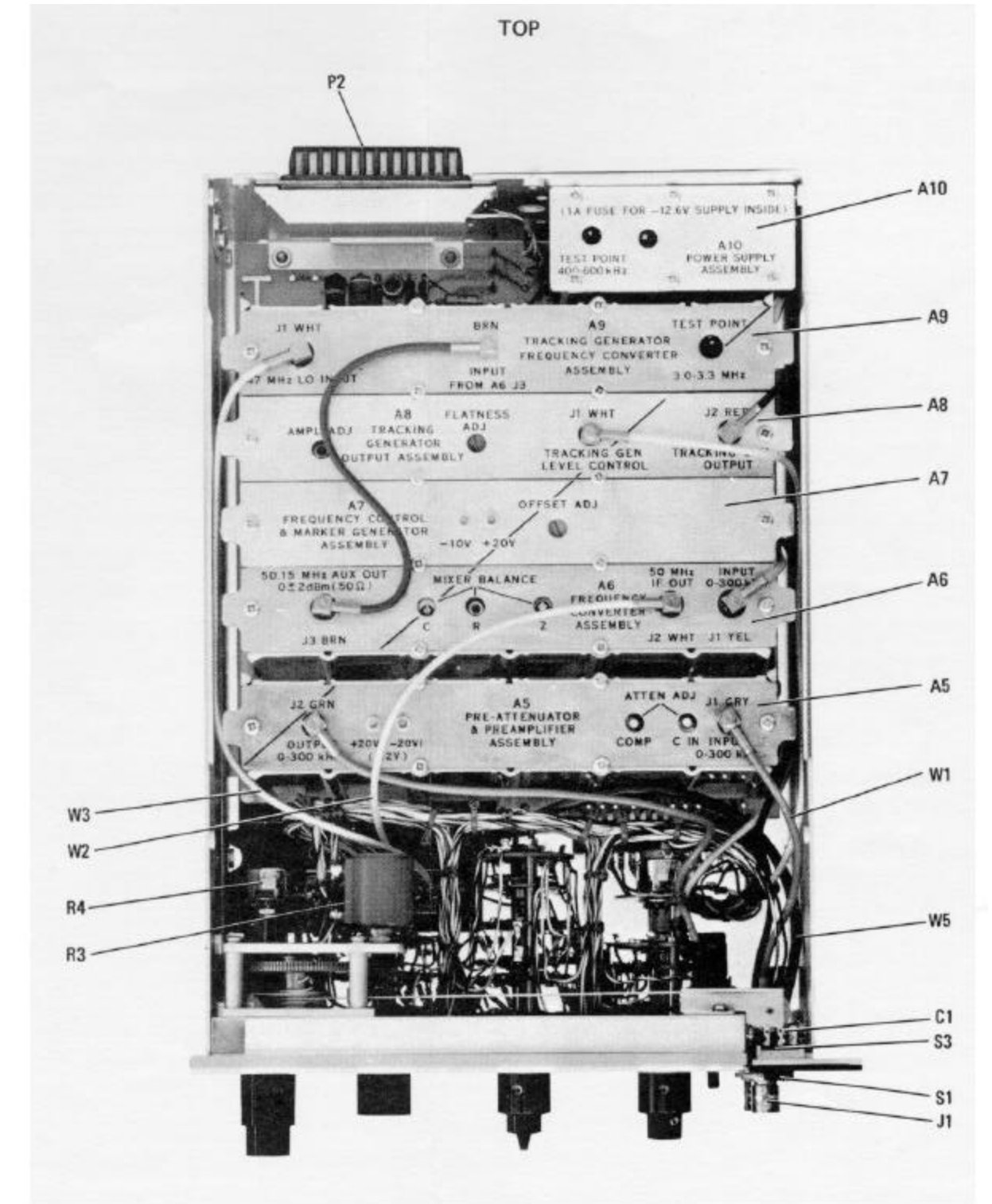
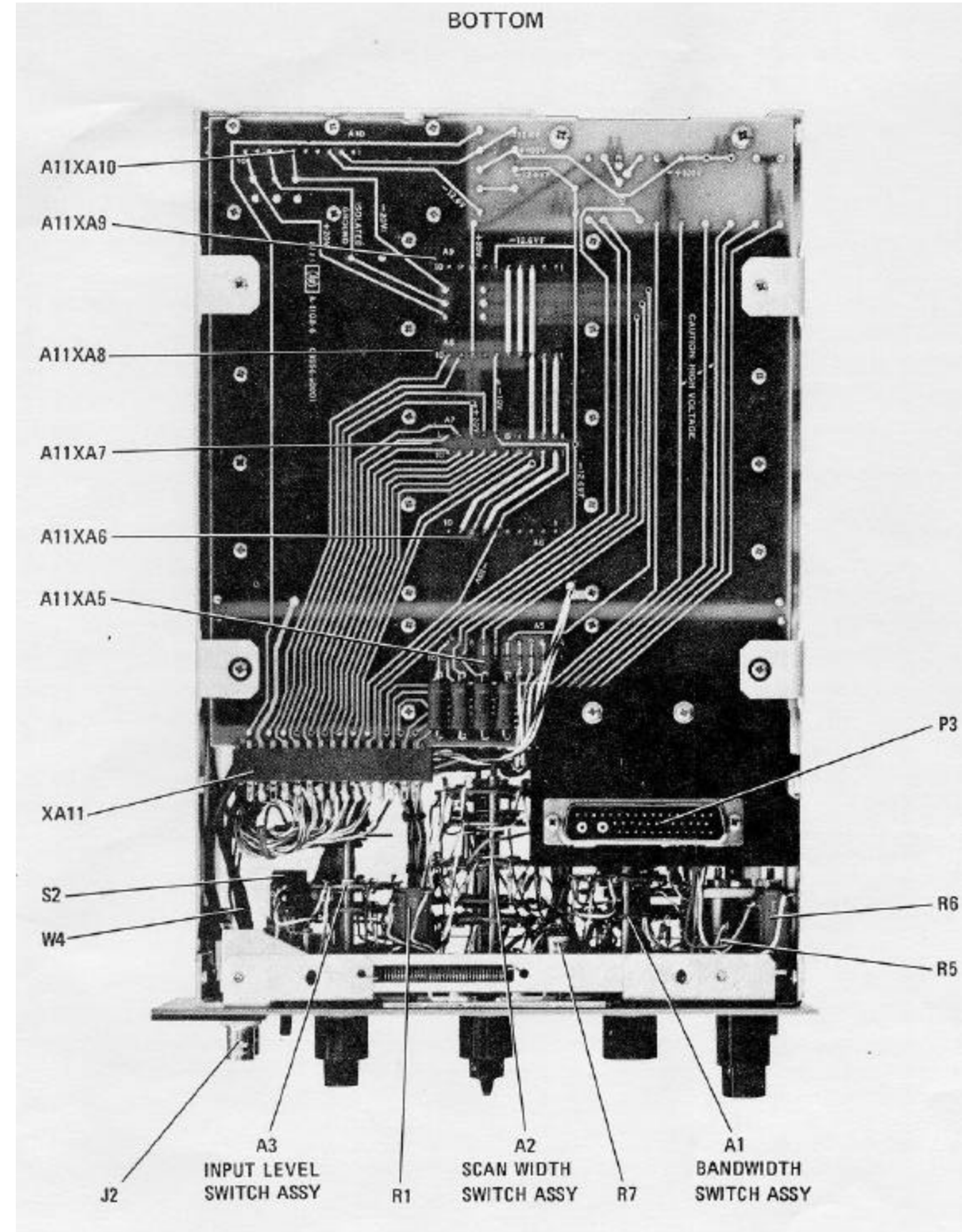

Figure 8-14. Top and Bottom Internal Views

Table 8-5. Connector P2 Pin Identification

Connector P2	Wire Color Code	Function
Pin 1	-	Connects to Pin 4
2	92	+100 Volts
3	-	Open
4	-	Connects to Pin 1
5-7	-	Open
8	0	-12.6 Volts Ground Return
9	-	Open
10	905	To DISPLAY UNCAL Lamp
11	-	Connects to Pin 12
12	-	Connects to Pin 11
13-15	-	Open
16	92	+100 Volts
17-20	-	Open
21	97	-12.6 Volts
22	-	Open
23	-	Connects to Pin 24
24	-	Connects to Pin 23

Table 8-6. Connector P3 Pin Identification

Connector P3	Wire Color Code	Function
Pin 1	912	0.03 kHz (8552B)/0.05 kHz (8552A) Bandwidth
2	913	0.10 kHz Bandwidth
3	914	0.30 kHz Bandwidth
4	915	1.0 kHz Bandwidth
5	926	Frequency Tune Voltage
6	3	± 5V Scan Sawtooth
7	5	Linear Gain Compensation
8	6	Linear Gain Compensation
9	938	LOG REF LEVEL Lamp No. 4
10	945	LOG REF LEVEL Lamp No. 5
11	946	LOG REF LEVEL Lamp No. 6 (right)
12	90	Sensing Ground
13	-	Open
14	925	0.01 kHz Bandwidth (8552B Only)
15	904	8552A/B Sensing for ZERO ADJ
16-24	-	Open
25	916	10 kHz Bandwidth
26	902	30 kHz Bandwidth (+20V Out)
27	902	100 kHz Bandwidth (+20V Out)
28	-	300 kHz Bandwidth (Open)
29	96	To AMPL CAL Pot
30	957	Normal Analogic Line
31	934	47 MHz LO Scan Voltage
32	9	ZERO ADJ Voltage
33	935	LOG REF LEVEL Lamp No. 1 (left)
34	936	LOG REF LEVEL Lamp No. 2
35	937	LOG REF LEVEL Lamp No. 3
36	907	-10 Volts
37	902	+20 Volts
38	956	VIDEO FILTER Analogic Line
39	958	ZERO SCAN Analogic Disable Line
40	968	LOG/LINEAR Sensing
41	-	Open
A1	Clear	50 MHz IF
A2	Clear	47 MHz Auxiliary Line

Table 8-7. Connector XA11 Pin Identification

Connector XA11	Wire Color Code	Function
Pin 1	-	Open
2	-	Open
3	1	Pre-Atten Relay Coil Return
4	-	Open
5	907	-10 Volts
6	917	0-200 kHz Scan Tune Offset
7	901	RANGE kHz Switch
8	926	Frequency Tune Voltage
9	923	Scan Width Attenuator Input
10	95	Scan-Offset Amplifier Offset Input
11	91	Tune-Offset Amplifier Frequency Tune Input
12	947	TRACK ADJ Supply
13	-	Open
14	-	Open
15	905	To DISPLAY UNCAL Lamp
A	-	Open
B	-	Open
C	2	Pre-Atten Relay Coil Supply
D	968	LOG/LINEAR Sensing
E	97	-12.6 Volts
F	948	RF Markers Switch
H	928	Tune-Offset Amplifier Output
J	98	FINE TUNE Pot
K	927	Voltage - Follower Amplifier Input
L	93	Scan - Offset Amplifier Scan Input
M	902	+20 Volts
N	967	TRACK ADJ Voltage
P	-	Open
R	0	Chassis Ground
S	-	Open

Troubleshooting Block
Diagram & Connector
Identification

SERVICE SHEET 1

SERVICE SHEET 1

INTRODUCTION

General

The troubleshooting block diagram can be used to quickly isolate trouble to the circuit board, or assembly, level. To implement repair, turn to the service sheet that covers the faulty circuit board and follow the troubleshooting procedure.

Related Adjustments

After repairing a circuit board, perform the adjustment procedures, if any, specified in the troubleshooting procedure.

TROUBLESHOOTING

Equipment

- Oscilloscope HP 180A/1801A/1820B
- X10 Oscilloscope Probe HP 10004A
- Digital Voltmeter ... HP 3480B/3484A, Option 042
- Cable Assy HP 11002A
- Test Oscillator HP 651B
- BNC Cable Assy (2) HP 10503A
- Adapter HP 1250-1236
- Adapter HP 1250-1237
- Extender Cable Assy HP 11592-60015
- Interconnection Cable Assy HP 11592-60016

Extender Cable Installation

Push the front panel latch in the direction indicated by the arrow until the latch disengages and pops out from the panel. Pull the plug-ins out of the instrument. Locate the black press-to-release button on the right side of the LF Section. Press the button and firmly pull the two sections apart. When the two sections separate at the front panel, raise the upper section until it is above the lower section by two or three inches at the front panel. Disengage the metal tab-slot connection at the rear and separate the sections. Remove top and bottom covers from the LF Section.

Place the plate end of the HP 11592-60015 Extender Cable Assembly in the Display Section and press firmly into place so that the plugs make contact. The plate and plugs cannot be installed upside down as the plate has two holes corresponding to the two guide rods in the mainframe.

Connect the upper cable plug to the LF Section and the lower cable plug to the IF Section. The plugs are keyed so that they will go on correctly and will not make contact upside down. Connect HP 11592-60016 Interconnection Cable Assembly between the LF and IF Sections. The connectors on the cable are keyed by the shape of the plug and the arrangement of the pins. Press the connectors firmly together and extend the instruments as far apart as the cable will allow without putting stress on the connectors.

Measurement Procedure

Set the analyzer controls as specified on the block diagram. Set the Test Oscillator for the signal shown and apply the signal to INPUT. Apply power to the analyzer.

NOTE

The meter on the HP 651B Test Oscillator is calibrated to read volts into 50 (or 600) ohms. If the oscillator is terminated in a high impedance, such as the analyzer INPUT, its meter will read one-half the applied voltage. Use a 50-ohm Feed Thru termination or set the oscillator for half the desired voltage.

Check the dc voltages shown with a Digital Voltmeter. If the voltages are incorrect, see Service Sheet 12.

Check the waveforms shown with an oscilloscope: use a BNC cable and adapters to check waveforms at cable plugs and jacks, and use the X10 probe to check waveforms at test points and circuit board connector pins (connector pins are available on the bottom of 8556A chassis).

Follow the instructions listed under waveforms. For example, check the signal at A6J3 by removing the brown cable (A9W1) from jack A6J3 and connecting an oscilloscope to the jack with an adapter and a BNC cable.

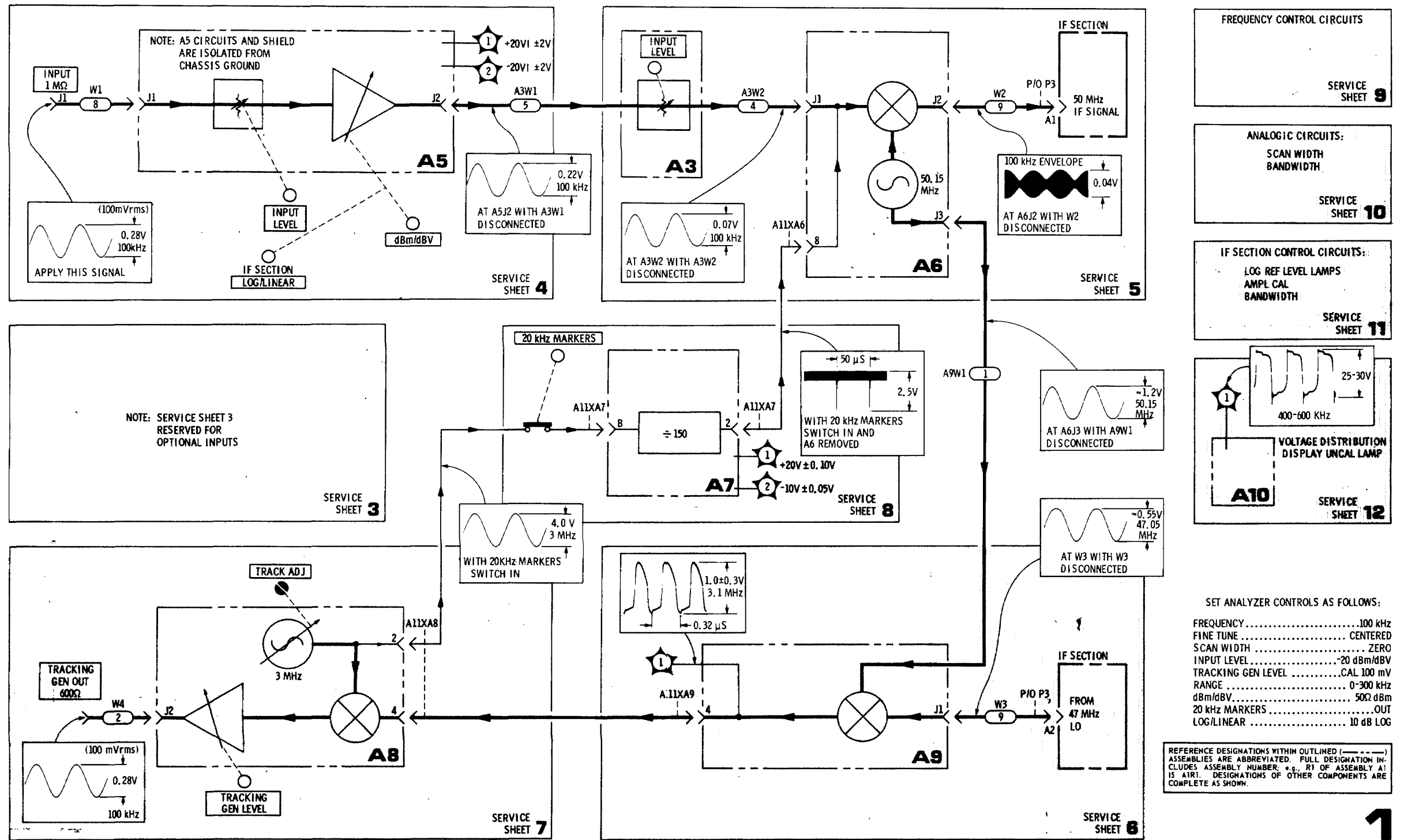

SERVICE SHEET 2

SIMPLIFIED ANALYZER BLOCK DIAGRAM

The Hewlett-Packard Model 8556A LF Section was designed to be used with an 8552 series IF Section and a 140 series Display Section. When the three units are combined they function as a low frequency spectrum analyzer. The analyzer operates like a swept receiver. It electronically scans an input signal and displays the frequency and amplitude of its composite components on a CRT.

The analyzer's tuning section, the 8556A, contains circuits that amplify the signal and shift its frequency to put it in the IF passband. The LF Section also has a tracking generator and a marker generator.

The IF Section contains a local oscillator that is swept, in frequency, by the same sawtooth that sweeps the CRT. This swept LO is mixed with the signal from the LF Section; the resulting 3 MHz signal passes through bandwidth shaping circuits, a log/linear amplifier, a rectifier, and is sent to the Display Section.

The Display Section has a CRT that displays the signal's amplitude vs. its frequency. Because the amplifiers and oscillators in the analyzer are calibrated, the signal's voltage (mV, uV, dBV) or power (dBm) and frequency can be read directly on the CRT.

LF SECTION BLOCK DIAGRAM

Pre-Attenuator and Preamplifier

The input signal passes through the pre-attenuator to the preamplifier. The pre-attenuator has 0 or 30 dB of attenuation, depending upon the position of the INPUT LEVEL switch. The preamplifier has a high impedance input and its gain depends upon the way the signal's amplitude is being measured; the gain is set by the IF Section LOG/LINEAR switch and the LF Section dBm/dBV switch.

Post-Attenuator and Frequency Converter

From the preamplifier the signal is fed through the post-attenuator and a low pass filter to a balanced mixer. The post-attenuator works in conjunction with the pre-attenuator. Together they attenuate the input signal from 0 to 50 dB depending upon the setting of the INPUT LEVEL switch. This attenuation reduces spurious mixing products in the mixer, insuring that the mixer is not over-driven.

The low pass filter prevents high frequency signals from reaching the mixer; its cut-off frequency is about 1 MHz. The balanced mixer combines the 20 Hz to 300 kHz input with 50.150 MHz from the crystal oscillator. The difference frequency is fed through the buffer amplifier to the IF Section.

20 kHz Marker Circuits

When the 20 kHz MARKERS switch is depressed, 3 MHz from the tracking generator is fed to the marker dividers. This division results in narrow, 20 kHz pulses which are then fed into the input signal path. The 0.33 microsecond width of the pulse ensures that 20 kHz markers will extend to 300 kHz with no significant amplitude decrease.

Block Diagram

SERVICE SHEET 2 →

Service

Model 8556A

SERVICE SHEET 2 (cont'd)

Frequency Control Circuits

The frequency of the 47 MHz LO (located in the IF Section) is determined by:

- a. The voltage from the voltage follower.
- b. The voltage from the scan-offset amplifier and scan width attenuator.
- c. The voltage from the ZERO ADJ pot.

When SCAN WIDTH is set to PER DIVISION or ZERO, the voltage to the voltage follower is determined by the output of the tune-offset amplifier (which sums the voltages from the FREQUENCY and FINE TUNE controls), and by the RANGE switch. In 0-10f, the input to the voltage follower is pre-set.

When SCAN WIDTH is set to PER DIVISION or 0-10f, the ramp from the IF Section is processed by the scan-offset amplifier and attenuated by the scan width attenuator (attenuation is in proportion to the PER DIVISION setting). This ramp then sweeps the 47 MHz LO. The ramp is not used when SCAN WIDTH is set to ZERO.

Tracking Generator Frequency Converter

The tracking generator produces a signal which precisely tracks the spectrum analyzer tuning frequency. The signal from the 47 MHz LO in the IF Section is fed through an amplifier to a balanced mixer. There it is mixed with 50.150 MHz from the frequency converter. The difference frequency (3-3.3 MHz) is filtered, amplified and fed to another balanced mixer.

Tracking Generator Output

The balanced mixer mixes 3 MHz from the crystal oscillator with 3 to 3.3 MHz from the frequency converter. The crystal oscillator can be tuned to center the tracking generator signal in the IF passband. The difference frequency from the balanced mixer is filtered and sent to the output amplifier. The gain of the amplifier is controlled by the TRACKING GEN LEVEL control. The amplifier's output is 100 mV in CAL (into an open circuit) and can be increased to about 3 volts.

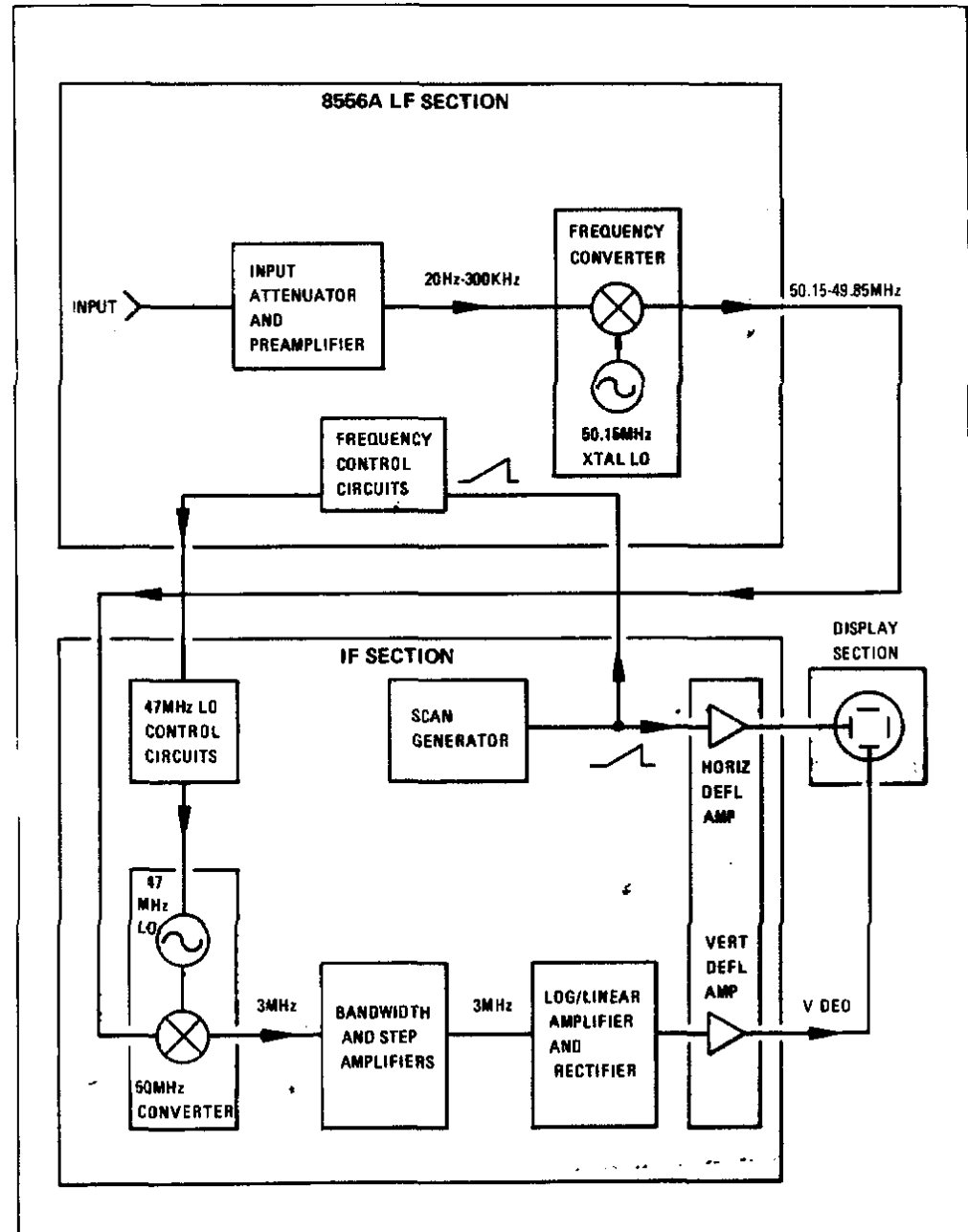

Figure 8-16. Simplified Analyzer Block Diagram

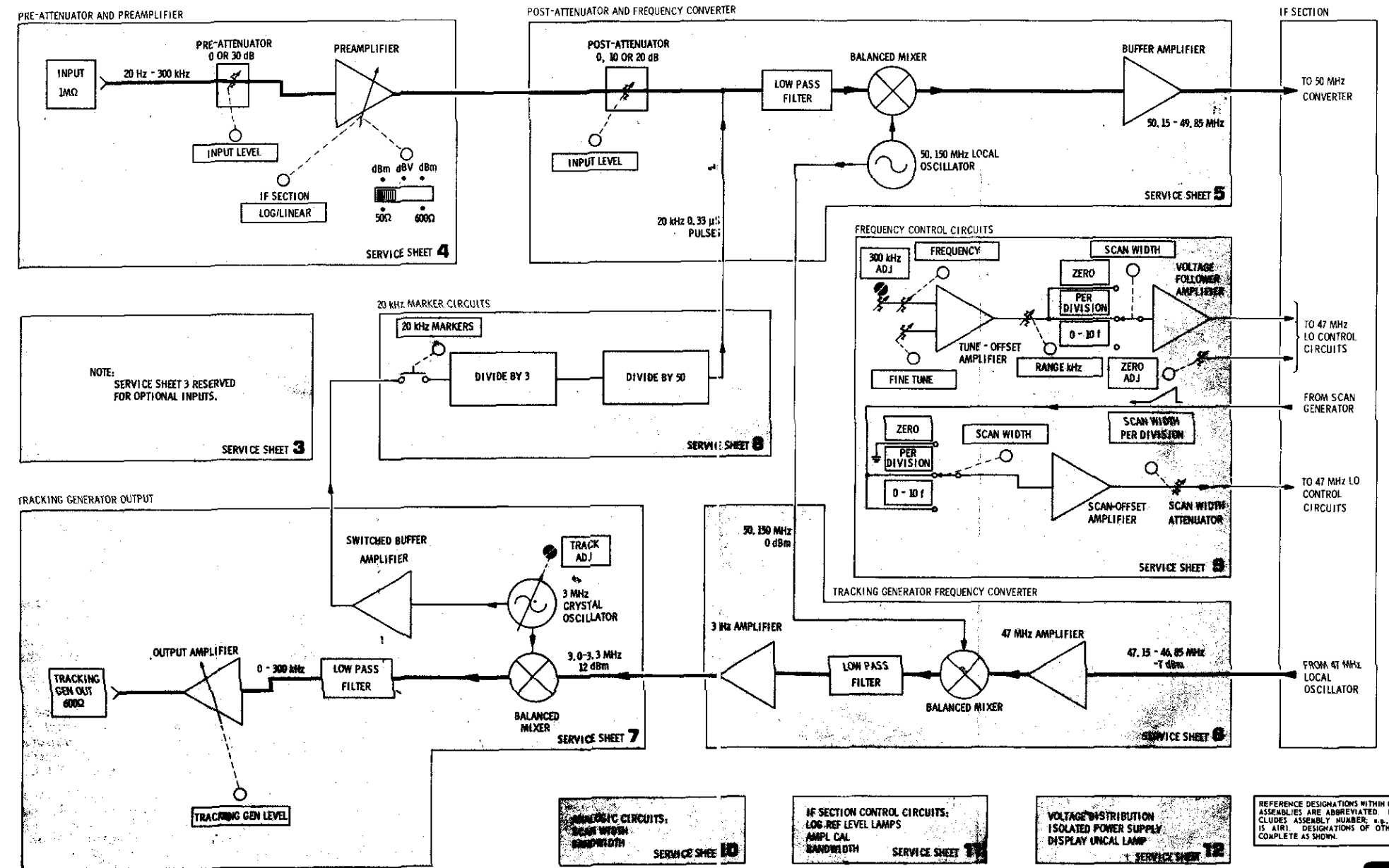

Figure 8-17. LF Section Block Diagram

SERVICE SHEET 4

THEORY OF OPERATION

General

The Pre-Attenuator and Preamplifier Assembly A5 contains the pre-attenuator and the preamplifier, and it is isolated from chassis ground. Preamplifier power is supplied by the Power Supply Assembly A10 (see Service Sheet 12); the isolated ground used by the input circuitry also originates on the A10 assembly.

Pre-Attenuator

The pre-attenuator is used in the last three positions of the INPUT LEVEL switch. The switch controls relay A5K1, and resistors A11R1 and R2 isolate K1 from chassis ground. The pre-attenuator is a 30 dB voltage divider. C IN capacitor A5C6 adjusts attenuator capacitance so that LF Section input capacitance does not change when the attenuator is used. COMP capacitor A5C7 adjusts attenuator flatness. A5R5 and A5CR3 through CR6 protect the preamplifier from input overloads.

Preamplifier

A5Q1 through Q4 and associated circuitry form a feedback amplifier. Q4 is a low noise, junction FET with high input impedance. Q3 is a common base amplifier that matches the low impedance at the drain of Q4 to the high impedance at the base of Q2; this provides high voltage gain. Q2 provides high current gain and some voltage gain. Q1 isolates the collector of Q2 from the A5 assembly's 100 ohm output impedance. The gain of the amplifier is controlled by the feedback from the emitter of Q1 to the source of Q4.

With the LOG/LINEAR switch on the IF Section set to LINEAR, open circuit gain is 8 dB. With LOG/LINEAR set to LOG (either 2 dB or 10 dB), -12.6 V turns on All1Q1, which turns on A5K2. This adds the feedback divider to the amplifier, and the dBm/dBV switch controls amplifier feedback through A5R7, R8 and R9. Therefore, the gain of the amplifier depends upon the settings of the LOG/LINEAR and the dBm/dBV switches.

TROUBLESHOOTING

Equipment:

Digital VoltmeterHP 3480B/3484A Option 042
Test OscillatorHP 651B
AC VoltmeterHP 400EL
BNC Cable Assy (2)HP 10503A
Cable AssyHP 11002A
Adapter HP 1250-1236
Extender Cable AssyHP 11592-60015
Extender Board HP 5060-0256

General

Normally trouble is isolated to the Pre-Attenuator and Preamplifier Assembly A5 using the overall troubleshooting tree or the troubleshooting block diagram. Isolate trouble to the circuit level using the troubleshooting tree and procedures outlined below. The voltages listed on the schematic should assist in isolating trouble to a specific component.

SERVICE SHEET 4 (cont'd)

Supply Voltages and Isolation

With Digital Voltmeter measure voltage at +20 VI and -20 VI test points on assembly cover. The voltages should be $+20 \pm 2$ V and -20 ± 2 V. Connect test leads from assembly cover to chassis ground and measure resistance; it should be about 100K ohms.

If either of the above checks are out of limits, remove A5 assembly from chassis and re-check (voltages will be $+28 \pm 4$ V and -28 ± 4 V.) If checks are still out of limits, see Service Sheets 5 and 12.

Pre-Attenuator

Connect AC Voltmeter to A5J2 (OUTPUT) and Test Oscillator to analyzer INPUT (on front panel). Set oscillator for a 3 kHz signal and check that attenuation is 30 dB ± 0.20 dB when INPUT LEVEL is switched from -40 dBm/dBV to -30 dBm/dBV. Set oscillator to 300 kHz and again check attenuation.

If the checks outlined above indicate pre-attenuator malfunction, remove A5 assembly from chassis and re-install on extender board. Check that relay A5K1 is operating correctly, then check components in 30 dB pad. After repairing pre-attenuator, perform adjustments specified in paragraph 5-24.

Preamplifier

Connect Test Oscillator directly to AC Voltmeter; set oscillator for 3 kHz and a -30.00 dB reading on voltmeter (about 25mV). Connect oscillator to analyzer INPUT and connect voltmeter to A5J2 (OUTPUT). Don't change oscillator signal amplitude. Set INPUT LEVEL switch to -40 dBm/dBV and LOG/LINEAR switch to LINEAR. The voltmeter should read -22.00 dB ± 0.20 dB (for a preamplifier open circuit gain of 8 dB).

Set LOG/LINEAR switch to LOG and dBm/dBV switch to dBV. The voltmeter should read -15.00 ± 0.20 dB (for a pre-amplifier open circuit gain of 15 dB).

Set dBm/dBV switch to 6002 dBm. The voltmeter should read -12.88 dB ± 0.20 dB (for a preamplifier open circuit gain of 17.22 dB).

Set dBm/dBV switch to 50Q dBm. The voltmeter should read -2.00 dB ± 0.20 dB (for a preamplifier open circuit gain of 28 dB). Repeat the checks with oscillator set to 300 kHz.

NOTE

If using 8552B IF Section with serial prefix 977 and below, or 8552A with serial prefix 991 and below, check that IF Section connectors XA8 pin 8 and J3 pin 40 are connected together (should be electrical short). If not, connect them with a length of 968 (white-blue-grey) wire (24 AWG).

If the checks outlined above indicate preamplifier malfunction, remove A5 assembly from chassis and re-install on extender board. Check that relay A5K2 is operating correctly; check dBm/dBV switch S1 and A5Q1 through Q4. After repairing preamplifier, perform mixer balance adjustments specified in paragraph 5-26.

Pre-Attenuator and Pre-Amplifier
SERVICE SHEET 4 →

Service

Model 8556A

SERVICE SHEET 4 (cont'd)

Troubleshooting Tree

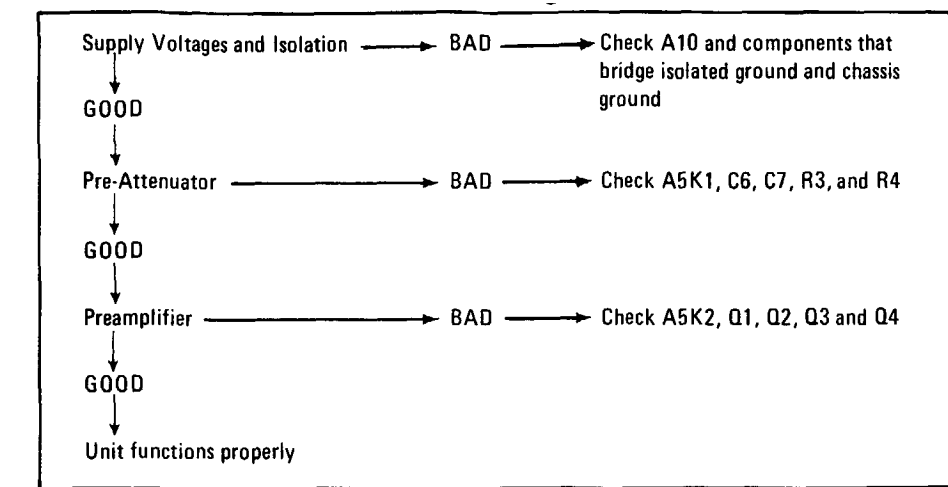

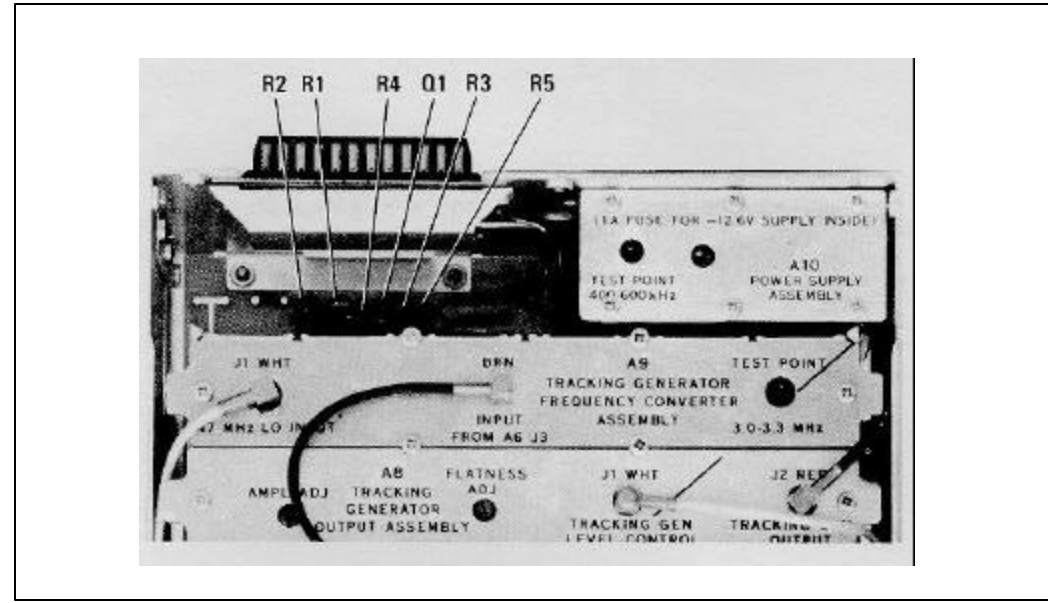

Figure 8-21. Master Board Assembly A11 Component Locations

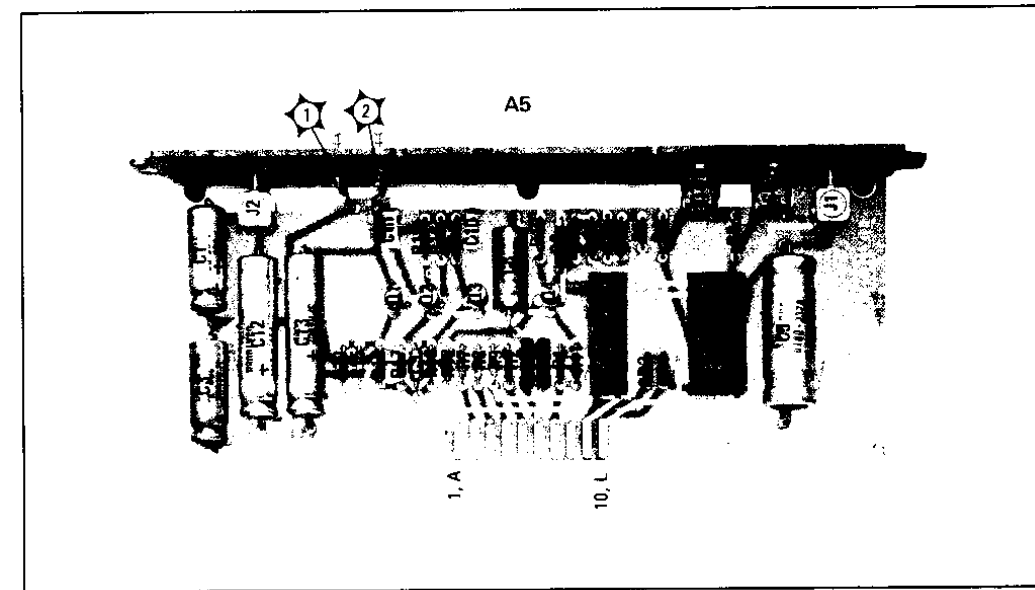

Figure 8-22. Pre-Attenuator and Preamplifier Assy A5 Component Locations

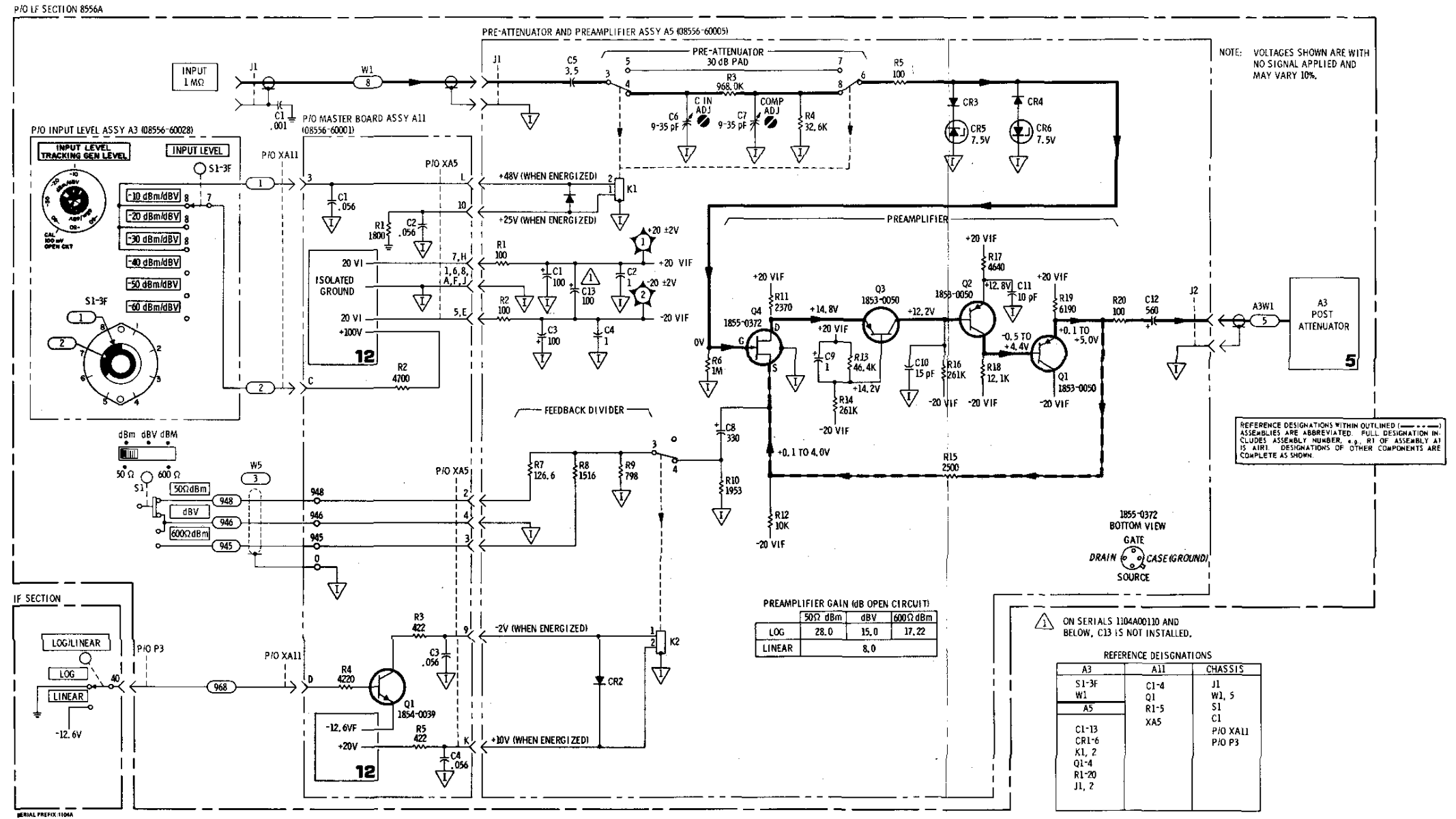

Figure 8-23. Pre-Attenuator and Preamplifier: A3, A5 and A11

SERVICE SHEET 5

THEORY OF OPERATION

General

The post attenuator operates in conjunction with the pre-attenuator to control the level of signals reaching the balanced mixer. If INPUT LEVEL is always set to the level of the input signal, distortion in the mixer will be minimum. Isolated ground (see Service Sheets 4 and 12) continues into Input Level Assembly A3 and into Frequency Converter Assembly A6 to the mixer.

Post Attenuator

The post attenuator contains a 20 dB L-pad, a 10 dB L-pad and a straight through connection. They are selected sequentially (0, 10 dB, 20 dB, 0, 10 dB, 20 dB) as INPUT LEVEL is turned counterclockwise. Each L-pad is a simple voltage divider with an impedance of 100 ohms.

Low Pass Filter

The signal from the post attenuator is fed into a low pass filter. Its cut-off frequency is about 1 MHz and its input and output impedance is 100 ohms. The 20 kHz markers, when used, join the signal path at the filter (see Service Sheet 8).

Balanced Mixer

The dual balanced mixer has a matched diode quad and adjustments to null local oscillator feedthrough. The diode quad is composed of four, matched hot carrier diodes and carrier suppression is about 90 dB when properly balanced.

Buffer Amplifier

The buffer amplifier isolates the balanced mixer from the IF Section. The amplifier input has an impedanced matching circuit and its gain is about 2 dB.

50.150 MHz Local Oscillator

The 50.150 MHz local oscillator is a crystal controlled Colpitts. Feedback is through the capacitive voltage divider in the tank circuit. The oscillator output is fed through A6Q3 to the mixer; Q3 has a voltage gain of about 2. The output is fed to the tracking generator through A6Q1; Q1 has slightly less than unity gain.

TROUBLESHOOTING

Equipment:
 Oscilloscope HP 180A/1801A/1820B
 X10 Oscilloscope Probe HP 10004A
 Digital Voltmeter HP 3480B/3484A Option 042
 Test Oscillator HP 651B
 AC Voltmeter HP 400 EL
 BNC Cable Assy (2) HP 10503A
 Cable Assy HP 11002A

SERVICE SHEET 5 (cont'd)

Adapter HP 1250-1236
 Adapter HP 1250-1237
 Extender Cable Assy HP 11592-60015
 Extender Board HP 5060-0256

General

Normally trouble is isolated to the post attenuator and the Frequency Converter Assembly A6 using the overall troubleshooting tree or the troubleshooting block diagram. Isolate trouble to the circuit level using the troubleshooting tree and procedures outlined below. The voltages listed on the schematic should assist in isolating trouble to a specific component. Extend the LF and IF Sections on the extender cables; remove the A6 assembly from the chassis and re-install it on the extender board.

Isolation

Disconnect yellow cable (A3W2) from A6J1 (INPUT); using Digital Voltmeter, measure resistance from outer conductor of J1 to chassis ground. The voltmeter should indicate an open circuit. If it indicates less than an open circuit, check components in low pass filter and balanced mixer, especially capacitors that bridge isolated ground and chassis ground.

Post Attenuator

Connect Test Oscillator to analyzer INPUT. Connect AC Voltmeter to yellow cable (A3W2) with adapter. Set analyzer INPUT LEVEL to -60 dBm/dBV and adjust oscillator for 0 dBm reference on voltmeter (at about 3 kHz). Check that voltmeter reads as follows while switching INPUT LEVEL:

INPUT LEVEL	Voltmeter
-60 dBm/dBV	0 dB (reference)
-50 dBm/dBV	- 10 dB +0.2 dB
-40 dBm/dBV	- 20 dB +0.2 dB
-30 dBm/dBV	- 30 dB (reference)
-20 dBm/dBV	- 40 dB +0.2 dB
-10 dBm/dBV	- 50 dB +0.2 dB

If the checks outlined above indicated post attenuator malfunction, check components associated with post attenuator on Input Level Assembly A3.

Low Pass Filter

Connect Test Oscillator to analyzer INPUT; connect Oscilloscope (with X10 probe) to test point A (junction of A6C10, L7, R2 and T3). Set analyzer controls as follows:

INPUT LEVEL -30 dBm/dBV
 dBm/dBV 50 Ω dBm
 LOG/LINEAR LOG

Set oscillator for 3 kHz, 200 mV signal (at the 50 ohm output).

Service

Model 8556A

SERVICE SHEET 5 (cont'd)

NOTE

The meter on the HP 651B Test Oscillator is calibrated to read volts into 50 (or 600) ohms. If the oscillator is terminated in a high impedance, such as the analyzer INPUT, its meter will read one-half the applied voltage. Use a 50-ohm Feed Thru Termination or set the oscillator for half the desired voltage.

Check that yellow cable (A3W2) is connected to A6J1 (INPUT). Signal at test point A should be 3 kHz sine wave at approximately 0.2 V p-p. If signal level is incorrect check components in low pass filter. After repairing low pass filter, perform mixer balance adjustments specified in paragraph 5-26.

50.150 MHz Local Oscillator

Connect Oscilloscope (with X10 probe) to test point C (A6Q1-c). Signal should be 50.150 MHz sine wave, 0.9 V to 1.6 V p-p (with brown cable to A6J3 disconnected). Connect probe to test point B (A6Q3-c); signal should be 50.150 MHz sine wave, 3.2 V to 4.8 V p-p. (In both cases, frequency should be 50.150 MHz +3.0 kHz).

If signal is incorrect at one test point but not at both, check appropriate amplifier. If signal is incorrect at both test points, check A6Q2 and associated components. After repairing oscillator, perform 50.150 oscillator adjustment specified in paragraph 5-25 and mixer balance adjustments specified in paragraph 5-26.

Balanced Mixer

Connect Test Oscillator to analyzer INPUT; connect Oscilloscope (with X10 probe) to test point D (junction of A6T3, C22, C23 and L9).

Set analyzer controls and Test Oscillator as specified in low pass filter test. Signal at test point D should be 3 kHz modulation envelope as shown on schematic. Envelope amplitude at test point E (J2) should be approximately 0.4 V p-p with clear cable at J2 disconnected. If envelope amplitude is incorrect, check components in buffer amplifier. After repairing amplifier, perform mixer balance adjustments specified in paragraph 5-26.

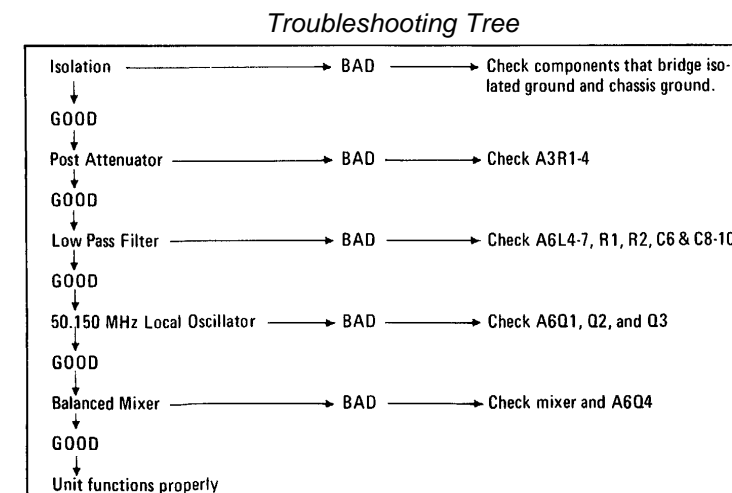

Post Attenuator and Frequency Converter
SERVICE SHEET 5 →

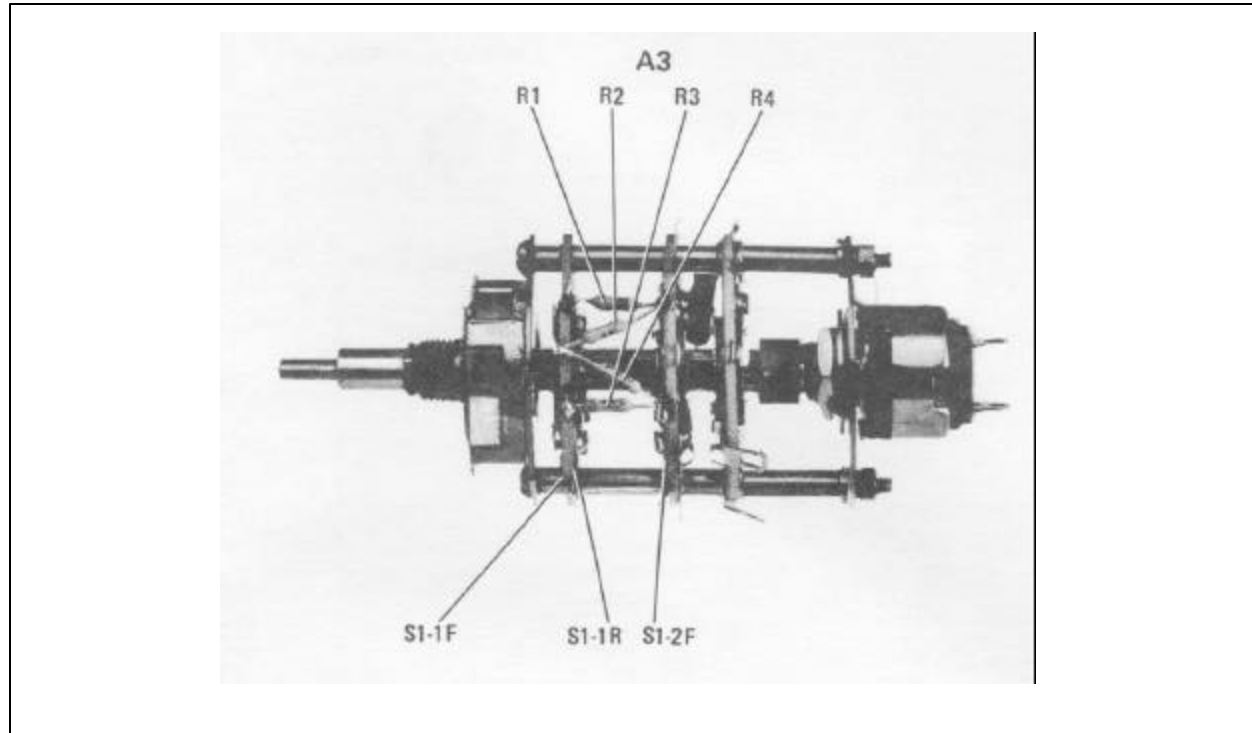

Figure 8-24. Input Level Switch Assembly A3 Component Locations

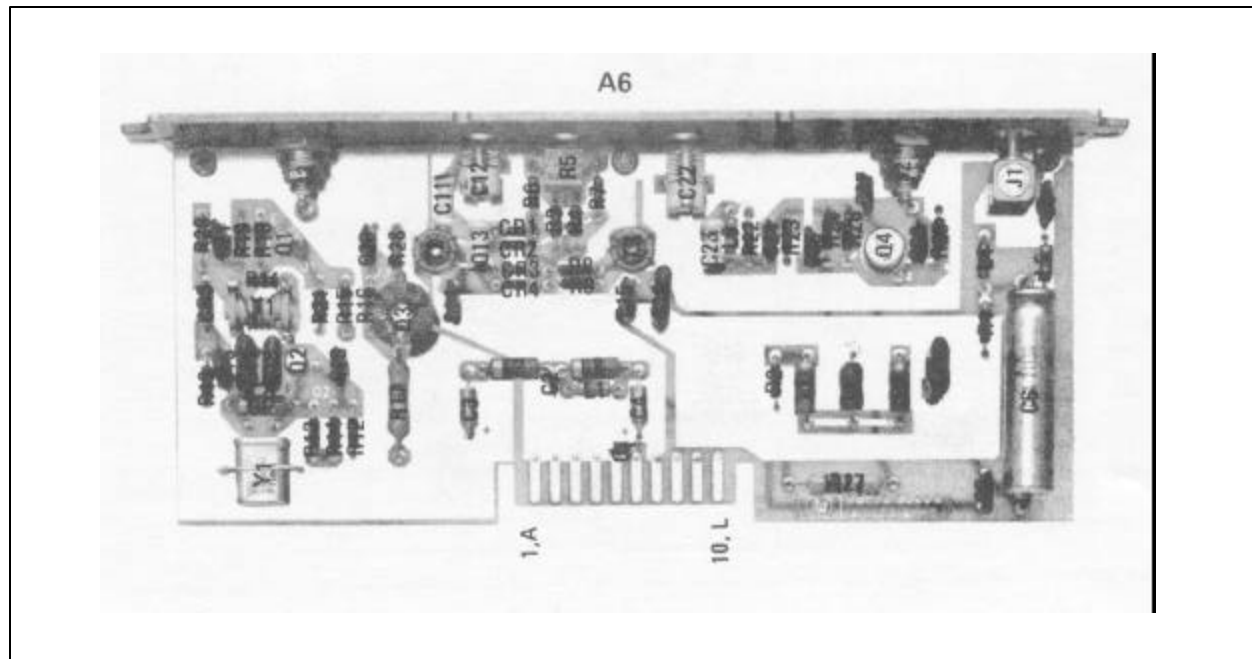

Figure 8-25. Frequency Converter Assy A6 Component Locations

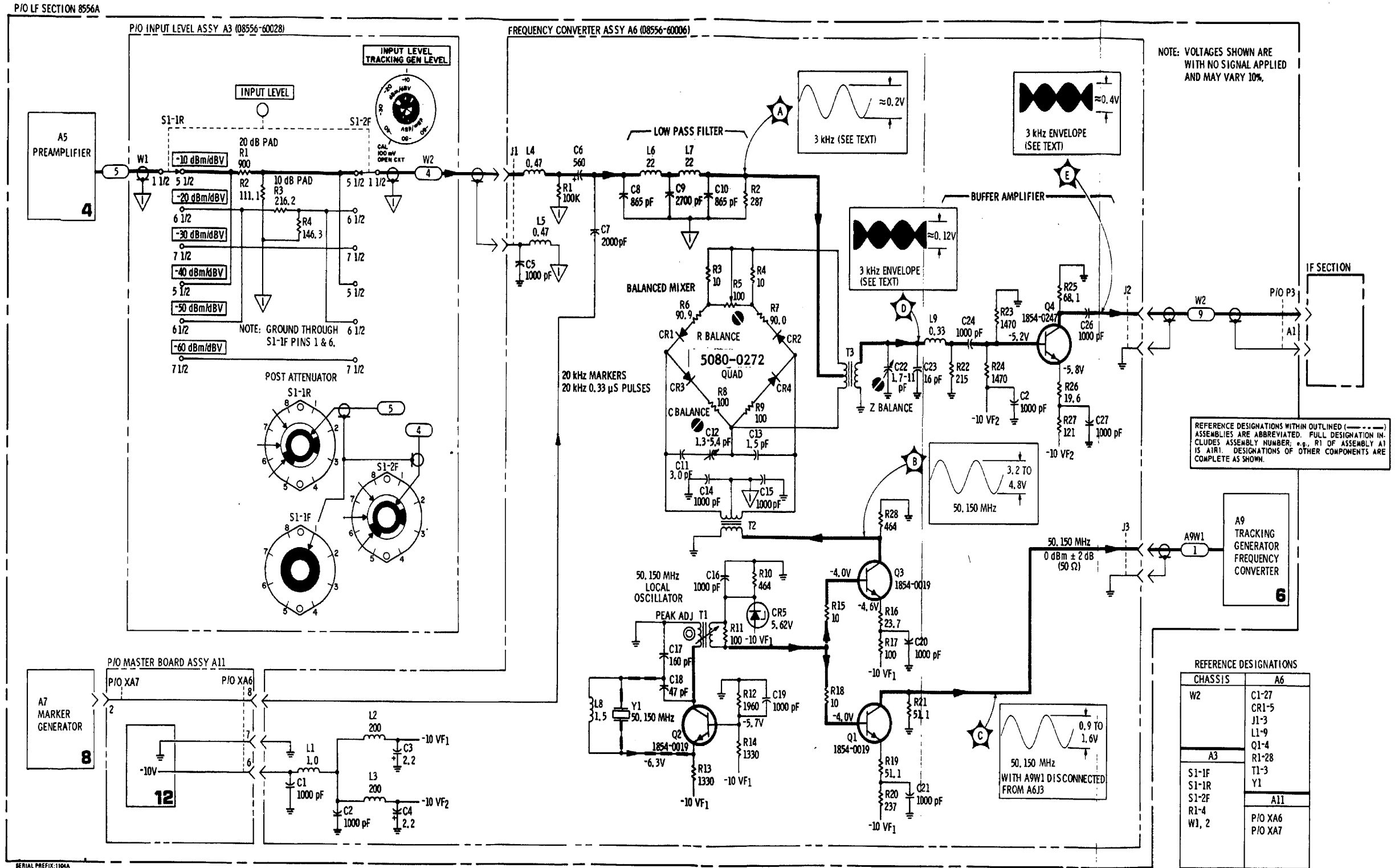

Figure 8-26. Post-Attenuator & Frequency Converter: A3 and A6

SERVICE SHEET 6

THEORY OF OPERATION

General

The tracking generator produces a signal that precisely tracks the spectrum analyzer tuning frequency. It does this by combining the 47 MHz LO from the IF Section with the 50.150 MHz LO from the LF Section, combining the difference frequency (3 to 3.3 MHz) with 3 MHz, and amplifying the second difference frequency (0 to 300 kHz). The circuits associated with the first frequency conversion are on the Tracking Generator Frequency Converter Assembly A9.

47 MHz Amplifier

The signal at A9J1 is 47 MHz \pm 150 kHz and comes from the IF Section 47 MHz LO. Signal amplitude at J1 is about -7 dBm, and is amplified by A9Q1 and Q2; signal amplitude at the mixer is about 1.2 V p-p.

Balanced Mixer

The dual balanced mixer combines 50.150 MHz from the Frequency Converter Assembly A6 with 47 MHz \pm 150 kHz from the amplifier, takes the 3 to 3.3 MHz difference frequency and feeds it to the low pass filter. Filter cut-off frequency is about 5 MHz.

3 MHz Amplifier

A9Q3, Q4 and Q5 form the 3 MHz amplifier, and the 3 to 3.3 MHz signal at the amplifier input is about 120 mV. The amplifier increases this to a level of about 1.2 V p-p which is fed to the balanced mixer in the Tracking Generator Output Assembly A8.

TROUBLESHOOTING

Equipment:

Oscilloscope	HP 180A/1801A/1820B
X10 Oscilloscope Probe	HP 10004A
Digital Voltmeter	HP 3480B/3484A Option 042
Cable Assy	HP 11002A
Extender Cable Assy	HP 11592-60015
Extender Board	HP 5060-0256

General

Normally trouble is isolated to the Tracking Generator Frequency Converter Assembly A9 using the overall troubleshooting tree or the troubleshooting block diagram. Isolate trouble to the circuit level using the troubleshooting tree and procedures outlined below. The voltages listed on the schematic should assist in isolating trouble to a specific component.

Extend the LF and IF Sections on the extender cables; remove the A9 assembly from the chassis and re-install it on the extender board.

SERVICE SHEET 6 (cont'd)

47 MHz Amplifier

Connect oscilloscope (with X10 probe) to test point A (A9Q1-b). Set SCAN WIDTH to ZERO; signal should be 46.85 to 47.15 MHz sine wave approximately 0.22 to 0.42 V p-p. If not, check 47 MHz Oscillator in IF Section.

Connect oscilloscope (with X10 probe) to test point B (A9Q2-c). Signal should be 46.85 to 47.15 MHz sine wave at approximately 1.2 V p-p. If not, check 47 MHz amplifier circuits.

Balanced Mixer

Connect oscilloscope (with X10 probe) to test point C (A6Q3-b). Set SCAN WIDTH to ZERO. Signal should be 3.0 to 3.3 MHz sine wave at approximately 0.35 V p-p. If not, check balanced mixer and low pass filter circuits.

3 MHz Amplifier

Connect Oscilloscope (with X10 probe) to test point 1. Set SCAN WIDTH to ZERO. Signal should be as shown on schematic: 3.0-3.3 MHz, 1.0 \pm 0.3 V p-p. If not, check 3 MHz amplifier circuits.

Troubleshooting Tree

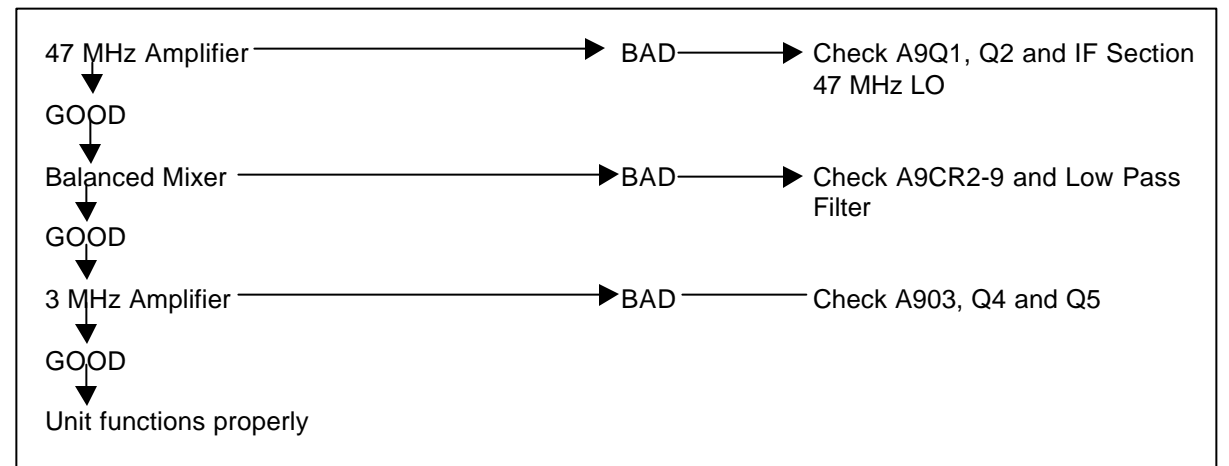

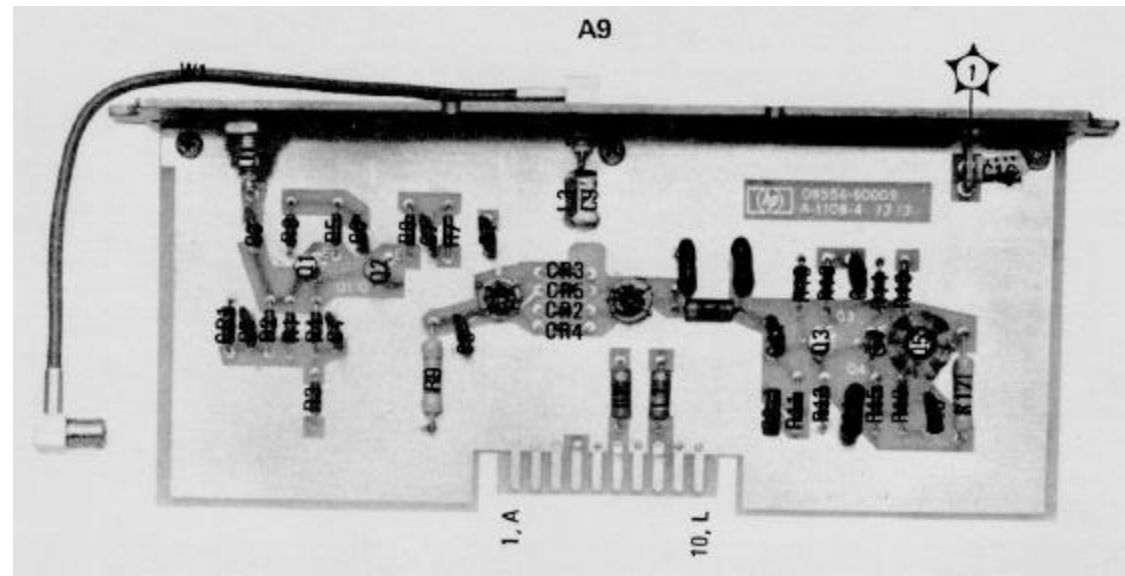

Figure 8-27. Tracking Generator Frequency Converter Assy A9 Component Locations

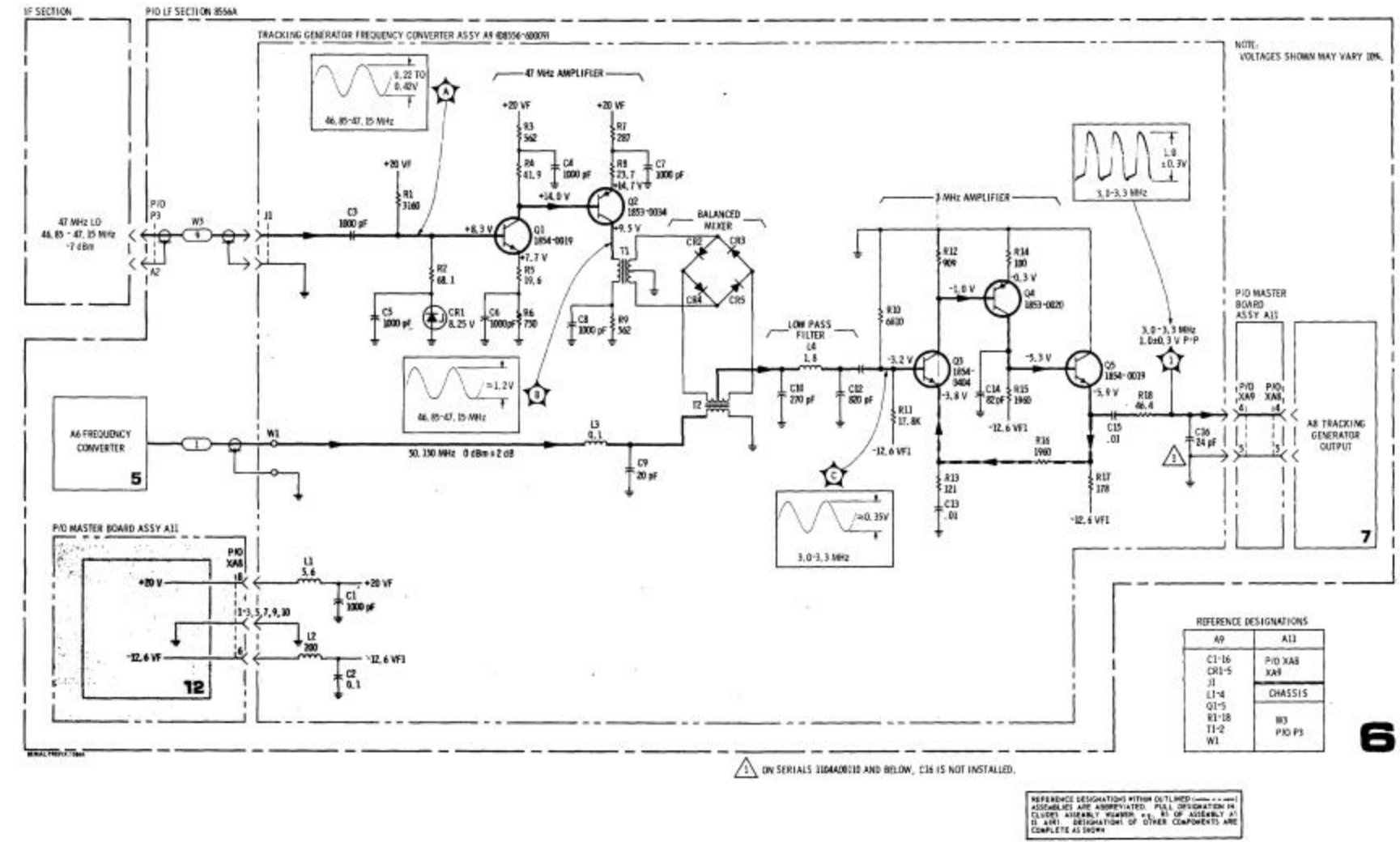

Figure 8-28. Tracking Generator Frequency Converter: A9

SERVICE SHEET 7

THEORY OF OPERATION

General

The tracking generator produces a signal that precisely tracks the spectrum analyzer tuning frequency; 3 to 3.3 MHz from the Tracking Generator Frequency Converter Assembly A9 is mixed with 3 MHz. The difference frequency (0 to 300 kHz) is filtered, amplified, and fed to the front panel.

Balanced Mixer

The balanced mixer combines the 3 to 3.3 MHz signal with 3 MHz from the 3 MHz oscillator and feeds the difference frequency to a low pass filter. The mixer uses a matched diode quad.

3 MHz Oscillator

A8A1Q3 and Q4 form a crystal oscillator. The transistors alternately turn on and off, producing a high amplitude 3 MHz signal.

Varactor A8A1CR7 is used as the fine frequency control element, and the range of varactor control is ± 140 Hz. A8A1L3 is selected to center the range of varactor control at 3 MHz.

A8Q2, CR5 and CR6 limit the 3 MHz signal so that it is flat over the frequency range of the oscillator. The signal level from the balanced mixer depends upon the level of the 3 MHz oscillator signal, so the 3 MHz signal, controlled by AMPL ADJ A8A1R1, is used to amplitude calibrate the tracking generator. Because the mixer's output level is relatively insensitive to changes in signal level from the frequency converter (see Service Sheet 6), tracking generator amplitude calibration is maintained when the LF Section is used with different IF Sections.

Switched Buffer Amplifier

Buffer amplifier A8A1Q1 is normally off. It is activated by negative voltage from the marker generator circuits whenever the 20 kHz MARKERS switch is depressed (see Service Sheet 8). When the amplifier is on it feeds 3 MHz to the marker generator.

Low Pass Filter

A8Q1 is a buffer amplifier that isolates the filter from the mixer. A8Q2 isolates the filter from the output amplifier. FLATNESS ADJ A8R9 in the emitter of Q1 adjusts the flatness of the high end of the filter by varying the filter's input resistance. The filter is flat to 300 kHz.

Output Amplifier

A8Q3 through Q6 form a feedback amplifier. A6 provides enough current so that at maximum signal with the output shorted the amplifier does not clip. Amplifier gain is controlled by TRACKING GEN LEVEL control A3R5; gain is variable from 3 to 100 (10 to 40 dB). When TRACKING GEN LEVEL is full counter-clockwise (CAL 100 mV), the amplifier has a gain of 3 and delivers 100 mV into an open circuit (50 mV into 600 ohms). As TRACKING GEN LEVEL is turned clockwise, A8R12, R13C8, and A3R5 divide the feedback and amplifier gain increases.

SERVICE SHEET 7 (cont'd)

TROUBLESHOOTING

Equipment:

- Digital VoltmeterHP 3480B/3484A Option 042
- AC VoltmeterHP 400EL
- BNC Cable Assy.....HP 10503A
- Cable Assy.....HP 11002A
- Oscilloscope..... HP 180A/1801A/1820B
- X10 Oscilloscope ProbeHP 10004A
- Extender Cable AssyHP 11592-60015
- Extender Board.....HP 5060-0256
- Frequency Counter HP 5327C

General

Normally trouble is isolated to the Tracking Generator Output Assembly A8 using the overall troubleshooting tree or the troubleshooting block diagram. Isolate trouble to the circuit level using the troubleshooting tree and procedures outlined below. The voltages listed on the schematic should assist in isolating trouble to a specific component.

Extend the LF and IF Sections on the extender cables; remove the A8 assembly from the chassis and re-install it on the extender board.

3 MHz Oscillator

Depress 20 (kHz) MARKERS switch and connect Oscilloscope (with X10 probe) to test point C (A11XA8 pin 2); signal should be as shown on schematic: about 3 MHz, 4 V p-p. Connect Frequency Counter to test point C and vary TRACK ADJ, on analyzer front panel, through its full range. Frequency should vary (from 3 MHz) at least ± 140 Hz. (Factory selected component J8A1L3 sets center of variation, see Table 8-1.)

If checks indicate oscillator malfunction, remove cover from 3 MHz Oscillator Assembly A8A1 and check A8A1Q1, Q3, Q4 and associated components. After repairing oscillator, perform tracking generator adjustments specified in paragraph 5-27.

NOTE

A8A1 can usually be repaired without unsoldering entire board. If it becomes necessary to unsolder A8A1, unsolder the six pins with a recommended desoldering tool (see General ;Service Hints). Excess heat or force on pins will pull plating off board.

Balanced Mixer

Connect Oscilloscope (with X10 probe) to test point D (A8Q1-b); signal should be modulation envelope as shown on schematic: about 3 MHz, 0.12 V p-p. If not, remove cover from 3 MHz Oscillator Assembly A8 and check balanced mixer, A8A1Q1 and associated components. After repairing mixer, perform tracking generator adjustments specified in paragraph 5-27.

Service

Model 8556A

SERVICE SHEET 7 (cont'd)

Low Pass Filter

Connect Oscilloscope (with X10 probe) to test point E (A8Q2-e); signal should be 20 Hz to 300 kHz sine wave, approximately 0.1 V p-p. If not, check Q8Q1, Q2 and associated components. After repairing filter, perform tracking generator adjustments specified in paragraph 5-27.

Output Amplifier

Set TRACKING GEN LEVEL to CAL 100 mV and connect oscilloscope to test point F (A8Q6-e); signal should be 20 Hz to 300 kHz sine wave, 0.28 V p-p. If not, check A8Q3 through Q6 and associated components. After repairing amplifier, perform tracking generator adjustments specified in paragraph 5-27.

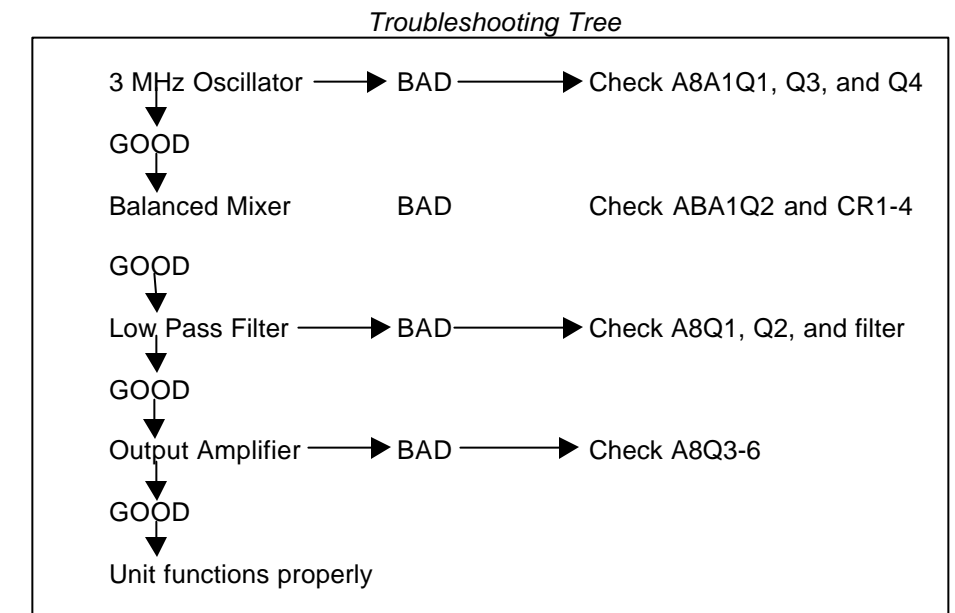

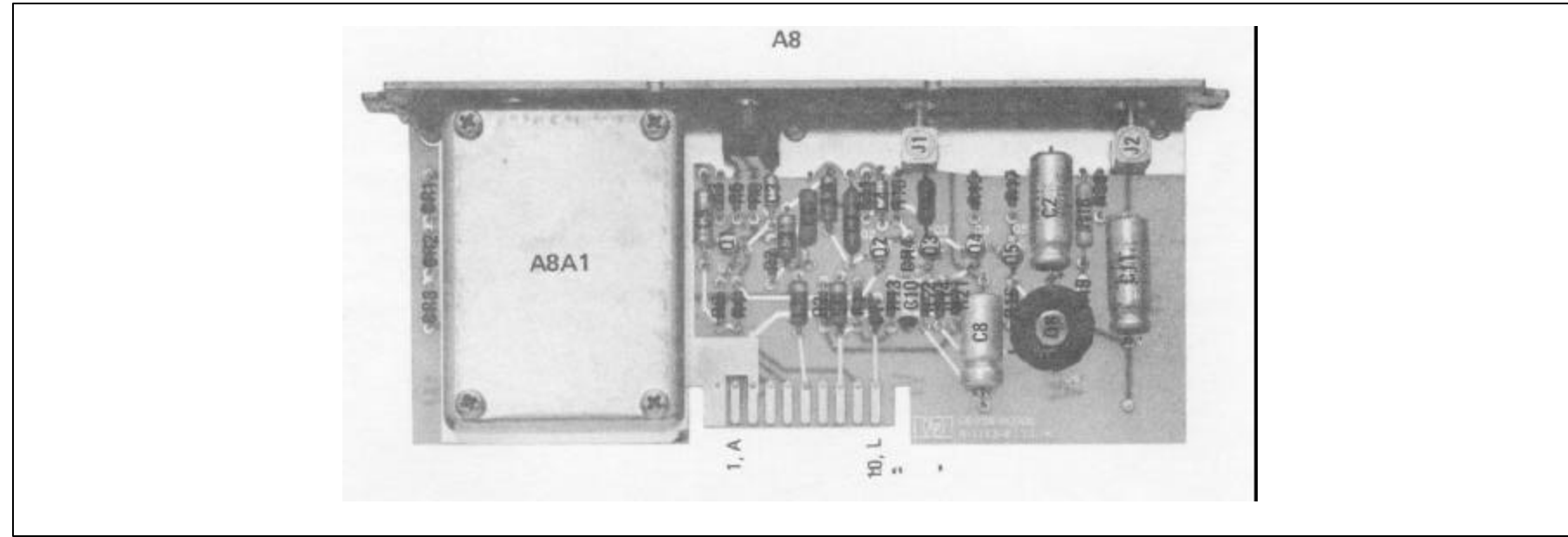

Figure 8-29. Tracking Generator Output Assy A8 Component Locations

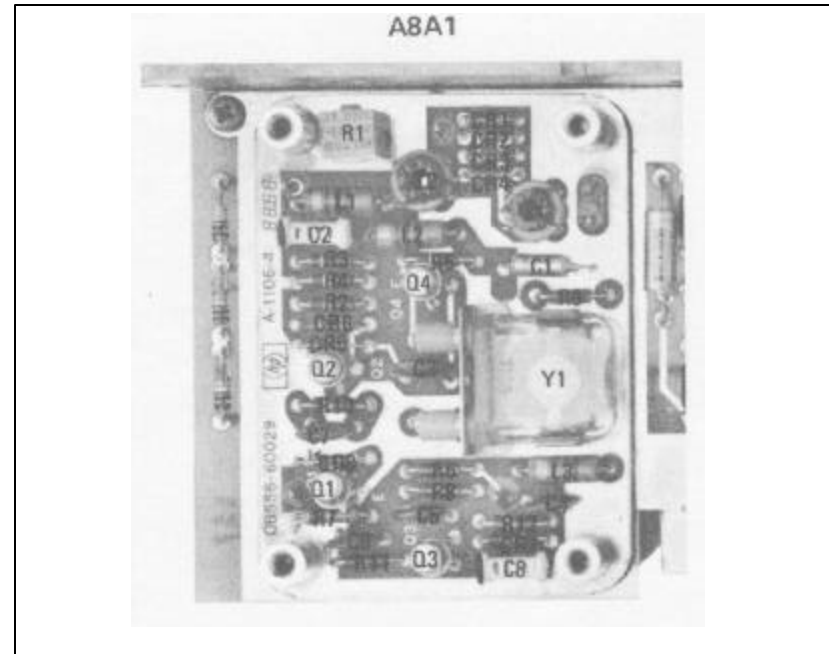

Figure 8-30. 3 MHz Oscillator Assy A8A1 Component Locations

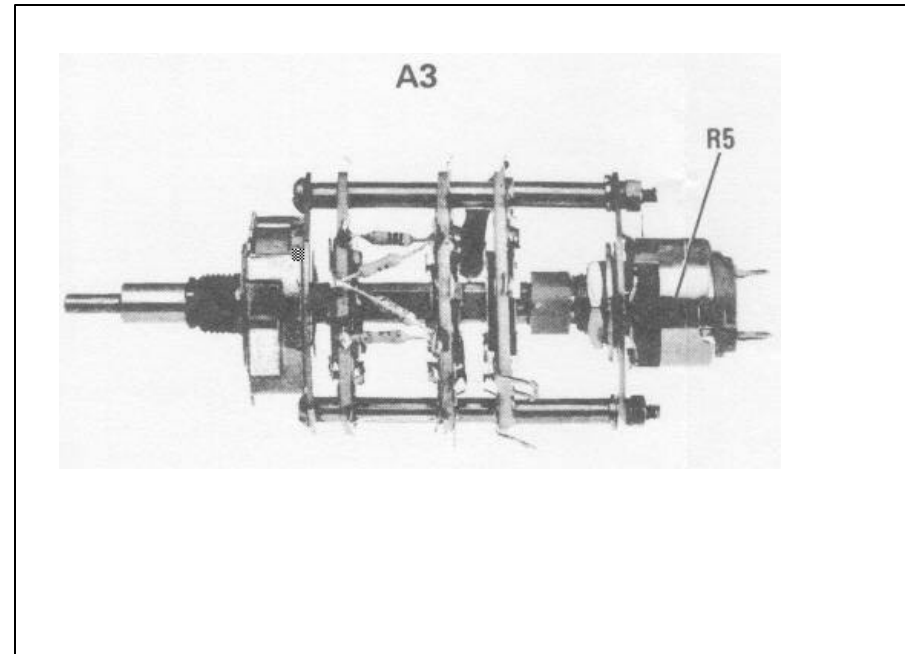

Figure 8-31. Input Level Switch Assy Component Locations

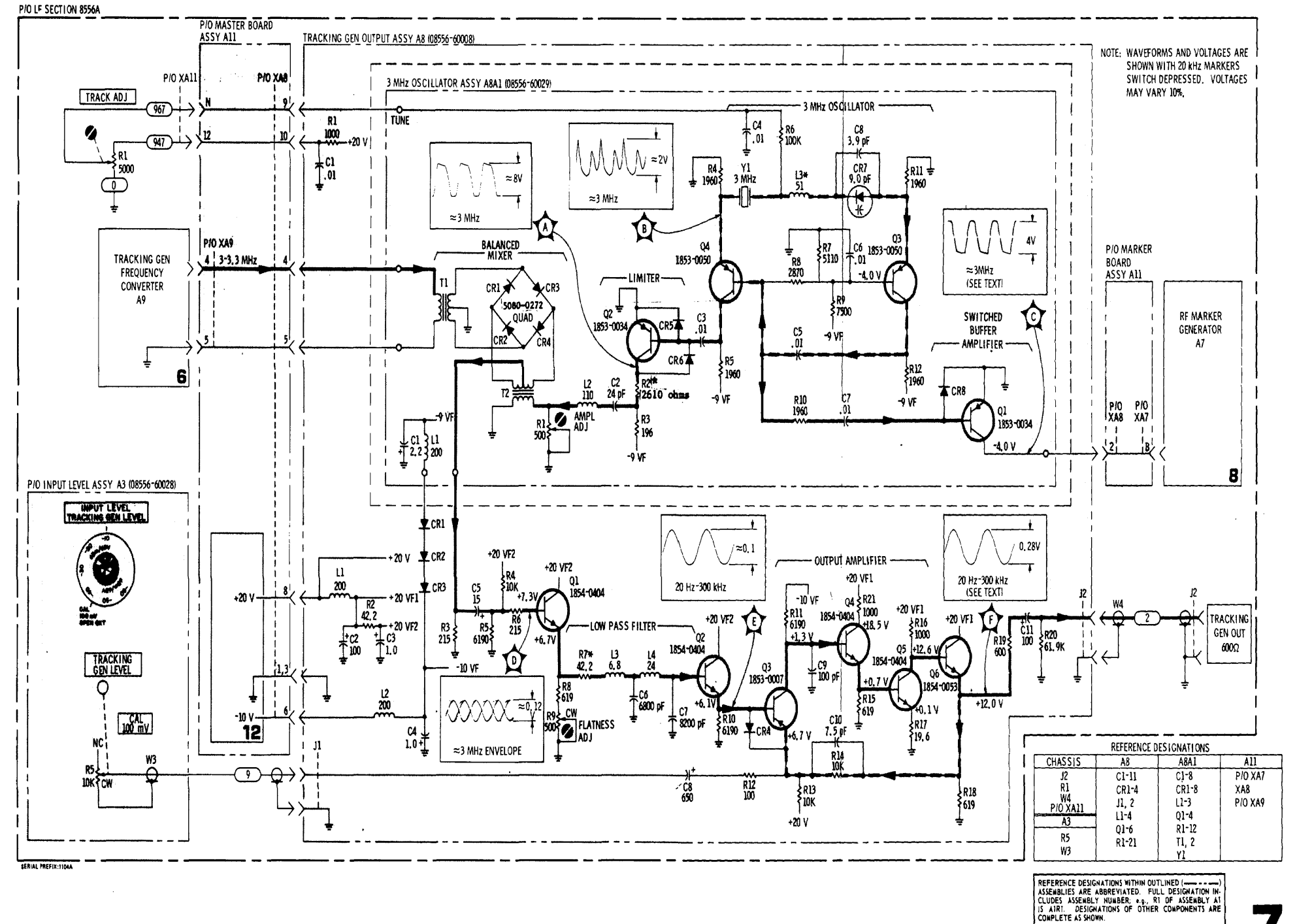

Figure 8-32. Tracking Generator Output: A3 and A8

SERVICE SHEET 8

THEORY OF OPERATION

General

The 20 kHz marker circuits apply markers to the input signal path when the 20 kHz MARKERS switch is depressed. A7Q1 turns on and applies -5 V to A7U1, U2, U3, U6 and U7. It also applies negative voltage through A7R1 to Q1 on the 3 MHz Oscillator Assembly A8A1 (see Service Sheet 7). A8A1 Q1 amplifies 3 MHz and feeds it to the 0 kHz marker circuits. The input 3 MHz sine wave is clipped by A7U7C and fed to the divide by 3 circuits.

Divide by 3 Circuits

A7U6 is dual JK master/slave flip-flop, and U6A and U6B form a Johnson, or shift, counter. The counter has four possible states: binary 0, 1, 2 and 3. In normal operation the counter cycles through binary counts 1, 2 and 3, changing from one to the other on the negative half cycle of each input pulse. If the counter ever cycled into binary 0 (both Q outputs low) it would not cycle itself out. U7B, connected to the Q outputs, clears flip-flop U6B if, and only if, the counter cycles into binary 0. The counter's output is decoded by NAND gate U7A, inverted by U7D, and fed to the divide by 50 circuit. The output at U7D is a 1 MHz pulse, 0.33 μ s wide.

Divide by 50 Circuit

A7U1, U2 and U3 form series, or ripple, counter circuits that divide the 1 MHz pulse by 50 without changing its 0.33 μ s pulse width. U1 divides the pulse by 10 and feeds it to U2 and to quad-input NAND gate U3. U2 divides the pulse by 2 and divides the input from U1 by 5 and sends both outputs to U3. When all four inputs of U3 are high, its output goes low. As shown in the timing diagram, this results in a 20 kHz pulse with a very narrow pulse width (0.33 μ s). The narrow pulse width insures that the 20 kHz markers will extend beyond 300 kHz without significant amplitude decreases.

TROUBLESHOOTING

Equipment:

Oscilloscope HP 180A/1801A/1820B
X10 Oscilloscope Probe (2) HP 10004A
Digital Voltmeter HP 3480B/3484A Option 043
Cable Assy HP 11002A
Extender Cable Assy HP 11592-60015
Extender Board HP 5060-0256

General

Normally trouble is isolated to the Frequency Control and Marker Generator Assembly A7 using the overall troubleshooting tree or the troubleshooting block diagram. Isolate trouble to the circuit level using the troubleshooting tree and procedures outlined below. The voltages listed on the schematics should assist in isolating trouble to a specific component.

Extend the LF and IF Sections on the extender cables; remove the A7 assembly from the chassis and re-install it on the extender board.

Service

Model 8556A

SERVICE SHEET 8 (cont'd)

Switched Power Supply

Push 20 kHz MARKERS switch and check voltages shown on schematic with a Digital Voltmeter. If voltages are incorrect, check A7Q1 and associated circuitry.

Divide By 3 Shift Counter

Push 20 kHz MARKERS switch and connect Oscilloscope (with X10 probes) to test points 1 and 2. Check pulse amplitudes and widths as shown on schematic. Check that pulse relationships approximate those shown in shift counter timing diagram. If checks indicate shift counter malfunction, check A7U6, U7 and associated circuitry.

Divide By 50 Counter

Push 20 kHz MARKERS switch and connect Oscilloscope (with X10 probes) to test points 2 and 3. Check pulse amplitudes and widths as shown on schematic. Check that pulse relationships approximate those shown in counter timing diagram. If checks indicate shift counter malfunction, check A7U1, U2, U3 and associated circuitry.

Troubleshooting Tree

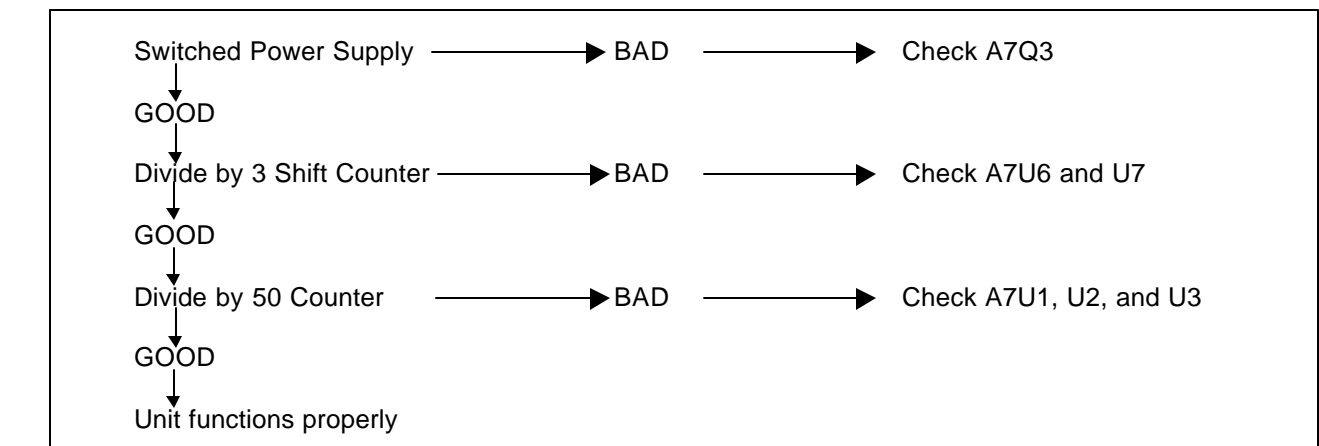

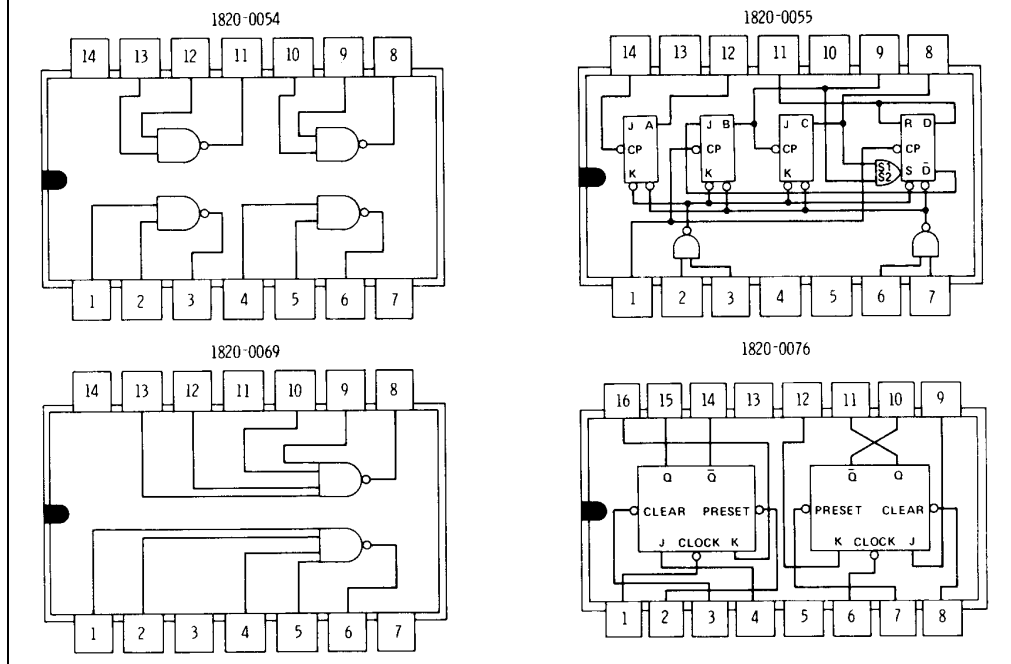

Figure 8-33. Integrated Circuit Logic Diagrams

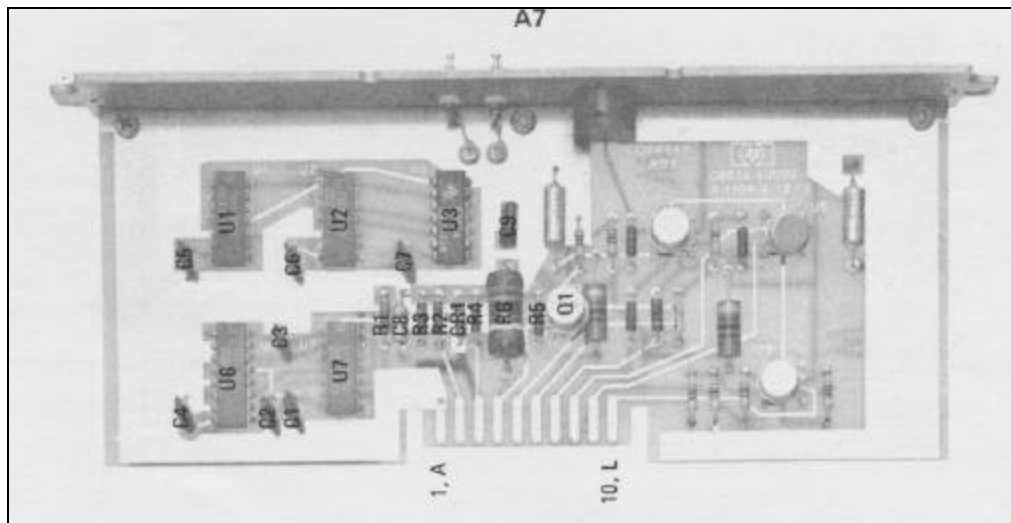

Figure 8-34. Frequency Control and Marker Generator Assy A7 Component Locations

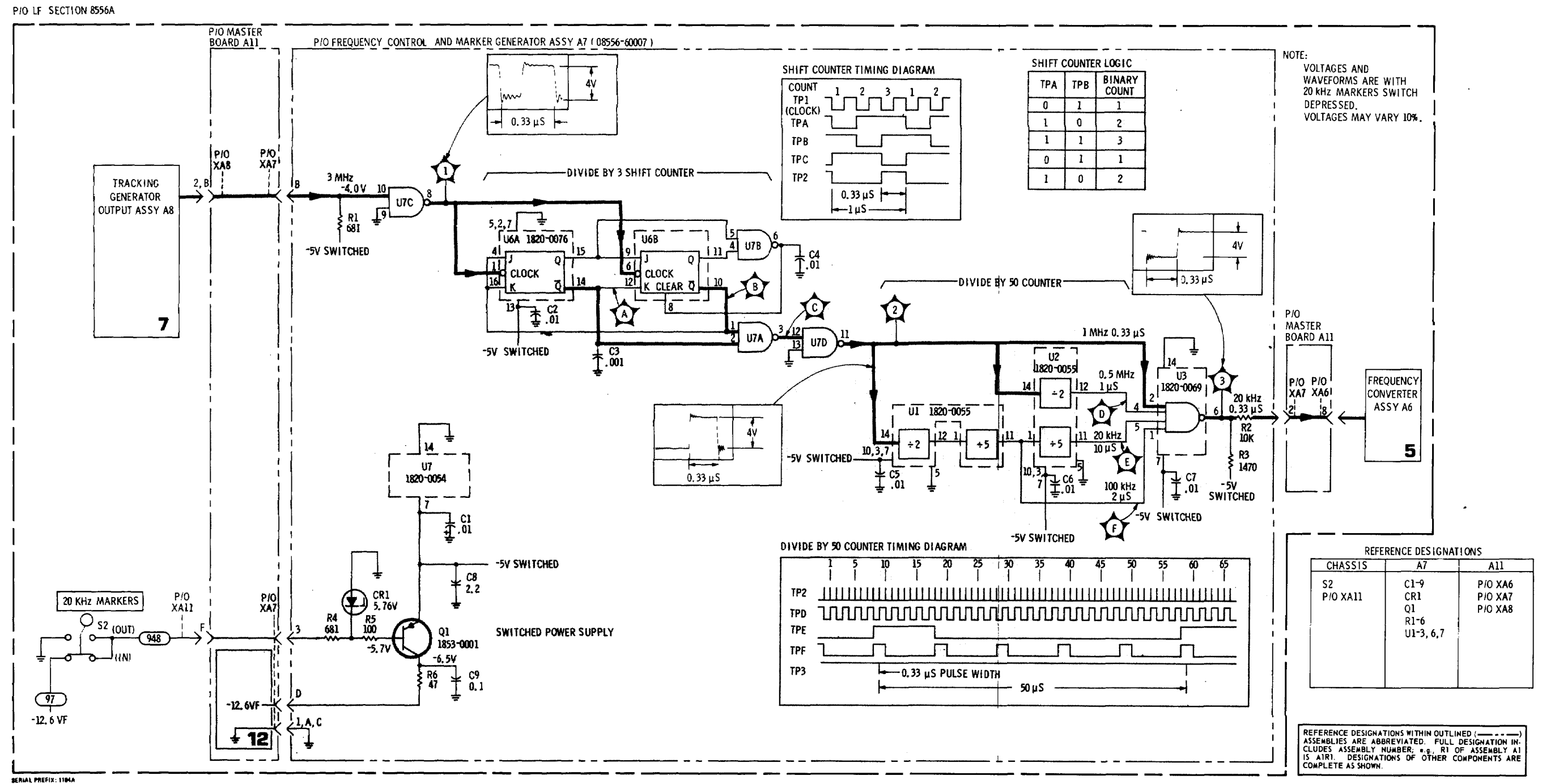

Figure 8-35. 20 KHz Marker Circuits: A7

SERVICE SHEET 9

THEORY OF OPERATION

General

The frequency control circuits provide control voltages to the 47 MHz LO in the IF Section. The three voltages are:

- a. Center frequency control - corresponds to dial frequency, set by FREQUENCY and FINE TUNE knobs.
- b. Ramp control - determines width of frequency scan, set by SCAN WIDTH knobs.
- c. Zero adjustment - compensates for drift in IF Section 47 MHz LO, set by ZERO ADJ knob.

Center Frequency Control Circuits

The output of tune amplifier A7U4 can be set from 0 to +15 V by the FREQUENCY and FINE TUNE knobs; this corresponds to dial settings of 0 to 300 kHz. 300 kHz ADJ R5 sets dial accuracy at 300 kHz. OFFSET ADJ A7R13 is used to set the amplifier's output to 0 V when the dial is at 0 Hz.

When RANGE kHz switch S3 is set to 0-30, it adds a voltage divider to the output of A7U4. This divider divides A7U4's output by 10; a 0 to 1.5 V swing corresponds to dial settings of 0 to 30 kHz.

When SCAN WIDTH is set to ZERO and PER DIVISION, A7U4's output is fed to A7U5 and on to the IF Section 47 MHz LO control circuits. When SCAN WIDTH is set to 0-10f the voltage sent to the IF Section through A7U5 is determined by PER DIVISION switch S1-4F (more about A7U5 below).

Ramp Control Circuits

When SCAN WIDTH is set to ZERO, the ramp from the IF Section scan circuits is disabled by S2-IF, and scan-offset amplifier output is 0 V. This prevents the IF Section 47 MHz LO from being swept (however, its frequency is still set by the center frequency control circuits).

When SCAN WIDTH is set to PER DIVISION or 0-10f, the -5 V to +5 V ramp from the IF Section scan circuits is fed to scan-offset amplifier A7U8. In PER DIVISION the scan-offset amplifier has unity gain so its output is a -5 V to +5 V ramp. This ramp is fed to the scan width attenuator and on to the IF Section 47 MHz LO control circuits. The amplitude of the ramp determines the frequency range over which the 47 MHz LO is swept.

When SCAN WIDTH is set to 0-10f and PER DIVISION is set to 10 kHz or less, A7U8 is offset 5 V. This offsets the ramp so that it sweeps from 0 to +10 V. The 0 to +10 V ramp is then sent through the scan width attenuator to the IF Section. The offset ramp will sweep the 47 MHz LO from 0 Hz to a frequency determined by the ramp's amplitude. To prevent control of the 47 MHz LO by the frequency control circuits the input to the voltage follower amplifier A7U5 is referenced to 0 V.

When SCAN WIDTH is set to 0-10f and PER DIVISION is set to 20 kHz, the offset is applied to voltage follower amplifier A7U5. Scan-offset amplifier A7U8 is not offset and its output is a -5 V to +5 V ramp. In all other respects operation is as described when PER DIVISION is set to 10 kHz or less.

SERVICE SHEET 9 (cont'd)

Zero Adjustment Circuit

ZERO ADJ pot R6 is in a divider network from +20 V to ground. It can change the 47 MHz LO in the HP 8552B about 24 kHz, and in the HP 8552A about 54 kHz. When the LF Section is connected to an HP 8552B, P3 pin 15 is connected to +20 V; P3 pin 15 is open when connected to an HP 8552A. This compensates for operating differences between the IF Sections.

TROUBLESHOOTING

Equipment:

- Oscilloscope HP 180A/1801A/1820B
- X10 Oscilloscope Probe HP 10004A
- Digital Voltmeter HP 3480B/3484A Option 042
- Cable Assy HP 1102A
- Extender Cable Assy HP 11592-60015
- Extender Board HP 5060-0256

General

Normally trouble is isolated to the Frequency Control and Marker Generator Assembly A6 using the overall troubleshooting tree or the troubleshooting block diagram. Isolate trouble to the circuit level using the troubleshooting tree and procedures outlined below.

Extend the LF and IF Sections on the extender cables; remove the A7 assembly from the chassis and re-install it on the extender board.

Center Frequency Control Circuits

Connect Digital Voltmeter to test point A (A11XA7 pin 5) and set analyzer controls as follows:

- FREQUENCY0 kHz (set accurately)
- FINE TUNE Centered
- BANDWIDTH..... 100 Hz
- SCAN WIDTH PER DIVISION
- PER DIVISION 10 kHz
- RANGE0-300 kHz

The voltmeter should read 0.0 ±5.0 mVdc. If not, adjust OFFSET ADJ (A7R13) until it does.

Tune FINE TUNE from full clockwise to full counter-clockwise; the voltage at test point A should swing about 50 ± 5 mVdc. Re-center FINE TUNE.

Set FREQUENCY to 300 kHz. Tune 300 kHz ADJ (on front panel) from full clockwise to full counter-clockwise; the voltage at test point A should swing from 15.50 to 15.85 Vdc.

Adjust 300 kHz ADJ until voltage at test point a is +15.40 V. (Factory select value A1R1 sets 300 kHz ADJ range, see Table 8-1.) Switch RANGE to 0-30 kHz; the voltage should be +1.540 ±0.008 V.

Set RANGE to 0-300 kHz and connect voltmeter to test point B (A11XA7 pin 8); the voltage should be +15.40 ±.01 V. Set SCAN WIDTH to 0-10f; the voltage should decrease to 0.0 ±.01 V. Set PER DIVISION to 20 kHz; the voltage should be +5.00 ±0.05 V.

SERVICE SHEET 9 (cont'd)

If checks indicate center frequency control circuit malfunction, check A7U4, U5 and associated circuitry.

After repairing center frequency control circuits, perform frequency calibration adjustment procedure specified in paragraph 5-28.

NOTE

After replacing the frequency tuning pot R3, perform the dial calibration procedure in paragraph 8-70.

Ramp Control Circuits

Connect Digital Voltmeter to test point C (A11XA7 pin L) and set analyzer controls as follows:

- SCAN WIDTH PER DIVISION
- PER DIVISION 20 kHz
- SCAN TIME PER DIVISION 5 MILLISECONDS
- SCAN MODESINGLE
- SCAN TRIGGERAUTO

The voltage at test point C should be -5.00 ±0.01 V. Set SCAN MODE to INT and connect Oscilloscope (with X10 probe) to test point C; the signal should be 10 V p-p sawtooth as shown on schematic. If checks described above are bad, check scan generator circuits in IF Section.

Set SCAN WIDTH to 0-10f, Scan MODE to SINGLE and connect voltmeter to test point D (A11XA7 pin 10). The voltmeter should read -5.00±0.01 V. Set PER DIVISION to 10 kHz; the voltmeter should read 0.0 ±.01 Vdc.

Set SCAN WIDTH to PER DIVISION, PER DIVISION to 20 kHz and connect voltmeter to test point E (934 wire at A2S1 lug 12). The voltmeter should read as indicated for the following scan widths:

PER DIVISION	Voltmeter reading
20 kHz	-5.000 ±0.050 V
10 kHz	-2.500 ±0.025 V
5 kHz	-1.250 ±0.013 V
2 kHz	-500.0 ±5.0 mV
1 kHz	-250.0 ±2.5 mV
500 Hz	-125.0 ±1.3 mV
200 Hz	-50.00 ±0.50 mV
100 Hz	-25.00 ±0.25 mV
50 Hz	-12.50 ±0.14 mV
20 Hz	-5.00 ±0.07 mV

If checks indicate ramp control circuit malfunction, check A7U8, scan width attenuator and associated circuits. After repairing ramp control circuits, perform frequency calibration adjustment procedure specified in paragraph 5-28.

Service

Model 8556A

SERVICE SHEET 9 (cont'd)

Zero Adjustment Circuit

Set analyzer as follows:

- FREQUENCY 0 kHz
- FINE TUNE Centered
- BANDWIDTH 3 kHz
- SCAN WIDTH PER DIVISION
- PER DIVISION 10 kHz
- INPUT LEVEL-10 dBm/dBV
- BASE LINE CLIPPER.....ccw
- VIDEO FILTER OFF
- SCAN TIME PER DIVISION 5 MILLISECONDS
- LOG/LINEAR..... 10 dB LOG
- LOG REF LEVEL-10 dBm/dBV
- SCAN MODEINT
- SCAN TRIGGERAUTO

Tune ZERO ADJ (on front panel) from full counter-clockwise to full clockwise. The LO feed through signal on the CRT should shift as follows:

- a. with 8552A IF Section, 54 ±2 kHz
- b. with 8552B IF Section, 24 ± 2 kHz

If not, check R6, ZERO ADJ pot and associated circuitry. After repairing zero adjustment circuit, perform frequency calibration adjustment procedure specified in paragraph 5-28.

Troubleshooting Tree

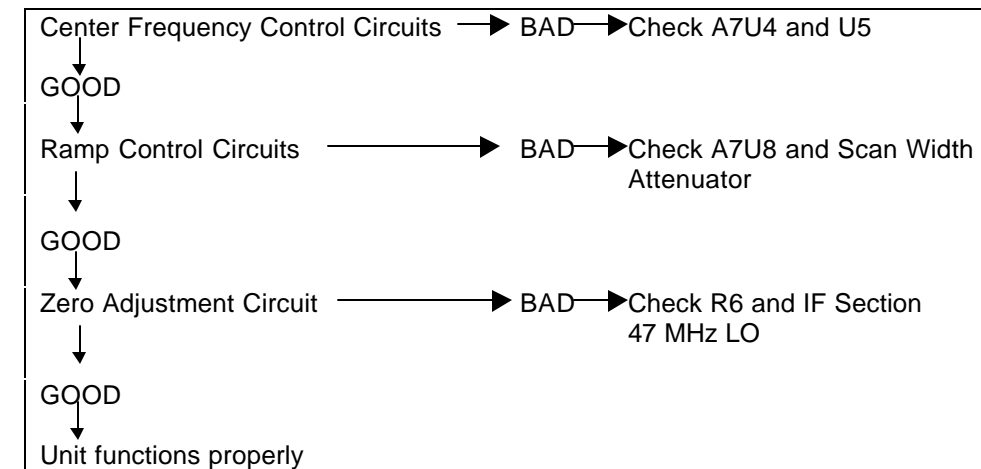

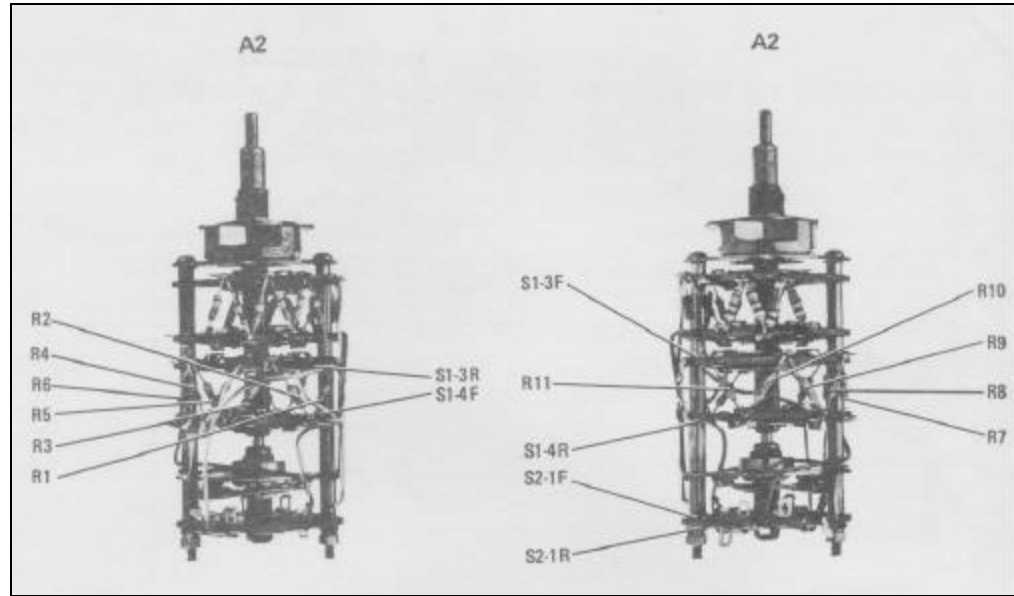

Figure 8-36. Scan Width Switch Assembly A2 Component Locations

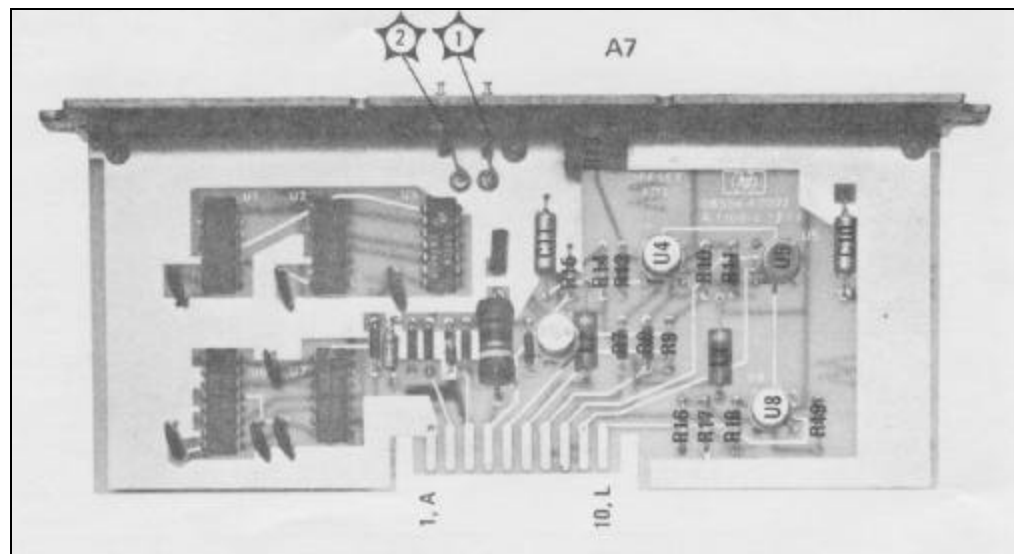

Figure 8-37. Frequency Control and Marker Generator Assy A7 Component Locations

SERVICE SHEET 9

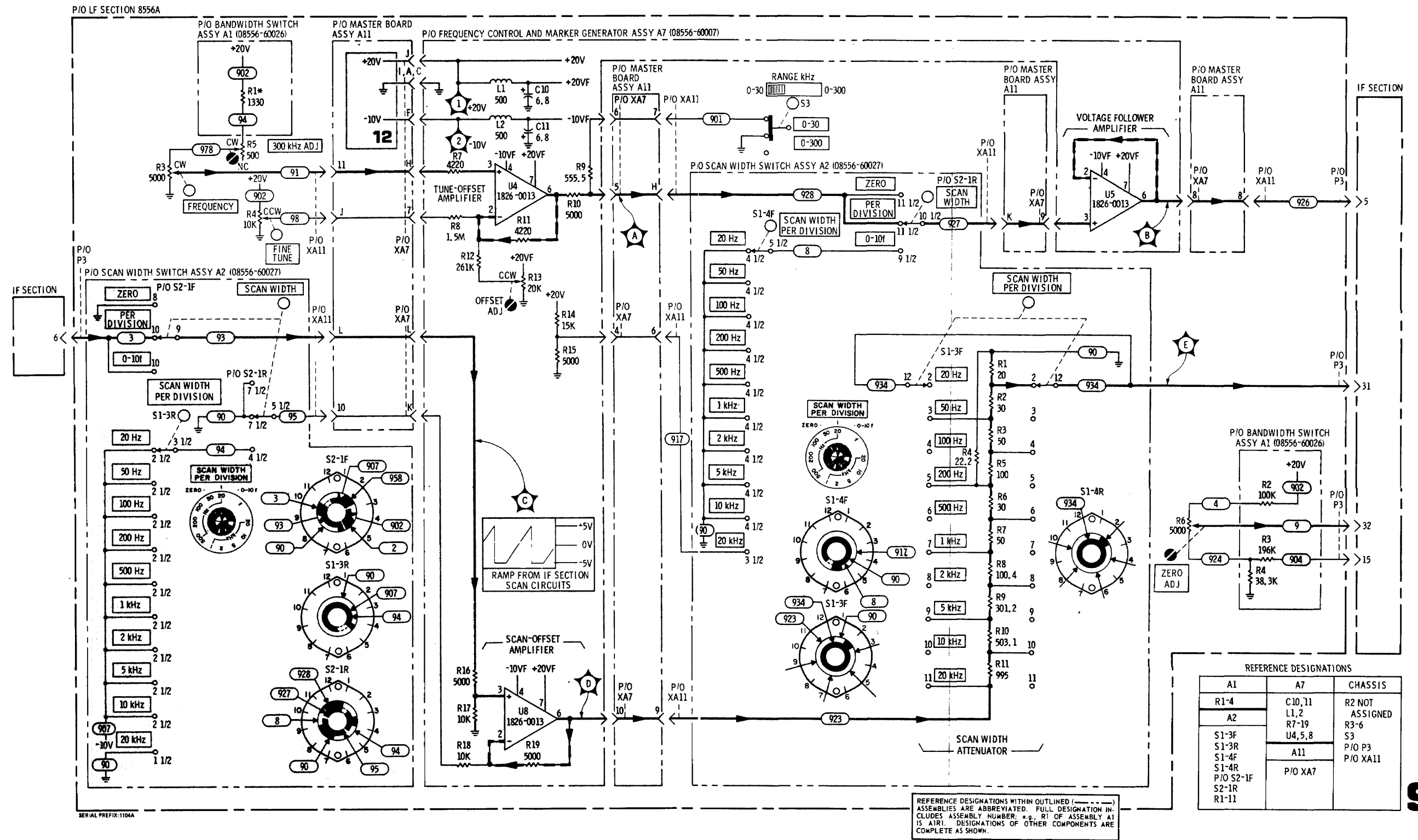

Figure 8-38. Frequency Control Circuits: A1, A2 and A7

SERVICE SHEET 10

THEORY OF OPERATION

The DISPLAY UNCAL lamp DS1 illuminates when SCAN WIDTH PER DIVISION, BANDWIDTH, SCAN TIME and VIDEO FILTER are set at any combination of positions which does not permit accurate calibration of the analyzer (see Figure 8-39). The DISPLAY UNCAL lamp is illuminated by a simulated signal and has no actual connection to signal processing circuits.

The LF Section Scan Width Switch Assembly A2 and Bandwidth Switch Assembly A1 both have switch wafers devoted exclusively to analogic. (In the IF Section the Scan Time Switch Assembly and Video Filter Switch also have analogic wafers.) When SCAN WIDTH is set to PER DIVISION or 0-10f, current is added to the two buss lines (956 and 957 wires) by BANDWIDTH and PER DIVISION. In the IF Section this current is summed with the current added by SCAN TIME and VIDEO FILTER. When the current on either buss line is high enough to bias the light driver in the IF Section into conduction, it turns on and lights the DISPLAY UNCAL lamp (see Service Sheet 12). When SCAN WIDTH is set to ZERO, the analogic circuit is disabled.

TROUBLESHOOTING

Equipment:

Digital Voltmeter HP 3480B/3484A Option 042
 Cable Assy HP 11002A

General

When trouble has been isolated to the LF Section analogic, perform the following checks;

Remove the LF and IF Sections from the Display Section and disconnect the LF Section from the IF Section. Remove the top and bottom covers from the LF Section.

Unsolder the 2 white-green-blue (956) wires from lug 5½ of S1-1R and the 2 white-green-violet (957) wires from lug 6 of S1-1F of Bandwidth Switch Assembly A1.

Bandwidth Switch Resistance Measurement

With 956 and 957 wires removed, and LF Section disconnected from IF Section and Display Section, measure resistance from lug 5½ of S1-1R (where 956 wire was connected) to lug 7 of S1-2F (where 958 wire is connected). Also, measure resistance from lug 6½ of S1-1F (where 957 wire was connected) to lug 7 of S1-2F.

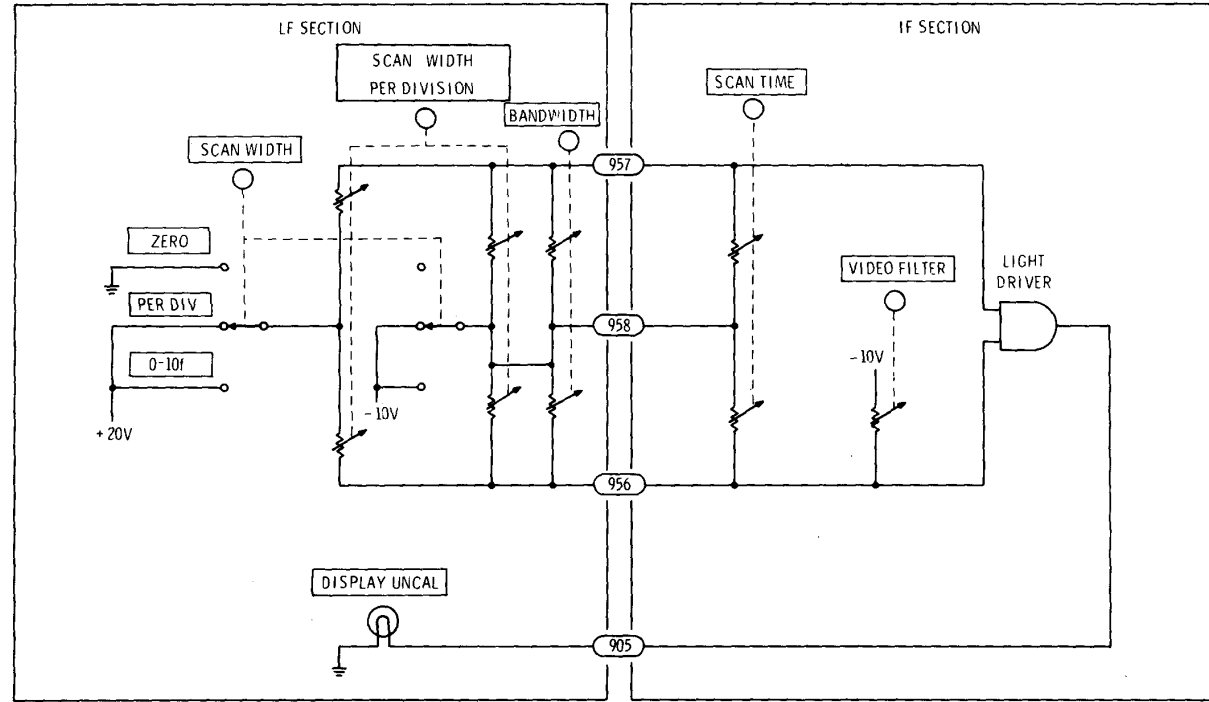

Figure 8-39. Simplified Analogic Diagram

Service

Model 8556A

SERVICE SHEET 10 (cont'd)

Resistance should be within 2% of values tabulated below for each BANDWIDTH position.

BANDWIDTH	Resistance (kΩ) ± 2%	
	S1-R, lug 5% to S1-2F, lug 7	S1-1F, lug 6 to S1-2F, lug 7
10 kHz	48.33	31.22
3 kHz	43.25	26.13
1 kHz	39.85	22.73
300 Hz	37.35	20.28
100 Hz	35.54	18.46
30 Hz	34.13	17.04
10 Hz	44.78	14.04

Scan Width Switch Resistance Measurement

With 956 and 957 wires removed from Bandwidth Switch Assembly A1, and LF Section disconnected from IF Section and Display Section, measure resistance from Scan Width Switch Assembly A2 lug 6 of S1-2F (where 956 wire is connected) to lug 2 of S2-1F (where 958 wire is connected). Also, measure resistance from lug 5 of S1-2R (where 957 wire is connected) to lug 2 of S2-1F.

Resistance should be within 2% of values tabulated below for each SCAN WIDTH PER DIVISION position.

SCAN WIDTH PER DIVISION	Resistance (kΩ) ± 2% For Both Measurements
20 kHz	61.78
10 kHz	67.24
5 kHz	74.88
2 kHz	86.30
1 kHz	106.1
500 Hz	144.8
200 Hz	260.8
100 Hz (and below)	open (OVER RANGE)

Measure resistance from lug 6 of S1-2F (where 956 wire is connected) to lug 5 of S2-1F (where 2 wire is connected). Also, measure resistance from lug 5 of S1-2R (where 957 wire is connected) to lug 5 of S2-1F.

Resistance should be within 2% of values tabulated below for each SCAN WIDTH PER DIVISION position.

SCAN WIDTH PER DIVISION	Resistance (kΩ) ± 2% For Both Measurements
100 Hz (and above)	open (OVER RANGE)
50 Hz	483.3
20 Hz	256.0

Make any necessary repairs, re-solder 956 and 957 wires to Bandwidth Switch Assembly A1, and perform analogic checks as specified in paragraph 5-29.

SERVICE SHEET 11

THEORY OF OPERATION

The AMPL CAL pot controls a calibration amplifier in the IF Section. The calibration amplifier is used to calibrate the analyzer's absolute amplitude. See the 3 MHz IF Amplifier circuit description in the IF Section manual.

Input Level Switch

Two wafers of the Input Level Switch Assembly A3 control circuits in the IF Section. S1-2R lights index lamps on the LOG REF LEVEL switch. S1-3R is part of the linear gain compensation network; see the Log/Linear Amplifier circuit description in the IF Section manual.

Bandwidth Switch

The portion of the Bandwidth Switch Assembly shown provides positive or negative voltages that select and bypass bandwidth circuits in the IF Section. See the bandwidth circuit descriptions in the IF Section manual.

TROUBLE SHOOTING

Equipment:

Digital Voltmeter	HP 3480B/3484A Option 042
Cable Assy	HP 11002A
Extender Cable Assy	HP 11592 60015
Interconnection Cable Assy H.....	HP 11592-60016

Normally trouble is isolated to the IF Section control circuits after troubleshooting the IF Section. Isolate trouble to a specific component using the Digital Voltmeter to check the voltages and resistances shown on the schematic.

Extend the LF and IF Sections on the extender cables; separate the LF Section from the IF Section and install the interconnection cable. Check and, if necessary, repair the components and assemblies shown.

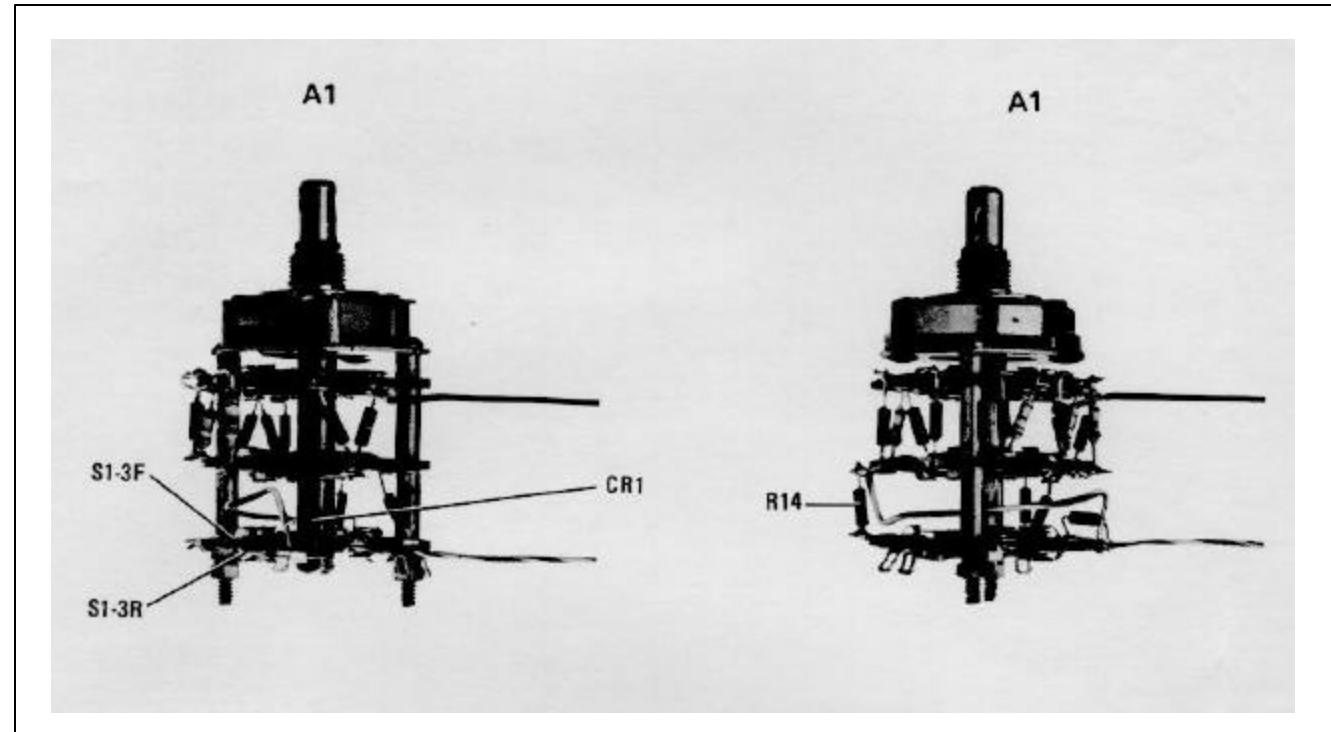

Figure 8-43. Bandwidth Switch Assembly A1 Component Locations

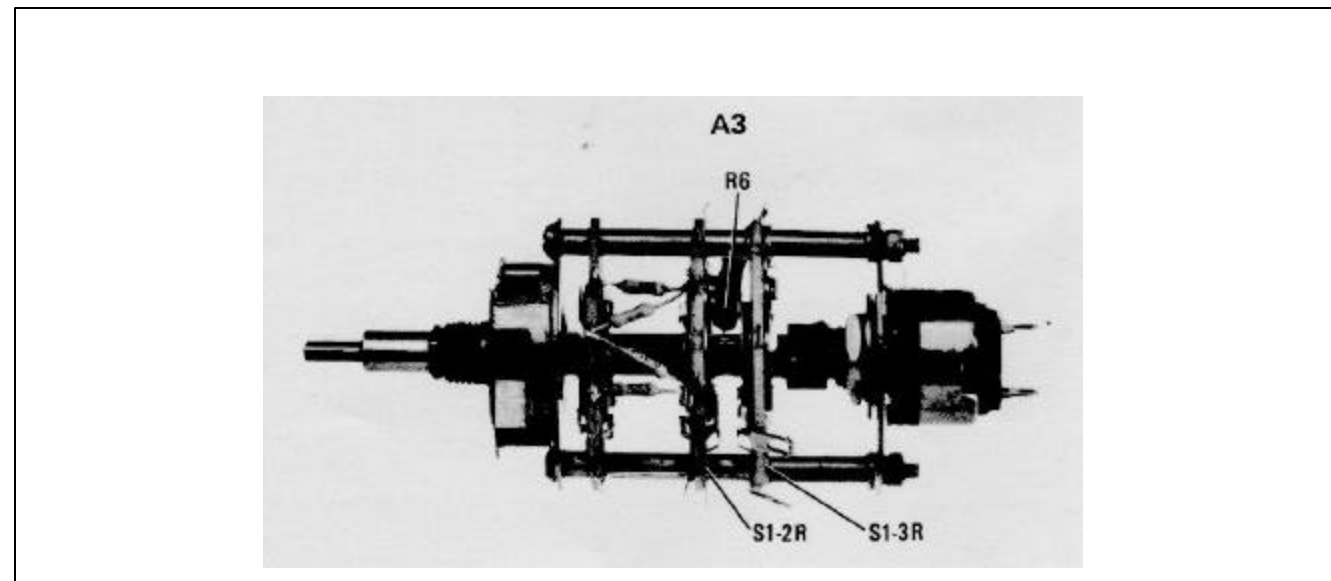

Figure 8-44. Input Level Switch Assembly A3 Component Locations

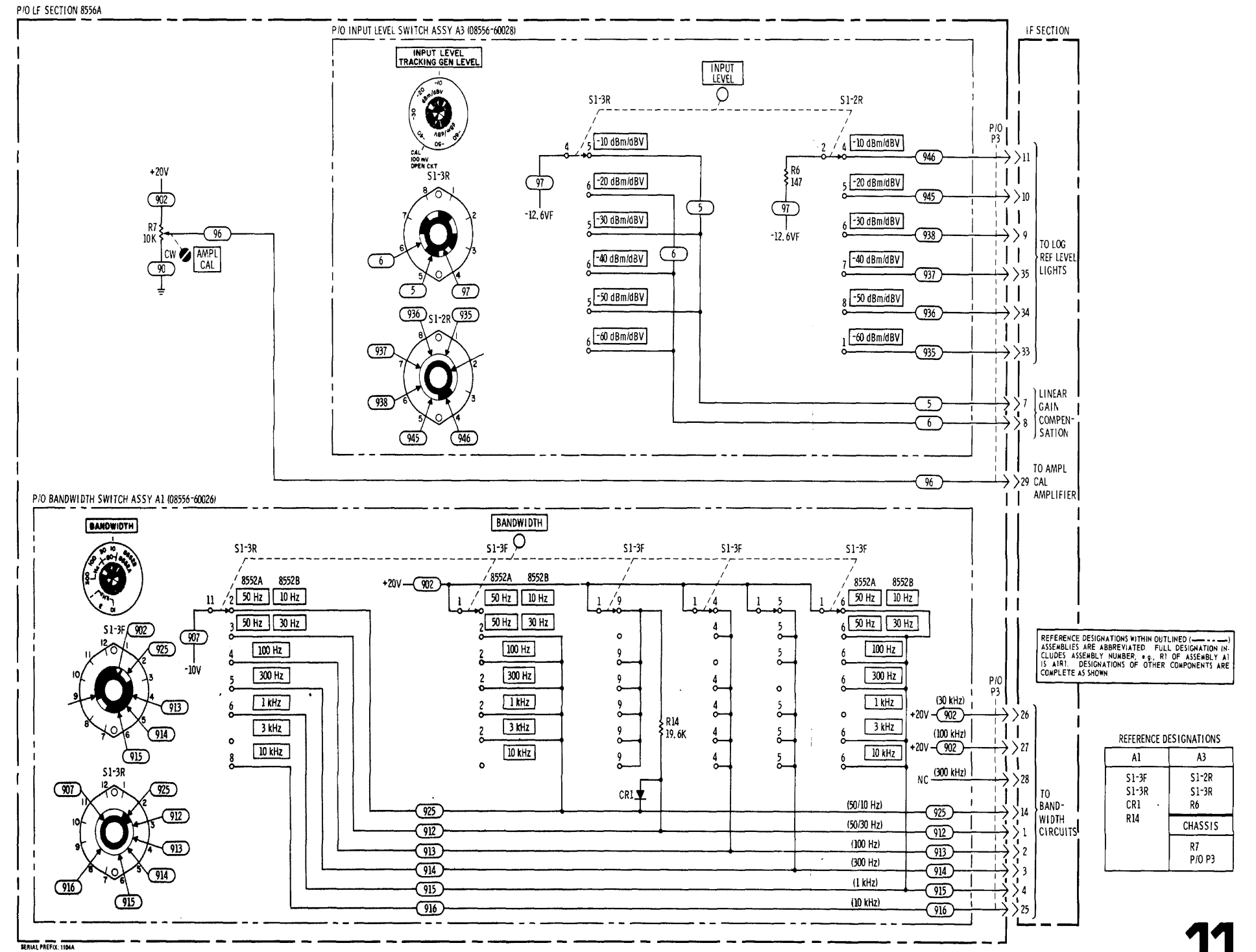

Figure 8-45. IF Section Control Circuits: A1 and A3

SERVICE SHEET 12

THEORY OF OPERATION

General

The sources for the supply voltages used in the LF Section are shown.

Isolated Power Supply

The Pre-Attenuator and Preamplifier Assembly A5 (see Service Sheet 4) is isolated from chassis ground. The Power Supply Assembly A10 provides isolated supply voltages for the preamplifier and an isolated ground for all of the input circuitry. This prevents line related signals being introduced into the input signal path.

A10Q1 and Q2 saturate, in turn, and send current ramps through the primary windings of A10T1. The switching rate of Q1 and Q2 is about 500 kHz. The current ramps induce a voltage in the secondary of T1. The voltage is rectified by the bridge rectifier, filtered and sent to the master board. On the master board the voltages are again filtered and fed to the preamplifier. A11R6 is a bleeder resistor that prevents static charges from building up in the isolated circuits.

TROUBLE SHOOTING

Equipment:

Oscilloscope	HP 180A/1801A/1820B
X10 Oscilloscope Probe	HP 10004A
Digital Voltmeter	HP 3480B/3484A Option 042
Cable Assy	HP 11002A
Extender Cable Assy	HP 11592-60015
Interconnection Cable Assy	HP 11592-60016
Extender Board	HP 5060-0256

General

Normally trouble is isolated to the Power Supply Assembly A10 and the voltage distribution circuits using the overall troubleshooting tree or the troubleshooting block diagram. Isolate trouble to a specific circuit using the procedures outlined below. The voltages listed on the schematic should assist in isolating trouble to a specific component.

Extend the LF and IF Sections on the extender cables; separate the LF Section from the IF Section and install the interconnection cable. Remove the A10 assembly from the chassis and re-install it on the extender board.

Isolation

Remove Pre-Attenuator and Preamplifier Assembly A5 from chassis. Connect Digital Voltmeter from A5 assembly cover to chassis ground and measure resistance. It should be about 100 k ohms. If not, remove A10 assembly from chassis and re-check. If resistance is about 100 k ohms with A10 removed, check A10T1, bridge rectifier, and filter on A10 assembly. If resistance is less than 100 k ohms with A10 removed, check filter circuits on Master Board Assembly All (some of these circuits are shown on Service Sheet 4).

Isolated Power Supply

Connect Oscilloscope (with X10 probe) to test point 1. Waveform should be as shown on schematic: 400 to 600 kHz, 25 to 30 V p-p. If not, check 400-600 kHz oscillator (A10Q1, Q2 and associated circuitry).

Connect Digital Voltmeter across +20 VI and -20 VI test points on Pre-Attenuator and Preamplifier Assembly A5. The voltage should be 40 ±4 V dc. If not, check bridge rectifier and filter circuits.

Power Supply and Voltage Distribution

SERVICE SHEET 12 ➡

APPENDIX A

REFERENCES

DA Pam 310-1	Consolidated Index of Army Publications and Blank Forms.
TM 11-6625-2781-14&P	Spectrum Analyzer IP-1216(P)/GR (Hewlett-Packard model 141T).
TM 11-6625-2781-14-1	Spectrum Analyzer IF Section Plug-In Unit PL-1388,U (Hewlett-Packard model 8552B).
TM 38-750	The Army Maintenance Management system (TAMMS).
TM 750-244-2	Procedures for Destruction of Electronics Materiel to Prevent Enemy Use (Electronics Command).

APPENDIX B MAINTENANCE ALLOCATION

Section I. INTRODUCTION

B-1. General

This appendix provides a summary of the maintenance operations for the PL-1387/U low frequency plug-in. It authorizes categories of maintenance for specific maintenance functions on repairable items and components, and the tools and equipment required to perform each function. This appendix may be used as an aid in planning maintenance operations.

B-2. Maintenance Function

Maintenance functions will be limited to and defined as follows:

a. Inspect. To determine the serviceability of an item by comparing its physical, mechanical, and/or electrical characteristics with established standards through examination.

b. Test. To verify serviceability and to detect incipient failure by measuring the mechanical or electrical characteristics of an item and comparing those characteristics with prescribed standards.

c. Service. Operations required periodically to keep an item in proper operating condition; i.e., to clean (decontaminate), to preserve, to drain, to paint, or to replenish fuel, lubricants, hydraulic fluids, or compressed air supplies.

d. Adjust. To maintain, within prescribed limits, by bringing into proper or exact position, or by setting the operating characteristics to the specified parameters.

e. Align. To adjust specified variable elements of an item to bring about optimum or desired performance.

f. Calibrate. To determine and cause corrections to be made or to be adjusted on instruments or test measuring and diagnostic equipments used in precision measurement. Consists of comparisons of two instruments, one of which is a certified standard of known accuracy, to detect and adjust any discrepancy in the accuracy of the instrument being compared.

g. Install. The act of emplacing, seating, or fixing into position an item, part, module (component or assembly) in a manner to allow the proper functioning of the equipment or system.

h. Replace. The act of substituting a serviceable like type part, subassembly, or module (component or assembly) for an unserviceable counterpart.

i. Repair. The application of maintenance services (inspect, test, service, adjust, align, calibrate, replace) or other maintenance actions (welding, grinding,

riveting, straightening, facing, remachining, or resurfacing) to restore serviceability to an item by correcting specific damage, fault, malfunction, or failure in a part, subassembly, module (component or assembly), end item or system.

j. Overhaul. That maintenance effort (service action) necessary to restore an item to a completely serviceable operational condition as prescribed by maintenance standards (i.e., DMWR) in appropriate technical publications. Overhaul is normally the highest degree of maintenance performed by the Army. Overhaul does not normally return an item to like new condition.

k. Rebuild. Consists of those services/actions necessary for the restoration of unserviceable equipment to a like new condition in accordance with original manufacturing standards. Rebuild is the highest degree of materiel maintenance supplied to Army equipment. The rebuild operation includes the act of returning to zero those age measurements (hours, miles, etc.) considered in classifying Army equipments components.

B-3. Column Entries. (Section II)

a. Column 1. Group Number. Column 1 lists group numbers, the purpose of which is to identify components, assemblies, subassemblies and modules with the next higher assembly.

b. Column 2, Component/Assembly. Column 2 contains the noun names components, assemblies, subassemblies and modules for which maintenance is authorized.

c. Column 3. Maintenance Functions. Column 3 lists the functions to be performed on the item listed in column 2. When items are listed without maintenance functions, it is solely for the purpose of having the group numbers in the MAC and RPSTL coincide.

d. Column 4, Maintenance Category. Column 4 specifies, by the listing of a "work time" figure in the appropriate subcolumn(s), the lowest level of maintenance authorized to perform the function listed in column 3. This figure represents the active time required to perform that maintenance function at the indicated category of maintenance. If the number or complexity of the tasks within the listed maintenance function vary at different maintenance categories, appropriate "work time" figures will be shown for each category.

The number of task-hours specified by the "work time" figure represents the average time required to restore an item (assembly, subassembly, component, module, end item or system) to a serviceable condition under typical field operating conditions. This time includes preparation time, troubleshooting time, and quality assurance/quality control time in addition to the time required to perform the specific tasks identified for the maintenance functions authorized in the maintenance allocation chart. Subcolumns of column 4 are as follows:

- C-Operator/Crew
- O-Organizational
- F-Direct Support
- H-General Support
- D-Depot

e. Column 5, Tools and Equipment. Column 5 specifies by code those common tool sets (not individual tools) and special tools, test, and support equipment required to perform the designated function.

f. Column 6, Remarks. Column 6 contains an alphabetic code which leads to the remark in Section V, Remarks, which is pertinent to the item opposite the particular code.

B-4. Tool and Test Equipment Requirements (Section III)

a. Tool or Test Equipment Reference Code. The numbers in this column coincide with the numbers used in the tools and equipment column of the MAC. The numbers indicate the applicable tool or test equipment for the maintenance functions.

b. Maintenance Category. The codes in this column indicate the maintenance category allocated the tool or test equipment.

c. Nomenclature. This column lists the noun name and nomenclature of the tools and test equipment required to perform the maintenance functions.

d. National/NATO Stock Number. This column lists the National/NATO stock number of the specific tool or test equipment.

e. Tool Number. This column lists the manufacturer's part number of the tool followed by the Federal Supply Code for manufacturer's (5-digit), in parentheses.

B-5. Remarks (Section IV)

a. Reference Code. This code refers to the appropriate item in Section II, column 6.

b. Remarks. This column provides the required explanatory information necessary to clarify items appearing in Section II.

**Section II. MAINTENANCE ALLOCATION CHART
FOR
SPECTRUM ANALYZER LOW-FREQUENCY PLUG-IN PL-1387/U**

(1) GROUP NUMBER	(2) COMPONENT ASSEMBLY	(3) MAINTENANCE FUNCTION	(4) MAINTENANCE CATEGORY					(5) TOOLS AND EQPT.	(6) REMARKS
			C	O	F	H	D		
00	Spectrum Analyzer Low Frequency Plug-in PL-1387/U.	Inspect	0.5					11	N/A
		Test				0.5		1-10	N/A
		Service				0.7		1-10	N/A
		Install	0-3					11	N/A
		Replace	0-3					11	N/A
		Repair					1.3		1-10
		Calibrate				1.0			N/A

**Section III. TOOL AND TEST EQUIPMENT REQUIREMENTS
FOR
SPECTRUM ANALYZER LOW FREQUENCY PLUG IN PL-1387/U**

TOOL OR TEST EQUIPMENT REF CODE	MAINTENANCE CATEGORY	NOMENCLATURE	NATIONAL/NATO STOCK NUMBER	TOOL NUMBER
1	H, D	A.C. Voltmeter ME-459/U	6625-00-229-0457	N/A
2	H, D	Oscilloscope AN/USM-281A	6625-00-228-2201	“
3	H, D	Oscilloscope X10 Probe MX-8385/U	6625-00-132-3319	“
4	H, D	Frequency Counter AN/USM-207A	6625-00-044-3228	“
5	H, D	Voltmeter, Electronic ME-202()/U	6625-00-709-0288	“
6	H, D	L-C Meter AN/USM-357	6625-00-713-9077	“
7	H, D	Generator, Signal SG-970/U	6625-00-145-1193	“
8	H, D	Oscillator SG-299B/U	6625-00-808-5584	“
9	H, D	Transistor Test Set TS-1836C/U	6625-00-159-2263	“
10	H, D	Multimeter ME-26D/U	6625-00-913-9781	“
11	0	Tools and test equipment used by the repairperson for his/her assigned mission		

APPENDIX F

PART NUMBER-NATIONAL STOCK NUMBER CROSS REFERENCE INDEX

This appendix provides a commercial part number to National Stock Number (NSN) cross-reference. To obtain parts for which NSN's are not shown submit exception requisitions, giving commercial part numbers, to: Commander, US Army Communications and Electronics Command, ATTN; DRSEL-MM, Fort Monmouth, NJ 07703.

**PART NUMBER - NATIONAL STOCK NUMBER
CROSS REFERENCE INDEX**

PART NUMBER	FSCM	NATIONAL STOCK NUMBER	PART NUMBER	FSCM	NATIONAL STOCK NUMBER
BB-1011	01121	5905-00-180-8301	0698-3158	28480	5905-00-858-8927
B46-2	71041	3120-00-287-9026	0698-3161	28480	5905-00-974-6082
CB 1555	01121	5905-00-111-1684	0698-3162	28480	5905-00-840-8162
CM8-1099	71744	6240-00-103-0058	0698-3236	28480	5905-00-478-7462
CT-106-4	75042	5905-00-229-1972	0698-3260	28480	5905-00-998-1809
DDM-43W2-P	71468	5935-00-402-1519	0698-3271	28480	5905-00-407-0054
02361	93332	5961-00-954-9182	0698-3334	28480	5905-00-407-2350
FDG1088	07263	5961-00-928-7939	0698-3429	28480	5905-00-407-0075
G-126	79727	5930-00-919-1755	0698-3431	28480	5905-00-402-7079
NO. 1460	73734	5310-00-513-2495	0698-3440	28480	5905-00-828-0377
RDM15F101J3C	72136	5910-00-463-5949	0698-3441	28480	5905-00-974-6076
R2807-2	15636	5945-01-021-1739	0698-3443	28480	5905-00-194-0341
SN4342	01295	5962-00-138-5248	0698-3444	28480	5905-00-974-6079
SN4355	01295	5962-00-420-1677	0698-3451	28480	5905-00-405-3677
SN4356	01295	5962-00-493-5961	0698-3453	28480	5905-00-078-1548
SSM-.001-98	12574	5910-00-852-2661	0698-3454	28480	5905-00-974-6077
TXBF-032-025B	98978	5999-00-789-3794	0698-3455	28480	5905-00-407-0060
0121-0105	28480	5910-00-761-1216	0698-4037	28480	5905-00-232-3122
0121-0166	28480	5910-00-247-8600	0698-4190	28480	5905-00-126-1705
0122-0049	28480	5961-00-329-7671	0698-4521	28480	5905-00-489-2050
0140-0193	28480	5910-00-774-7319	0698-6299	28480	5905-00-477-9196
0160-0127	28480	5910-00-809-5484	0698-6302	28480	5905-00-477-9198
0160-0165	28480	5910-00-891-4208	0698-6315	28480	5905-00-477-9200
0160-0300	28480	5910-00-058-7916	0698-7233	28480	5905-00-160-5437
0160-0975	28480	5910-00-852-2661	0698-7532	28480	5905-00-138-3399
0160-2055	28480	5910-00-211-1611	0698-7533	28480	5905-00-138-3400
0160-2130	28480	5910-00-001-7244	0698-7915	28480	5905-00-001-8558
0160-2201	28480	5910-00-089-3496	0757-0158	28480	5905-00-430-6204
0160-2204	28480	5910-00-463-5949	0757-0198	28480	5905-00-830-6188
0160-2206	28480	5910-00-226-5187	0757-0274	28480	5905-00-858-9105
0160-2244	28480	5910-00-008-4451	0757-0276	28480	5905-00-493-0777
0160-2257	28480	5910-00-842-2302	0757-0279	28480	5905-00-221-8310
0160-2261	28480	5910-00-430-5750	0757-0280	28480	5905-00-853-8190
0160-2262	28480	5910-00-887-9754	0757-0290	28480	5905-00-858-8826
0160-2264	28480	5910-00-318-8758	0757-0316	28480	5905-00-981-7475
0160-2266	28480	5910-00-430-5754	0757-0317	28480	5905-00-244-7189
0160-2307	28480	5910-00-406-9675	0757-0344	28480	5905-00-269-2629
0160-3060	28480	5910-00-006-5732	0757-0346	28480	5905-00-998-1906
0160-3448	28480	5910-00-581-7084	0757-0394	28480	5905-00-412-4036
0180-0089	28480	5910-00-823-1548	0757-0397	28480	5905-00-232-3125
0180-0094	28480	5910-00-082-5119	0757-0400	28480	5905-00-998-1902
0180-0116	28480	5910-00-809-4701	0757-0401	28480	5905-00-981-7529
0180-0197	28480	5910-00-936-3862	0757-0403	28480	5905-00-412-4023
0180-0291	28480	5910-00-931-7055	0757-0417	28480	5905-00-858-9417
0180-1714	28480	5910-00-172-3138	0757-0418	28480	5905-00-412-4037
0180-1746	28480	5910-00-430-6036	0757-0419	28480	5905-00-891-4213
0180-1819	28480	5910-00-843-0354	0757-0420	28480	5905-00-493-5404
0340-0038	28480	5940-00-904-0300	0757-0422	28480	5905-00-728-9980
0340-0039	28480	5970-00-072-1625	0757-0438	28480	5905-00-929-2529
0360-0124	28480	5940-00-993-9338	0757-0439	28480	5905-00-990-0303
0370-0102	28480	5940-00-993-9338	0757-0440	28480	5905-00-858-6795
0370-0114	28480	5355-00-908-9418	0757-0442	28480	5905-00-998-1792
0684-2211	28480	5905-00-056-0406	0757-0444	28480	5905-00-858-9132
0698-0082	28480	5905-00-974-6075	0757-0449	28480	5905-00-891-2809
0698-0083	28480	5905-00-407-0052	0757-0458	28480	5905-00-494-4628
0698-3132	28480	5905-00-828-0388	0757-0460	28480	5905-00-858-8959
0698-3136	28480	5905-00-891-4247	0757-0463	28480	5905-00-764-2026
0698-3148	28480	5905-00-728-5057	0757-0465	28480	5905-00-904-4412
0698-3150	28480	5905-00-481-1357	0757-1094	28480	5905-00-917-0580
0698-3151	28480	5905-00-246-8634	0757-1100	28480	5905-00-917-0586
0698-3154	28480	5905-00-891-4215	08552-6044	28480	5950-00-431-3175
0698-3155	28480	5905-00-976-3418	08556-60001	28480	6625-00-346-8002
0698-3157	28480	5905-00-433-6904	08556-60007	28480	6625-00-346-8003

**PART NUMBER - NATIONAL STOCK NUMBER
CROSS REFERENCE INDEX**

PART NUMBER	FSCM	NATIONAL STOCK NUMBER	PART NUMBER	FSCM	NATIONAL STOCK NUMBER
08556-60009	28480	6625-00-346-8005	2140-0259	28480	6240-00-103-0058
08556-60012	28480	6625-00-346-8008	2190-0007	28480	5310-00-558-8023
08556-60026	28480	6625-00-346-8018	2420-0001	28480	5310-00-687-7337
08556-60027	28480	6625-00-346-8021	251-15-30-400	71785	5935-00-565-8380
08556-60028	28480	6625-00-346-8022	252-10-30-300	71785	5935-00-267-2973
08556-80001	28480	5950-00-328-2204	252-10-30-310	71785	5935-00-405-7718
08556-80003	28480	5950-00-328-2208	2950-0001	28480	5310-00-450-3324
1A-3303M	36196	5950-00-131-8317	30D107G025DD2-DSM	56289	5910-00-082-5119
102SR	08717	6210-00-978-6500	301-000-COGO-200J	72982	5910-00-945-1417
1025-20	99800	5950-00-059-5920	301-000-COKO-159C	72982	5910-00-063-0543
110488	28480	5985-00-563-9679	3100-3010	28480	5930-01-037-6644
11095A	28480	5935-00-454-9945	3100-3011	28480	5930-01-037-0970
116	08664	5120-00-198-5398	3100-3012	28480	5930-01-037-0971
1205-0011	28480	5999-00-789-3794	3101-0070	28480	5930-00-919-1755
1205-0037	28480	6625-00-403-6593	3101-1299	28480	5930-00-203-2080
1250-0053	28480	5935-00-081-3742	312001	75915	5920-00-280-8342
1251-0055	28480	5935-00-446-4112	5C13CS-CML	56289	5910-00-809-5484
1251-0055	28480	5935-00-623-7199	5000-0206	28480	5310-00-930-2722
1251-1631	28480	5935-00-163-3928	5040-0218	28480	6625-00-435-3153
1251-2034	28480	5935-00-267-2973	51-051-0000	98291	5935-00-539-1940
1410-0088	28480	3120-00-287-9026	52-053-0000	98291	5935-00-107-2601
1450-0371	28480	6210-00-834-2578	6008-32CN	91506	5999-00-333-9620
1510-0057	28480	5935-00-086-4692	9000	73734	5310-00-460-3057
1537-16	99800	5950-00-835-1513	9002	73734	5310-00-878-2193
1820-0054	28480	5962-00-138-5248	9100-0368	28480	5950-00-131-8317
1820-0055	28480	5962-00-493-5961	9100-1616	28480	5950-00-835-1513
1820-0076	28480	5962-00-420-1677	9100-1618	28480	5950-00-431-3196
1826-0013	28480	5962-00-247-9568	9100-1630	28480	5950-00-431-3198
1853-0001	28480	5961-00-962-5213	9100-1636	28480	5950-00-431-3199
1853-0007	28480	5961-00-765-6071	9100-1642	28480	5950-00-443-9513
1853-0012	28480	5961-00-941-2056	9100-2247	28480	5950-00-405-3735
1853-0020	28480	5961-00-904-2540	9100-2255	28480	5950-00-156-7270
1853-0034	28480	5961-00-987-4700	9140-0052	28480	5950-00-055-3592
1853-0050	28480	5961-00-138-7314	9140-0118	28480	5950-00-932-2727
1854-0019	28480	5961-00-919-4566	9140-0121	28480	5950-00-917-0654
1854-0039	28480	5961-00-985-9073	9140-0137	28480	5950-00-893-8650
1854-0247	28480	5961-00-464-4049	9140-0158	28480	5950-00-059-5920
1854-0404	28480	5961-00-408-9807	9140-0179	28480	5950-00-225-2177
1855-0372	28480	5961-00-332-0688	9140-0237	28480	5950-00-431-3216
1884-0073	28480	5961-00-654-3308			
1901-0025	28480	5961-00-978-7468			
1901-0040	28480	5961-00-965-5917			
1901-0050	28480	5961-00-914-7496			
1901-0376	28480	5961-00-790-7834			
1901-0518	28480	5961-00-430-6819			
1902-0184	28480	5961-00-842-9609			
1902-3104	28480	5961-00-995-2310			
1902-3139	28480	5961-00-845-6458			
1910-0016	28480	5961-00-752-5226			
192P27292-PTS	56289	5910-00-058-7916			
192P56392	56289	5910-00-891-4208			
2N2218	80131	5961-00-926-2533			
2N2904	80131	5961-00-941-2056			
2N3053	80131	5961-00-985-9073			
2N3251	80131	5961-00-765-6071			
2100-1757	28480	5905-00-407-0079			
2100-1762	28480	5905-00-229-1972			
2100-2487	28480	5905-00-332-0678			
2100-2488	28480	5905-00-407-0068			
2100-2528	28480	5905-00-138-5087			
2100-2531	28480	5905-00-403-4333			
2100-2574	28480	5905-00-139-2307			
2100-2632	28480	5905-00-476-5718			
2100-3066	28480	5905-00-333-1063			
2100-3107	28480	5905-00-333-1067			
2110-0269	28480	5999-00-333-9620			

NOTE

This manual has been corrected in accordance with the ERRATA which follows. Perform change(s) to this manual only if applicable, as determined by the equipment serial number, and in accordance with the Manual Changes table below.

This supplement contains important information for correcting manual errors and for adapting the manual to instruments containing improvements made after the printing of the manual.

To use this supplement:

Make all ERRATA corrections

Make all appropriate serial number related changes indicated in the tables below.

MANUAL IDENTIFICATION

Model Number: 8556A
 Date Printed: July 1971
 Part Number: 08556-90004

Serial Prefix or Number	Make Manual Changes
1124A00121 to 00130	1
1124A00131 to 00140	1,2
1126A	1,2,3
1143A00201 to 00585	1-4
1143A00586 to 00810	1-5
1250A	1-6

Serial Prefix or Number	Make Manual Changes
1404A thru 1404A02085	1-7
1404A02086 thru 1404A02235	1-8
1404A02236 thru 1404A prefix, 1634A. and 1907A	1-9

▶ NEW ITEM

ERRATA

Page 1-2, Paragraph 1-17:

▶ Change HP 11905A to HP 11095A.

Change HP 11048B 50 ohm Feed Thru Termination to HP 11048C.

Page 1-3, Table 1-1, FREQUENCY Resolution:

Change Bandwidth Selectivity: 60 dB/3 dB IF Bandwidth ratios to read: With 8552B IF Section:<11:1 for IF bandwidths from 30 Hz to 3 kHz, <20:1 for 10 kHz IF bandwidth. For 10 Hz bandwidth, 60 dB points are separated by less than 100 Hz.

▶ Page 1-4. Table 1-1, under "Dynamic Range":

Add a negative sign to the dBm and dBV values in the table:

Mode	1 kHz IF Bandwidth	10 Hz IF Bandwidth
dBm -50Ω	<- 122 dBm(180 nV)	<- 142 dBm(18 nV)
dBm - 600Ω	<- 130 dBm (250 nV)	<- 150 dBm (25 nV)
dBV	<- 132 dBV (250 nV)	<- 152 dBV(25 nV)
Linear	< 400 nV	< 40 nV

Page 14, Table 1-1, under "Accuracy":

Change "20 Hz to 10 kHz" to "30 Hz to 10 kHz."

NOTE

Manual change supplements are revised as often as necessary to keep manuals as current and accurate as possible. Hewlett-Packard recommends that you periodically request the latest edition of this supplement, Free copies are available from all HP offices. When requesting copies quote the manual identification information from your supplement, or the model number and print date from the title page of the manual.

ERRATA (Cont'd)

- ▶Page 1-6. Table 1-2. under "Zero Adjust"
Change ± 27 kHz range with 8552A" to " ± 40 kHz range with 8552A",

- ▶Page 1-9. Table 1-3:
Delete HP 5221 B and description from table.
Add:

HP 5381A

Electronic Counter
 Frequency Range : 10 Hz to 80 MHz
 Sensitivity: 25 mV
 Input Impedance: 1 Megohm
 Gate Time: 0.1, 1, and 10 sec.
 Resolution: 1 Hz
 Readout: 7 digit

- Page 2-1, Paragraph 2-9 and Page 3-1, Paragraph 3-11:
Add the following WARNING before the CAUTION:

WARNING

INPUT connector ground is isolated from cabinet ground. Any voltage present on cable shield will be present on connector shell (± 100 VDC maximum). If contacted, this voltage may cause personal injury.

- ▶Page 3-6, Figure 3-2. under "FOCUS AND ASTIGMATISM":
In step b, change -40dB to -50dB.
- Page 4-10, paragraph 4-18:
Replace steps 7 and 8 with attached steps 7 through 9.
- Page 6-4, Table 6-3:
Change to read, A6C1, C2 0160-3878 C:FXD CER .001 μ F;
Change to read, A6C22 0121-0479 C:VAR CER 1.7-11 pF.
- ▶Change HP Part Number and Mfr, Part Number of A6CR1 -A6CR4 to 5080-0272.
- Page 6-7, Table 6-3:
Change A8A1CR1-4 to 5080-0272 DIODE: SILICON MATCHED QUAD (NSR).
- ▶Change entry for A8A1R2 to: 0698-0085. R:FXD MET FLM 2.61K OHM 1% 1/8 W (FACTORY SELECT). 28480. 0698-0085. (Recommended replacement.)
- ▶Page 6-9, Table 6-3:
Add the following entry: 08556-40004, 1, STANDOFF EXTRUSION, 28480, 08556-40004.
- Page 6-10, Table 6-3:
Change Item 66 to 5020-8529 KNOB: PUSH.
- Page 8-2, Table 8-1, add the following:

Component	Location	Range of Values	Basis of Selection
A8A1R2	Service Sheet 7	2K to 3 K Ω	Sets Adj. range of A8A1R1. Select for 115 mVrms (into open ckt.) from J2, TRACKING GEN OUT, with A8A1R1 centered.

- ▶Page 8-25. Figure 8-25. Service Sheet 5:
Add reference designator L8 to the inductor adjacent to the crystal, Y1, L8 is across the crystal terminals.



ERRATA (Cont'd)

- ▶ Page 8-25, Figure 8-26, Service Sheet 5:
Change A6CR1-A6CR4 to 5080-0272 QUAD.
- Page 8-29, Figure 8-32, Service Sheet 7:
Change A8A1CR1-4 to 5080-0272 QUAD.
- ▶ Change the reference designator and value of ASA1R2 to R2*, 2610 ohms.

CHANGE 1

Page 1-6, Table 1-2,
Change to read: FREQUENCY CHARACTERISTICS
Zero Adjust: ± 30 kHz range with 8552A, ± 18 kHz range with 8552B.

Page 6-3, Table 6-3, Change as follows:
Delete: A1R2 0757-0465 R:FXD 100K OHM
A1R3 0698-3453 R:FXD 196K OHM
A1R4 0698-3161 R:FXD 38.3K OHM
Add: A1R2 0757-0461 R:FXD 68.1K OHM
A1R3 0757-0467 R:FXD 121K OHM
A1R4 0698-4486 R:FXD 24.9K OHM

Page 8-31, Service Sheet 9,
Change to read: THEORY OF OPERATION
Zero Adjustment Circuit
ZERO ADJ pot R6 is in a divider network from +20 V to ground. It can change the 47 MHz LO in the 8552B about 36 kHz, and in the 8552A about 80 kHz.

TROUBLESHOOTING

Zero Adjustment Circuit
The LO feed through signal on the CRT should shift as follows:
a. with 8552A IF Section, 80 ± 2 kHz.
b. with 8552B IF Section, 36 ± 2 kHz.

Page 8-33, Figure 8-38, Service Sheet 9:
Change A1R2 to 68.1 k ohms, A1R3 to 121 k ohms, and A1R4 to 24.9 k ohms.

CHANGE 2

Page 6-3, Table 6-3, Change as follows:
Delete: A1R1 0757-0274 R:FXD 1.21K OHM
Add: A1R1 0757-0424 R:FXD 1.1 K OHM
Page 6-9, Table 6-3, Change as follows:
Add: R7 0698-3160 R:FXD MET FLM 31.6K OHM 1% 1/8W

Page 8-2, Table 8-1, Change as follows:
Delete: A1R1 (entire file)
Add:

Component	Location	Range of Values	Basis of Selection
A1R7	Service Sheet 9	19.6 k to 100 k ohms	Sets upper limit of 300 kHz ADJ. Select for +15.65V \pm 0.05V at test point A (A11XA7 pin 5) with analyzer set as follows: RANGE0-300 kHz FREQUENCY300 kHz FINE TUNECentered 300 kHz ADJ.....full cw

Page 8-33, Figure 8-38, Service Sheet 9:
Change A1R1 to 1.1 k ohms and remove asterisk (*). Add R7* 31.6 k ohms across R3 (from 978 wire to ground).



CHANGE 3

Page 6-4, Table 6-3, Change as follows:

Delete: A5R11 0698-3150 R:FXD 2.37K OHM
 A5R13 0698-3162 R:FXD 46.4K OHM
 A5R14,16 0698-3455 R:FXD 261K OHM
 Add: A5R11 0698-3154 R:FXD 4.22K OHM
 A5R13 0757-0463 R:FXD 82.5K OHM
 A5R14,16 0698-3454 R:FXD 215K OHM
 A5R21 0698-3158 R:FXD MET FLM 23.7K OHM 1% 1/8W

Page 6-6, Table 6-3, Change as follows:

Delete: A8Q1 1854-0404
 Add: A8Q1 1854-0053

Page 6-8, Table 6-3, Change as follows:

Delete: A10R2 0757-0465 R:FXD 100K OHM
 Add: A10R2 0757-0458 R:FXD 51.1K OHM
 A10R5, R6 0757-0280 R: FXD 1.0K OHM
 A10C7 0180-0116 C:FXD 6.8 UF
 A10CR7 1884-0073 THYRISTOR:SCR
 A10CR8 1902-0184 DIODE:BREAKDOWN 16.2V

Page 6-9, Table 6-3, Change as follows:

Add: E1 1250-0053 CONNECTOR: RF BNC CAP AND CHAIN

Page 8-23, Figure 8-23, Service Sheet 4:

Replace appropriate portions of schematic with attached partial schematics.

Page 8-29, Figure 8-32, Service Sheet 7:

Change A8Q1 to 1854-0053.

Page 8-39, Service Sheet 12:

► Replace Figure 8-46 with Figure 8-46 shown in this supplement.

Replace appropriate portion of Figure 8-48 with partial schematic shown in this supplement.

CHANGE 4

Page 6-4, Table 6-3, Change as follows:

Delete: A5K2 0490-0965 RELAY:REED 12 VDC 0.5A
 Add: A5K2 0490-1014 RELAY:REED 12 VDC 0.5A

Page 6-10, Table 6-3, Change to read:

33 08556-40002 WINDOW:STATIONARY-BLACK
 34 0855640003 WINDOW:SLIDING-BLACK
 40 08556-20003 EXTRUSION:ENGRAVED-LIGHT GRAY
 61 08556-00009 PLATE:CONNECTOR-BLACK
 62 08556-00002 PANEL:FRONT-LIGHT GRAY

Add the following:

33 08556-40005 WINDOW:STATIONARY-OLIVE BLACK
 34 0855640006 WINDOW:SLIDING-OLIVE BLACK
 40 08556-20019 EXTRUSION:ENGRAVED-MINT GRAY
 61 08556-00032 PLATE:CONNECTOR-OLIVE BLACK
 62 08556-00023 PANEL:FRONT-MINT GRAY

CHANGE 5

Page 6-7, Table 6-3:

Change: A8A1Q3 and Q4 to 1853-0007.

Page 8-29, Figure 8-32, Service Sheet 7:

Change: A8A1Q3 and Q4 to 1853-0007.



CHANGE 6

Page 6-3, Table 6-3:

Add: A2R24 0698-3444 R:FXD MET FLM 316 OHM 1% 1/8W.

Pages 8-32 and 8-33. Service Sheet 9:

In the table under "Ramp Control Circuits" in the text, change the voltmeter readings for 50 Hz to " -12.25 ± 0.14 mV." and for 20 Hz to " -4.72 ± 0.07 mV."

► Replace Figure 8-36 with Figure 8-36 shown in this supplement.

On Figure 8-38, replace the appropriate portion of the schematic with the attached partial schematic.

CHANGE 7

Page 6-3, Table 6-3:

Change A5C5 to 0160-4178, C:FXD ELECT 3.0UF +50 -10% 200 VDCW, 28489, 0160-4178.

Page 8-23, Figure 8-23 (Service Sheet 4):

Change A5C5 to 3.0 μ F.

CHANGE 8

Page 6-9, Table 6-3:

Change HP Part Number 08556-00013 to 08556-00043.

Change HP Part Number 08556-00014 to 08556-00044.

Change HP Part Number 08556-00015 to 08556-00045.

Change HP Part Number 08556-00016 to 08556-00046.

CHANGE 9

Page 6-4, Table 6-3:

Change A6C22 HP Part Number to 0121-0493, C: VAR AIR 1.7-11.0 PF 250VDC.



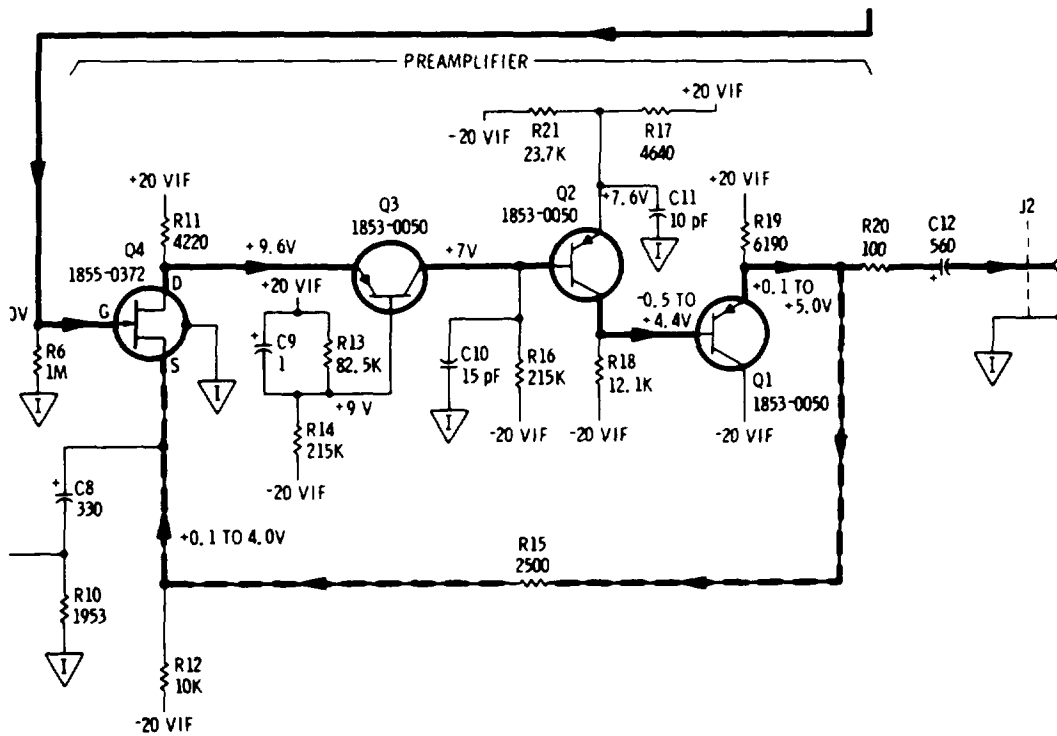
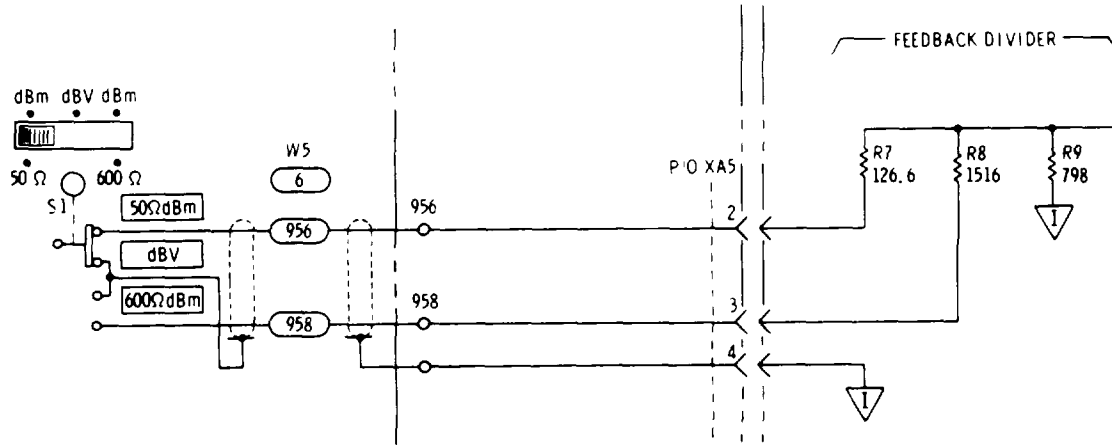

Figure 8-23. Pre-Attenuator and Preamplifier: A3, A5 and A11 (Part of CHANGE 3)



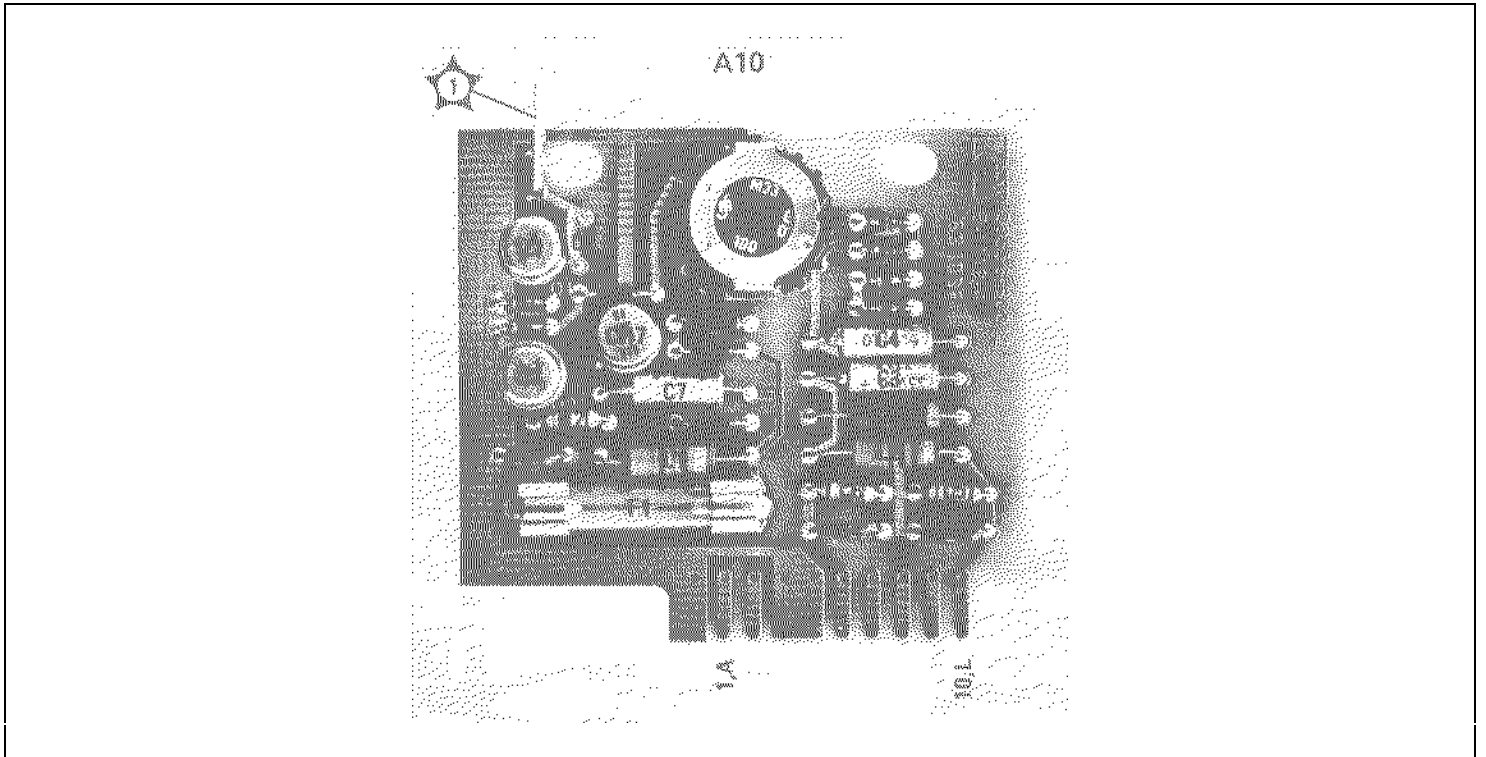

Figure 8-46. Power Supply Assembly A10 Component Locations (Part of CHANGE 3)

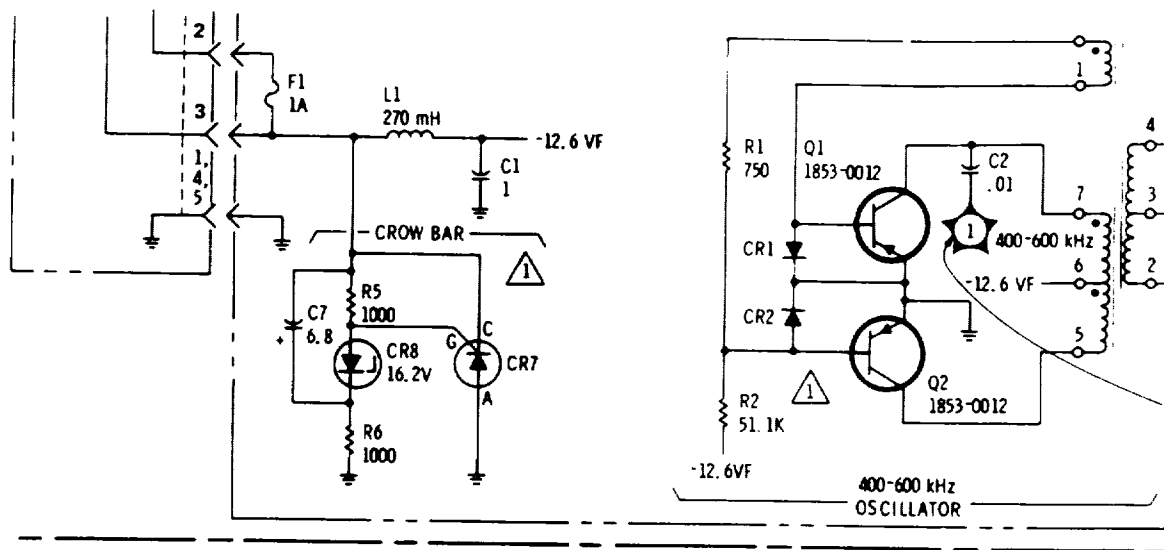

Figure 8-48. Power Supply and Voltage Distribution: A 10 and A 11 (Part of CHANGE 3)



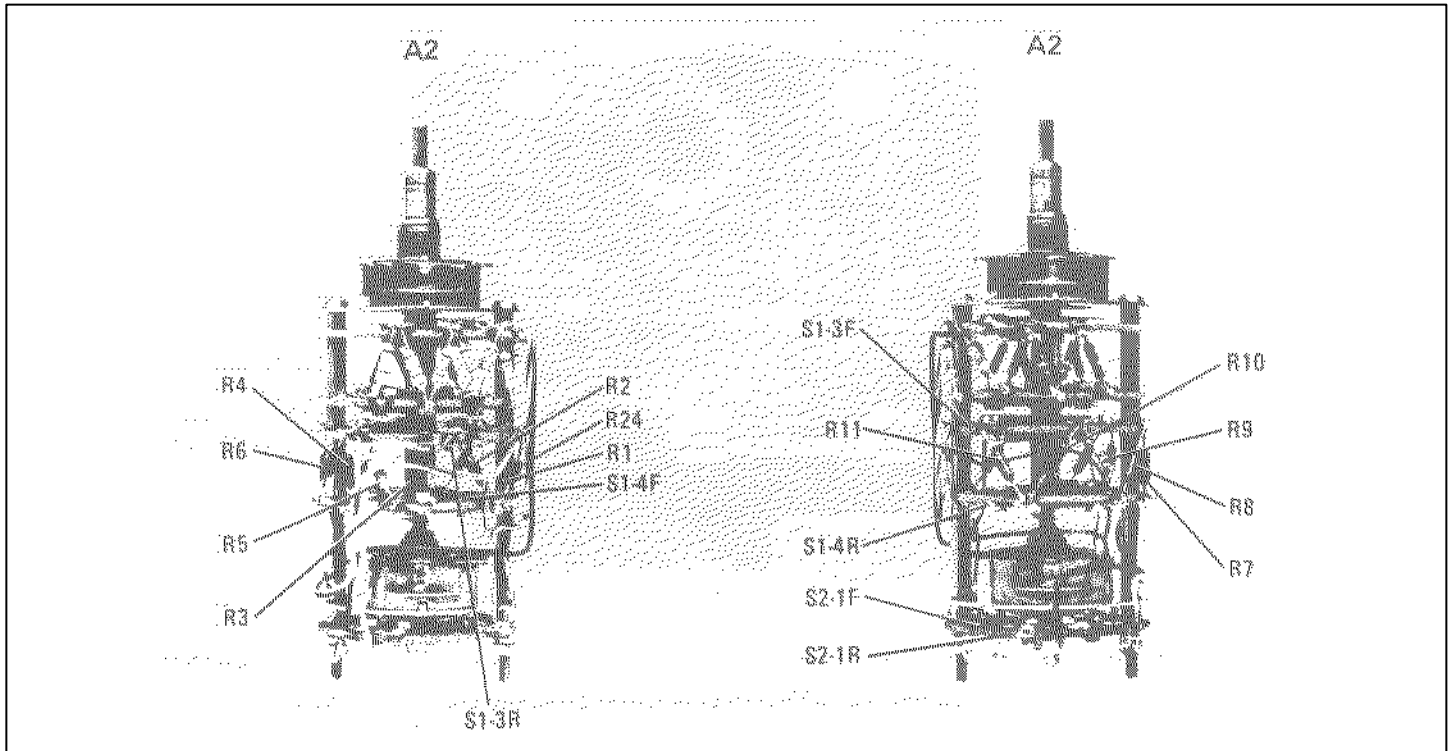

Figure 8-36. Scan Width Switch Assembly-A2 Component Locations (Part of CHANGE 6)

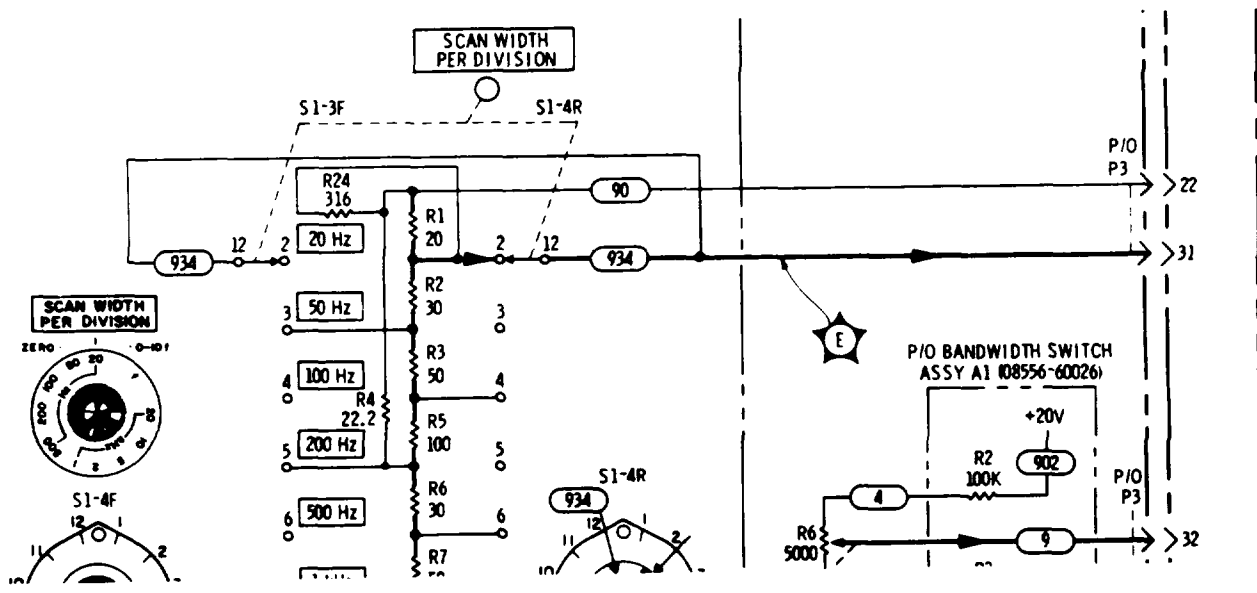

Figure 8-38. Frequency Control Circuits: A1, A2 and A7 (Part of CHANGE 6)



PERFORMANCE TESTS

4-18. FREQUENCY RESPONSE

7. Tune FREQUENCY Control to frequencies noted below. At each frequency, re-adjust TRACKING GEN LEVEL for a 1.000 volt reading on first Digital Voltmeter, then note reading on second Digital Voltmeter (don't re-adjust LINEAR SENSITIVITY).

Frequency	Reading
1 kHz	_____ mV
3 kHz	_____ mV
5 kHz	_____ mV
10 kHz	_____ mV
20 kHz	_____ mV
30 kHz	_____ mV

Difference between the maximum and minimum readings shall not exceed 32.2 mV.

_____ 32.2 mV

8. Set RANGE to 0-300 kHz and tune FREQUENCY to 5 kHz. Again, re-adjust TRACKING GEN LEVEL for a 1.000 volt reading on first Digital Voltmeter. Adjust LINEAR SENSITIVITY for a 700 mV reference on second Digital Voltmeter.
9. Tune FREQUENCY control to frequencies noted below. At each frequency, re-adjust TRACKING GEN LEVEL for a 1.000 volt reading on first Digital Voltmeter, then note reading on second Digital Voltmeter (don't re-adjust LINEAR SENSITIVITY).

Frequency	Reading
50 kHz	_____ mV
100 kHz	_____ mV
150 kHz	_____ mV
200 kHz	_____ mV
250 kHz	_____ mV
300 kHz	_____ mV

Difference between the maximum and minimum readings shall not exceed 32.2 mV.

_____ 32.2 mV



RECOMMENDED CHANGES TO EQUIPMENT TECHNICAL MANUALS



SOMETHING WRONG WITH THIS MANUAL?

THEN...JOT DOWN THE DOPE ABOUT IT ON THIS FORM, TEAR IT OUT, FOLD IT AND DROP IT IN THE MAIL!

FROM: (YOUR UNIT'S COMPLETE ADDRESS)

Commander
Stateside Army Depot
ATTN: AMSTA-US
Stateside, N.J. 07703

DATE 10 July 1975

PUBLICATION NUMBER

TM 11-5840-340-12

DATE

23 Jan 74

TITLE

Radar Set AN/APC-76

BE EXACT...PIN-POINT WHERE IT IS

IN THIS SPACE TELL WHAT IS WRONG AND WHAT SHOULD BE DONE ABOUT IT:

PAGE NO.	PARA-GRAPH	FIGURE NO.	TABLE NO.
2-25	2-28		
3-10	3-3		3-1
5-6	5-8		
		FO3	

Recommend that the installation antenna alignment procedure be changed through to specify a 2° IFF antenna lag rather than 1°.

REASON: Experience has shown that with only a 1° lag, the antenna servo system is too sensitive to wind gusting in excess of 25 knots, and has a tendency to rapidly accelerate and decelerate as it hunts, causing strain to the drive train. Hunting is minimized by adjusting the lag to 2° without degradation of operation.

Item 5, Functions column. Change "2 db" to "3db."

REASON: The adjustment procedure for the TRANS POWER FAULT indicator calls for a 3 db (500 watts) adjustment to light the TRANS POWER FAULT indicator.

Add new step f.1 to read, "Replace cover plate removed in step e.1, above."

REASON: To replace the cover plate.

Zone C 3. On J1-2, change "+24 VDC to "+5 VDC."

REASON: This is the output line of the 5 VDC power supply. + 24 VDC is the input voltage.

TEAR ALONG DOTTED LINE

TYPED NAME, GRADE OR TITLE, AND TELEPHONE NUMBER

SSG I. M. DeSpirito 999-1776

SIGN HERE:

SSG I. M. DeSpirito

DA FORM 2028-2 (TEST) 1 AUG 74

P.S.--IF YOUR OUTFIT WANTS TO KNOW ABOUT YOUR MANUAL "FIND" MAKE A CARBON COPY OF THIS AND GIVE IT TO YOUR HEADQUARTERS.

HISA 1686-75

RECOMMENDED CHANGES TO EQUIPMENT TECHNICAL PUBLICATIONS



THEN... JOT DOWN THE DOPE ABOUT IT ON THIS FORM, CAREFULLY TEAR IT OUT, FOLD IT AND DROP IT IN THE MAIL!

SOMETHING WRONG WITH THIS PUBLICATION?

FROM: (PRINT YOUR UNIT'S COMPLETE ADDRESS)

DATE SENT

PUBLICATION NUMBER

TM 11-6625-2781-14&P-5

PUBLICATION DATE

27 Apr 83

PUBLICATION TITLE

PL-1387/U (HP-8556A)

BE EXACT... PIN-POINT WHERE IT IS

PAGE NO

PARA-GRAPH

FIGURE NO.

TABLE NO

IN THIS SPACE TELL WHAT IS WRONG AND WHAT SHOULD BE DONE ABOUT IT:

TEAR ALONG PERFORATION LINE

PRINTED NAME, GRADE OR TITLE, AND TELEPHONE NUMBER

SIGN HERE:

DA FORM 2028-2
1 JUL 79

PREVIOUS EDITIONS ARE OBSOLETE.

P.S.-IF YOUR OUTFIT WANTS TO KNOW ABOUT YOUR RECOMMENDATION MAKE A CARBON COPY OF THIS AND GIVE IT TO YOUR HEADQUARTERS.

FILL IN YOUR
UNIT'S ADDRESS

FOLD BACK

DEPARTMENT OF THE ARMY

OFFICIAL BUSINESS
PENALTY FOR PRIVATE USE \$300

POSTAGE AND FEES PAID
DEPARTMENT OF THE ARMY
DOD 314



TEAR ALONG
DASHED LINE

By Order of the Secretary of the Army:

Official:

E. C. MEYER
General, United States Army
Chief of Staff

ROBERT M. JOYCE
Major General, United States Army
The Adjutant General

Distribution:

To be distributed in accordance with DA Form 12-34B, requirements for TMDE/Calibration Maintenance Manuals.

